

GB51

PNEUMATIC INSTALLATION TOOL

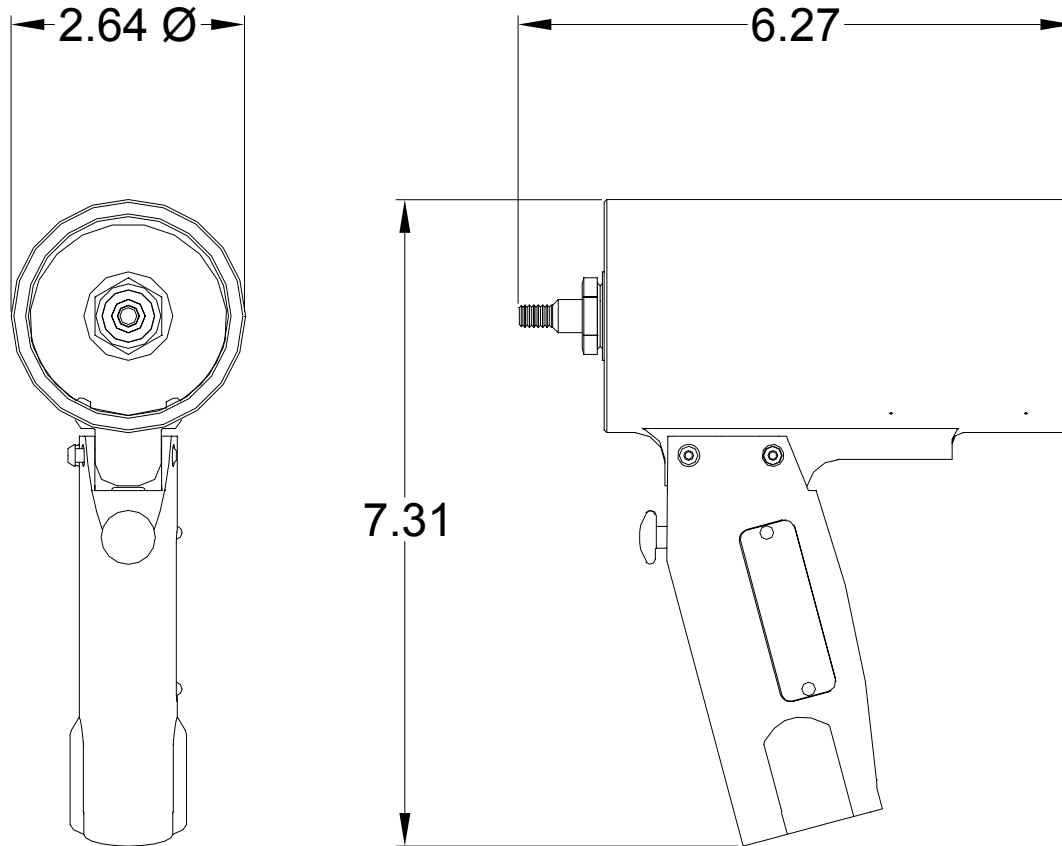

DESCRIPTION

The GB51 pneumatic riveter is designed specifically for the most efficient installation of a wide range of blind rivets. It will install aluminum rivets through 3/16" diameter, and through 1/8" diameter rivets in any material. It weighs only 2 1/2 lbs. and can be operated in any position with one hand.

The GB51 Riveter is 7" high, has a .740 stroke and generates a minimum of 1000 lbs. of pull at 90 psi. It operates from 80 to 110 psi of air pressure at the tool.

NOSE ASSEMBLIES ARE NOT FURNISHED WITH THIS TOOL AND MUST BE PURCHASED SEPARATELY.

GAGE BILT
MADE IN U.S.A.

GAGE BILT PRODUCTS CORP.

44766 Centre Court

(586) 226-1500

Clinton Twp. MI 48038

(586) 226-1505 Fax

e-mail: solutions@gagebilt.com / www.gagebilt.com

GB51 SELECTION CHART



FASTENER	DIA.	STRAIGHT	RIGHT ANGLE ¹	OFFSET
NUT PLATE RIVETS MS20600 SERIES CCR244/264/274 MS/9SP/PT BACR15CC/CF/DA/DR	3/32 1/8 5/32 ₃ 3/16 ₃	3C-715B-43 4C-715B-43 5C-715B-43 6C-715B-43	3C-715-54RA 4C-715-54RA 5C-715-54RA 6C-715-54RA	3C-715-40OS 4C-715-40OS 5C-715-40OS 6C-715-40OS
"A" CODE NAS1398A, NAS1399A NAS1740A, NAS1739A	3/32 1/8 5/32 ₃ 3/16 ₅	3A-715B-43 4A-715B-43 5A-715B-43 6A-715B-43	3A-715-54RA 4A-715-54RA 5A-715-54RA 6A-715-54RA	3A-715-40OS 4A-715-40OS 5A-715-40OS 6A-715-40OS
SINGLE ACTION BLIND RIVET NAS1919S & U NAS1921S & U	1/8 5/32 ₃ 3/16 ₃	SMLS04-715B-43 SMLS05-715B-43 SMLS06-715B-43	SMLS04-715-54RA SMLS05-715-54RA SMLS06-715-54RA	SMLS04-715A-40OS SMLS05-715A-40OS SMLS06-715A-40OS
BACR15FR/FP, BACR15GF/GK, NAS1919 & NAS1921 "U" TYPE BLIND RIVET WITH DRIVE WASHER NAS9301-9312	1/8 5/32 ₄	456MAX-715-43 ₂	456MAX-715A-54RA ₂	456MAX-715A-40OS ₂
N, Q & E POP®, CLOSED END AVEX® & COMMERCIAL RIVETS	3/32 1/8 5/32 ₃ 3/16 ₃	3N-715E-43 4N-715E-43 5N-715E-43 6N-715E-43	3N-715-54RA 4N-715-54RA 5N-715-54RA 6N-715-54RA	3N-715-40OS 4N-715-40OS 5N-715-40OS 6N-715-40OS

THE GAGE BILT GB51 TOOL IS APPROVED TO INSTALL THE ABOVE FASTENERS.

1) RIGHT ANGLE NOSE ASSEMBLYS MAY REQUIRE MORE THAN ONE PULL.
2) INSTALLS 1/8 & 5/32 DIAMETERS.
3) ALUMINUM ONLY.
4) ALUMINUM SLEEVE STEEL STEM REQUIRES 100 P.S.I.
5) SELF-PLUGGING ALUMINUM ONLY
*ALL COUNTERSUNK 'C' NOSE ASSEMBLIES MAY BE USED TO INTSALL BOTH UNIVERSAL & COUNTERSUNK HEAD RIVETS

NOTE: THE LAST 2 DIGITS OF THE NOSE ASSEMBLY REPRESENTS THE LENGTH THE NOSE
EXTENDS FROM THE TOOL I.E. -20 = 2.0 INCHES