

GB703 SERIES INSTALLATION TOOLS

GB703

Stroke - .780"
 Hand held weight - 4.50 lbs.
 Entire tool weight - 4.50 lbs
 Pull load - 2,200

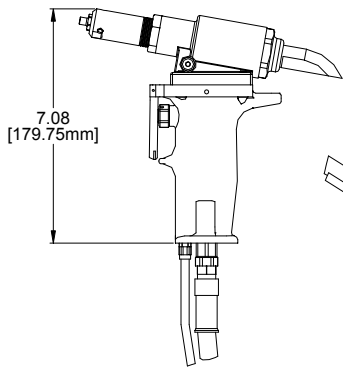
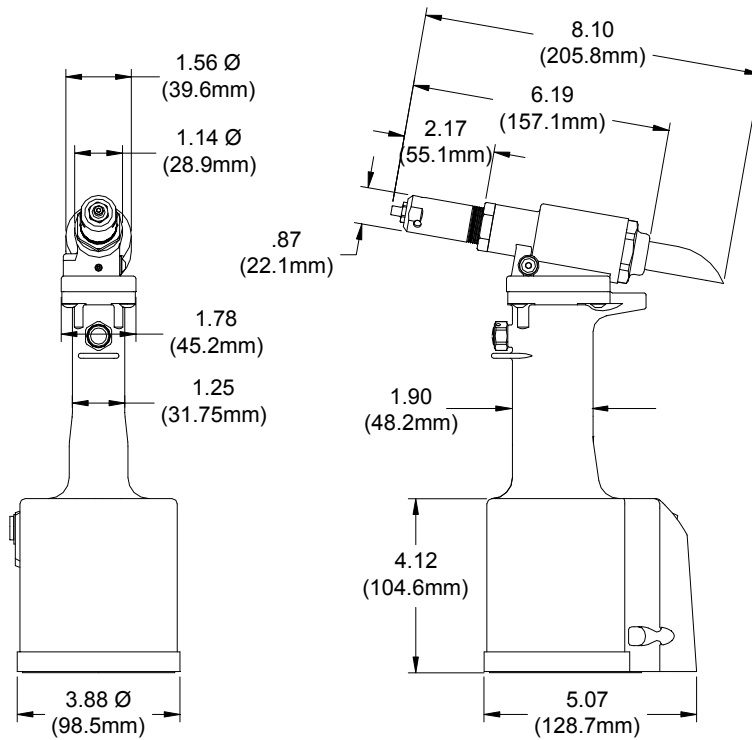

GB703SH

Stroke - .800"
 Hand held weight - 2.00 lbs.
 Entire tool weight - 7.25 lbs
 Pull load - 2,200

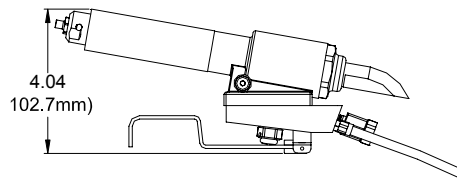
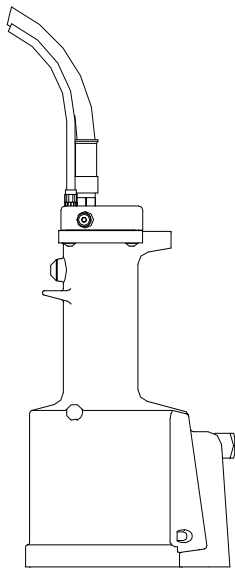

GB703SR

Stroke - .780"
 Hand held weight - 1.50 lbs.
 Entire tool weight - 4.50 lbs
 Pull load - 2,200

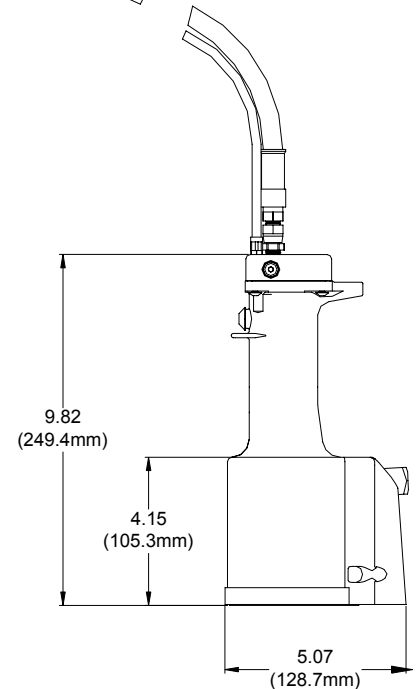

GAGE BILT

MADE IN U.S.A.

GAGE BILT Inc.

44766 Centre Court (586) 226-1500
 Clinton Twp. MI 48038 (586) 226-1505 Fax
 e-mail: solutions@gagebilt.com / www.gagebilt.com

DESCRIPTION

The GB703 series are pneumatic-hydraulic tools designed specifically for the efficient installation of a wide range of blind rivets. They can be operated in any position with one hand. They have a rated pull load of 2200 pounds with 90 psi air pressure at the air inlet.

The GB703SH and GB703SR riveters offer a unique "split" system providing the operator with an ergonomic tool with reduced hand held weight, as shown below.

The GB703 series riveters operate on a wide range of air pressure, with 90 to 100 psi providing the maximum efficiency. At 90 psi air pressure, the GB703 series does not exceed 85 db (A) and consumes 3 cfm at 20 cycles a minute.

Unless ordered rivet specific (I.E. GB703/4N), the GB703 series riveters are furnished with nose assembly 6N-703-18 and spare nose tip 10202 and follower 40307 to convert to 4N-703-18 nose assembly. All other nose tips must be ordered separately. When ordering tool rivet specific, contact Gage Bilt for more information.

"VT" riveters are not furnished with the nose assemblies above and must be ordered for your specific rivet.

OPTIONS

The GB703 series riveters may be ordered with a vacuum system. Gage Bilt offers two varieties (see below)

Order GB703 series riveters rivet specific by adding the appropriate suffix (see selection chart).



GB703 SERIES SELECTION CHART



RIVET	DIA.	NOSE ASSEMBLY	NOSE TIP 1	JAW	FOLLOWER	DESIGNATION
AVEX® (1624 PROTRUDING HEAD)	3/16	AV6-743A-24 2	-	-	-	AV6
AVEX (1624 COUNTERSUNK HEAD)	3/16	6C-743A-24 2	-	-	-	6C
KLAMP-TITE® (STRUCTURAL) RIVET	3/16	6KT-703-18 1	10263	30617	40605	6KT
	1/4	8KT-743A-24 2	-	-	-	8KT
MACHINE SCREW RIVET	5MM	M5SM-703-18 1	10332	30617	40605	5MM
MONOBOLT® RIVET	3/16	MB06-734A-20 2,5	-	-	-	MB06
	1/4 3	MB08-734A-20 2,5	-	-	-	MB08
NUTPLATE RIVET CCR244/264/274 BACR15DR MS20600	3/32	3NP-703-18 1	10231	30617	40307	3NP
	1/8	5N-703-18 1	10203	30617	40605	5N
OPEN END NAIL RIVET	3/32	3N-703-18 1	10201	30617	40307	3N
	1/8	4N-703-18 1	10202	30617	40307	4N
	5/32	5N-703-18 1	10203	30617	40605	5N
	3/16	6N-703-18 1	10204	30617	40605	6N
	1/4 3	8N-743A-24 2	-	-	-	8N
CLOSED END NAIL RIVET (ALUMINUM MANDREL)	3/32	3CEA-703-18 1	13470	30617	40307	3CEA
	1/8	4CEA-703-18 1	13471	30617	40307	4CEA
	5/32	5CEA-703-18 1	13472	30617	40605	5CEA
	3/16	6CEA-703-18 1	13473	30617	40605	6CEA
CLOSED END NAIL RIVET (STEEL MANDREL)	3/32	3CES-703-18 1	13474	30617	40307	3CES
	1/8	4CES-703-18 1	13475	30617	40307	4CES
	5/32	5CES-703-18 1	13476	30617	40605	5CES
	3/16	6CES-703-18 1	13477	30617	40605	6CES
	1/4 3	8CES-743A-24 2	-	-	-	8CES
PLASTIC SPLIT RIVET	3/32	3P-703-18 1	10247-1	30617	40307	3P
	1/8	4P-703-18 1	10202-4	30617	40307	4P
	5/32	5P-703-18 1	10203-2	30617	40605	5P
	3/16	6P-703-18 1	10167	30617	40605	6P
	1/4	8P-743A-24 2	-	-	-	8P
T RIVET®	3/16	6T-703-18 1	10209	30617	40605	6T
	1/4 3	8T-743A-24 2	-	-	-	8T
TLR® RIVET	1/4	8TLR-743A-24 2	-	-	-	8TLR
COUNTERSUNK HEAD SERRATED STEM STRUCTURAL RIVET	3/16	C6-734A-20 2,5	-	-	-	C6
	1/4 4	C8-734A-20 2,5	-	-	-	C8
PROTRUDING HEAD SERRATED STEM STRUCTURAL RIVET	3/16	PH6-734A-20 2,5	-	-	-	PH6
	1/4 4	PH8-734A-20 2,3,5	-	-	-	PH8

AVEX®, KLAMP-TITE®, TLR®, AND MONOBOLT® ARE REGISTERED TRADEMARKS OF AVDEL UK LIMITED. T RIVET® IS A REGISTERED TRADEMARK OF CHERRY AEROSPACE FASTENERS.

1) YOU CAN CHANGE THE 703-18 NOSE ASSEMBLY (INCLUDED WITH TOOL) TO INSTALL OTHER FASTENERS BY PURCHASING NOSE TIP SHOWN AND USING APPROPRIATE FOLLOWER SHOWN.

2) NOSE ASSEMBLIES WITH A 743A-24 AND 734A-20 DESIGNATION, I.E. 8N-743A-24, MUST BE ORDERED AS COMPLETE NOSE ASSEMBLY.
3) ALUMINUM RIVET STEEL MANDREL ONLY (100 PSI REQUIRED FOR ALL 1/4" STEEL RIVETS).

4) 1/4" ALUMINUM ONLY.

5) NOSE ASSEMBLIES WITH A 734A DESIGNATION, I.E. PH6-734A-20, ARE FOR SERRATED STEM RIVETS ONLY. IF YOU ARE PULLING BOTH SMOOTH AND SERRATED STEM RIVETS YOU MUST ORDER THE NOSE ASSEMBLY WITH A 743A DESIGNATION, I.E. MGL06-743A-24.

NOTE: THE LAST 2 DIGITS OF THE NOSE ASSEMBLY REPRESENTS THE LENGTH THE NOSE EXTENDS FROM THE TOOL. I.E. -20 = 2.0 INCHES

REV. 2/13

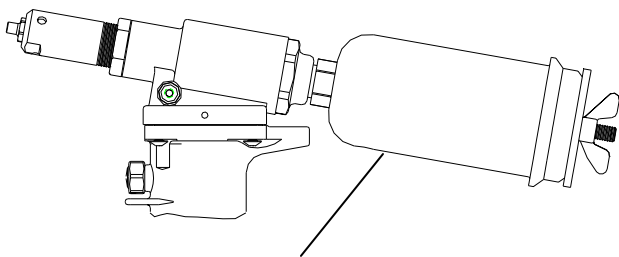

"V" DESIGNATION = PINTAIL COLLECTOR BOTTLE

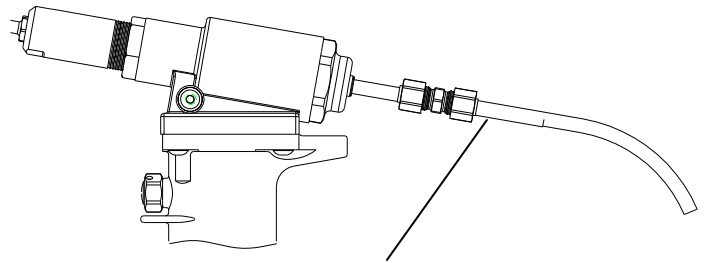

"VT" DESIGNATION = PINTAIL EVACUATION TUBE
(TOOL MUST BE ORDERED FOR YOUR SPECIFIC RIVET. CONTACT GAGE BILT INC. FOR SPECIFIC APPLICATIONS.)

HOW TO ORDER GB703 SERIES TOOLS

