

GB731OS

INSTALLATION TOOL

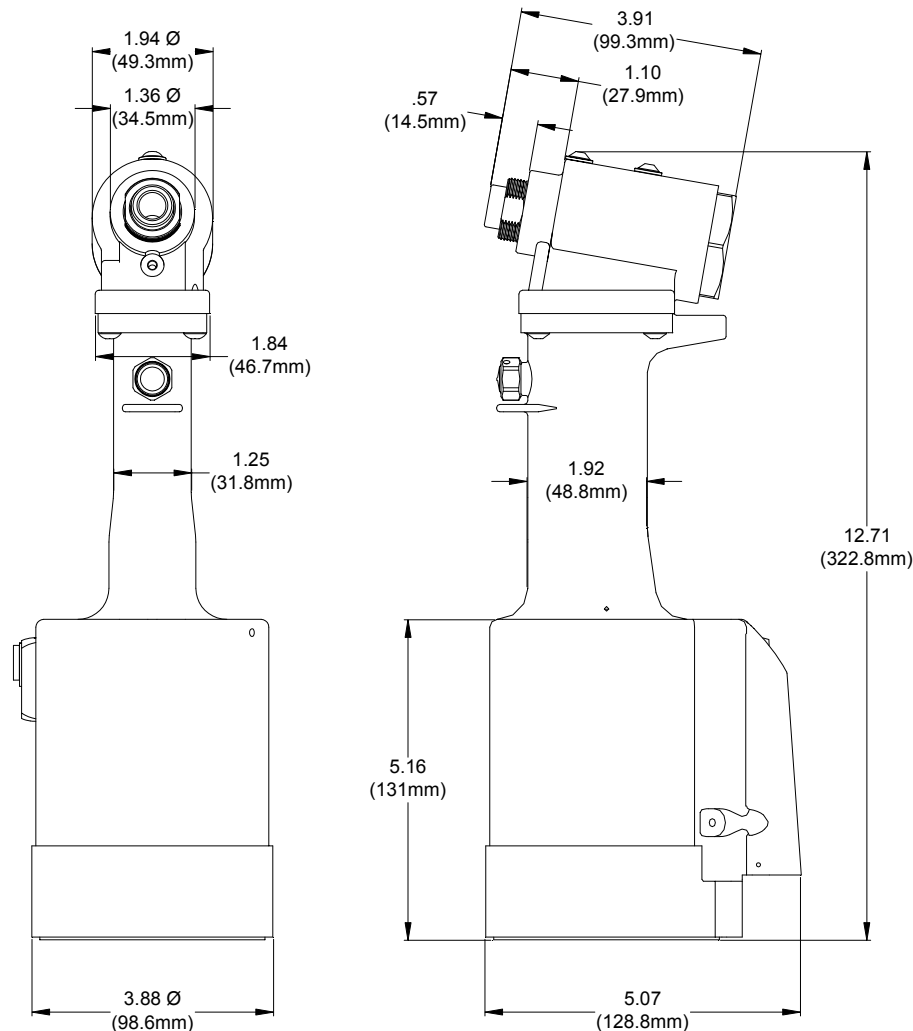

DESCRIPTION

The GB731OS is a pneumatic-hydraulic tool designed specifically for the efficient installation of a wide range of blind rivets and lockbolts. It weighs just under 5.7 lbs. and can be operated in any position with one hand. It has a .600 rivet setting stroke and a rated pull load of 4800 pounds on 90 psi air pressure at the air inlet.

The GB731OS riveter operates on a wide range of air pressure, with 90 to 100 psi providing the maximum efficiency. At 90 lbs. air pressure, the GB731OS does not exceed 85 db (A) and consumes 3.9 cfm at 20 cycles per minute.

The air inlet is provided with 1/4-18 female pipe threads for accepting the user's air hose fitting.

NOSE ASSEMBLIES ARE NOT FURNISHED WITH THIS RIVETER AND MUST BE ORDERED SEPARATELY.

GAGE BILT

MADE IN U.S.A.

GAGE BILT Inc.

44766 Centre Court (586) 226-1500
Clinton Twp. MI 48038 (586) 226-1505 Fax
e-mail:solutions@gagebilt.com / www.gagebilt.com

GB731OS SELECTION CHART



FASTENER	DIA.	STANDARD	STRADDLE NOSE (1)	LONG
LOCKBOLT, NAS SHEAR PULL TYPE, NAS TENSION PULL TYPE, NASS = SHEAR & GP NAST = TENSION	5/32" 3/16" 1/4"	NAST05-204C-25OS NASS05-204C-25OS NAS06-204C-25OS NAS08-204C-25OS	NAST05-204C-30OS NASS05-204C-30OS NAS06-204C-30OS NAS08-204C-30OS	NAST05-204C-34OS NASS05-204C-34OS NAS06-204C-34OS NAS08-204C-34OS
MGP®	4mm 5mm	MGP4-204C-25OS MGP5-204C-25OS	MGP4-204C-30OS MGP5-204C-30OS	MGP4-204C-34OS MGP5-204C-34OS
LGP® Lightw eight Groove Proportion LOCKBOLT	5/32" 3/16" 1/4"	LGP05-204C-25OS LGP06-204C-25OS LGP08-204C-25OS	LGP05-204C-30OS LGP06-204C-30OS LGP08-204C-30OS	LGP05-204C-34OS LGP06-204C-34OS LGP08-204C-34OS
MLGP®	4mm 5mm	MLGP4-204C-25OS MLGP5-204C-25OS	MLGP4-204C-30OS MLGP5-204C-30OS	MLGP4-204C-34OS MLGP5-204C-34OS
BLIND RIVET (SINGLE ACTION) WITH OR W/OUT DRIVE WASHER NAS1900 S & U SERIES	1/8" 5/32" 3/16" 1/4"	SMLS04-204D-27OS SMLS05-204D-27OS SMLS06-204D-27OS SMLS08-204D-27OS		SMLS04-204D-37OS SMLS05-204D-37OS SMLS06-204D-37OS SMLS08-204D-37OS
BLIND BOLT (SINGLE ACTION) WITH OR W/OUT DRIVE WASHER MS90353S & U / MS90354S & U MS21140S & U / MS21141S & U CR7000 SERIES, BACB30YY, YU, & YT	5/32" 3/16" 1/4"	SB05-204D-27OS SB06-204D-27OS SB08-204D-27OS		SB05-204D-37OS SB06-204D-37OS SB08-204D-37OS
EN6122 & UAB130-EU EN6127 & UAB6127-EU EN6128 & UAB100-EU EN6129 & UABP-EU	3/16" 1/4"	UAB06-204D-27OS UAB08-204D-27OS		UAB06-204D-37OS UAB08-204D-37OS
BACR15FR/FP, BACR15GF/GK, NAS1900 S & U SERIES BLIND RIVET WITH DRIVE WASHER NAS9301-9312	1/4"	08MAX-204D-27OS		08MAX-204D-37OS
"A" CODE NAS1398A & NAS1399A	1/8" 5/32" 3/16" 1/4"	4A-204D-27OS 5A-204D-27OS 6A-204D-27OS SMLS08-204D-27OS		4A-204D-37OS 5A-204D-37OS 6A-204D-37OS SMLS08-204D-37OS
ASP® 2, ASP PF, ASP 4 FF, ASP 2 F, ASP 2 LC	13/64" 17/64" 21/64"	ASP06-204D-27OS ASP08-204D-27OS ASP10-204D-27OS		ASP06-204D-37OS ASP08-204D-37OS ASP10-204D-37OS
NAS1719, NAS1720, NAS1721 & MBC	1/8" 5/32" 3/16"	MBC04-204D-27OS MBC05-204D-27OS MBC06-204D-27OS		MBC04-204D-37OS MBC05-204D-37OS MBC06-204D-37OS
GROUND STUD, BACS53B	13/64" 17/64"	GS8-204D-32OS GS10-204D-32OS		GS8-204D-42OS GS10-204D-42OS

MGP®, LGP®, MLGP®, AND ASP® ARE REGISTERED TRADEMARKS OF ALCOA INC.

GAGE BILT CERTIFIES THE GB731OS WILL INSTALL THE ABOVE FASTENERS

1) -30 STRADDLE NOSES ARE DESIGNED TO REACH OVER THE COLLAR.

NOTE: THE LAST 2 DIGITS OF THE NOSE ASSEMBLY REPRESENTS THE LENGTH
THE NOSE ASSEMBLY EXTENDS FROM THE TOOL. (I.e. -27 = 2.7 inches)

10/11

**GAGE BILT ALSO SUPPLIES PIN & COLLAR SWAGE INSPECTION
GAGES TO CERTIFY CORRECT SWAGE INSTALLATION.**

