

GBP500 SERIES GBP500A SERIES INSTALLATION TOOLS

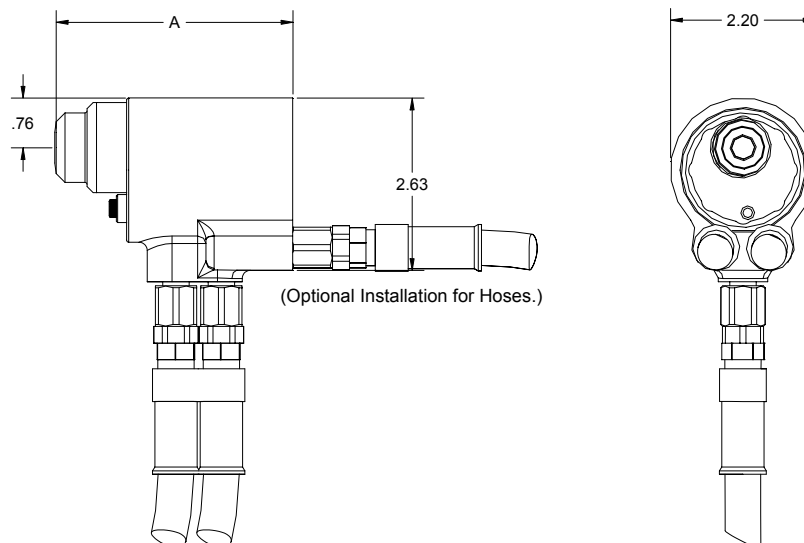

GBP508MG = 3.675 (93.3mm)
 GBP508NAS = 3.610 (91.7mm)
 GBP508SB = 3.618 (91.9mm)

GBP510FT = 3.818 (96.9mm)
 GBP510MG = 3.758 (95.5mm)
 GBP510NAS = 3.630 (92.2mm)
 GBP510SB = 3.708 (94.2mm)

GBP512MG = 3.798 (96.5mm)
 GBP512NAS = 3.642 (92.5mm)
 GBP512SB = 3.708 (94.2mm)

DESCRIPTION

The GBP500 series and the GBP500A series are hydraulic installation tools designed specifically for the efficient installation of a wide variety of lockbolt & blind bolt fasteners. These tools are unique in that they have a built in nose assembly which helps in limited clearance areas. These tools can be operated in any position with one hand. They have a .750 setting stroke and rated pull load of 10,000 lbs.

The GBP500 series installation tools operate on hydraulic pressure developed by the GBP940 Powerunit set at 5600 psi maximum PULL pressure and 2400 psi maximum RETURN pressure. The tool comes equipped with 12 feet of hydraulic hoses and couplings, electric switch and cord. The GBP500A series installation tools operate on hydraulic pressure developed by the GBP910 Powerunit set at 5600 psi maximum PULL pressure and 2400 psi maximum RETURN pressure. The tool comes equipped with 12 feet of hydraulic hoses and couplings, air trigger and tube.

All GBP hydraulic installation tools are compatible with Huck Powerunits.

GAGE BILT PRODUCTS CORP.

GAGE BILT

14500 Barber Drive (586) 771-7664
 Warren, Mi 48088 (586) 771-2665 Fax
 e-mail:solutions@gagebilt.com / www.gagebilt.com