

GBP731OS

INSTALLATION TOOL

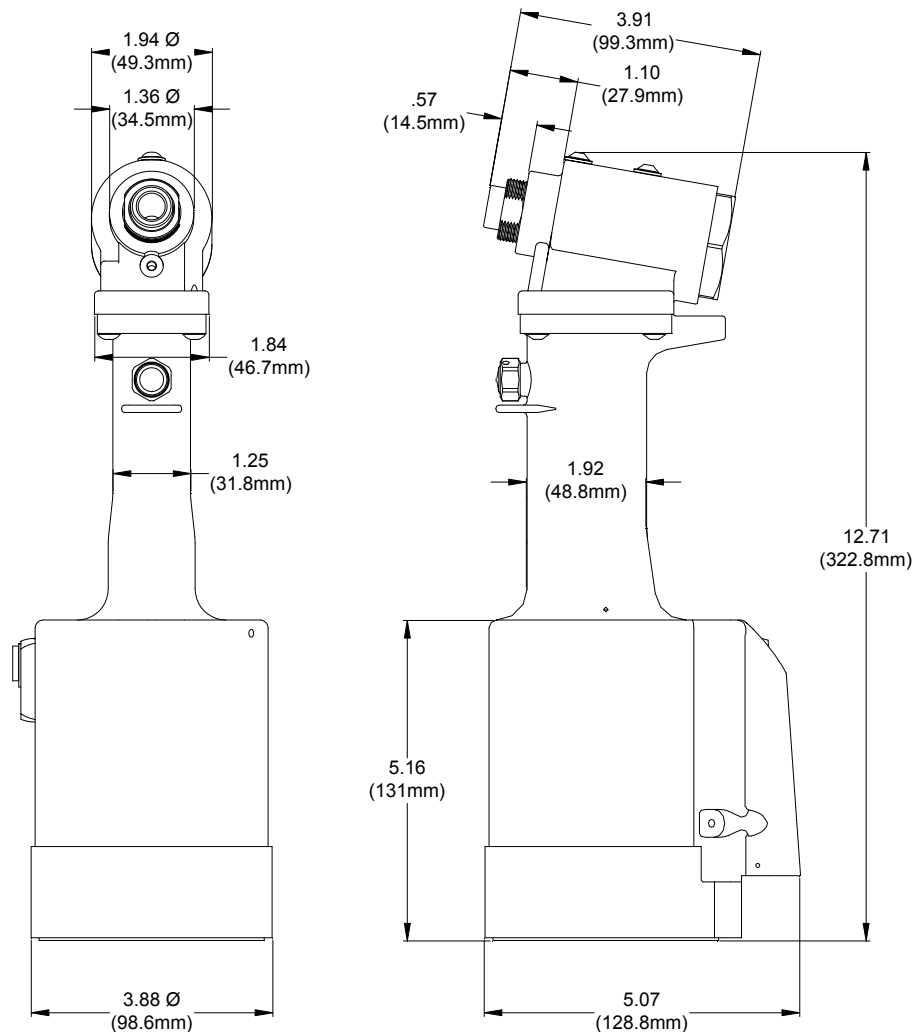

DESCRIPTION

The GBP731OS is a pneumatic-hydraulic tool designed specifically for the efficient installation of a wide range of blind rivets and lockbolts. It weighs just under 5.7 lbs. and can be operated in any position with one hand. It has a .600 rivet setting stroke and a rated pull load of 4800 pounds on 90 psi air pressure at the air inlet.

The GBP731OS riveter operates on a wide range of air pressure, with 90 to 100 psi providing the maximum efficiency. At 90 lbs. air pressure, the GBP731OS does not exceed 85 db (A) and consumes 3.9 cfm at 20 cycles per minute.

The air inlet is provided with 1/4-18 female pipe threads for accepting the user's air hose fitting.

NOSE ASSEMBLIES ARE NOT FURNISHED WITH THIS RIVETER AND MUST BE ORDERED SEPARATELY.

GAGE BILT
MADE IN U.S.A.

GAGE BILT PRODUCTS CORP.
44766 Centre Court (586) 226-1500
Clinton Twp. MI 48038 (586) 226-1505 Fax
e-mail:solutions@gagebilt.com / www.gagebilt.com

GBP731OS SELECTION CHART



FASTENER	DIA.	STANDARD	STRADDLE NOSE (1)	LONG
LOCKBOLT, NAS SHEAR PULL TYPE, NAS TENSION PULL TYPE, NASS = SHEAR & GP NAST = TENSION	5/32"	NAST05-204B-25OS	NAST05-204B-30OS	NAST05-204B-34OS
	3/16"	NASS05-204B-25OS	NASS05-204B-30OS	NASS05-204B-34OS
	1/4"	NAS06-204B-25OS	NAS06-204B-30OS	NAS06-204B-34OS
MGP	4mm	MGP4-204B-25OS	MGP4-204B-30OS	MGP4-204B-34OS
	5mm	MGP5-204B-25OS	MGP5-204B-30OS	MGP5-204B-34OS
Light weight Groove Proportion LOCKBOLT	5/32"	LGP05-204B-25OS	LGP05-204B-30OS	LGP05-204B-34OS
	3/16"	LGP06-204B-25OS	LGP06-204B-30OS	LGP06-204B-34OS
	1/4"	LGP08-204B-25OS	LGP08-204B-30OS	LGP08-204B-34OS
MLGP	4mm	MLGP4-204B-25OS	MLGP4-204B-30OS	MLGP4-204B-34OS
	5mm	MLGP5-204B-25OS	MLGP5-204B-30OS	MLGP5-204B-34OS
SINGLE ACTION BLIND RIVET NAS1919S & U NAS1921S & U	1/8"	SMLS04-204C-27OS		SMLS04-204C-37OS
	5/32"	SMLS05-204C-27OS		SMLS05-204C-37OS
	3/16"	SMLS06-204C-27OS		SMLS06-204C-37OS
	1/4"	SMLS08-204C-27OS		SMLS08-204C-37OS
MS90353S & U & MS90354S & U MS21140S & U & MS21141S & U CR7000 SERIES BACB30YY, YU, & YT	5/32"	SB05-204C-27OS		SB05-204C-37OS
	3/16"	SB06-204C-27OS		SB06-204C-37OS
	1/4"	SB08-204C-27OS		SB08-204C-37OS
MS90353 & MS90354 MS21140 & MS21141 "U" TYPE BLIND BOLT WITH DRIVE WASHER	5/32"	UBB05-204C-27OS		UBB05-204C-37OS
	3/16"	UBB06-204C-27OS		UBB06-204C-37OS
	1/4"	UBB08-204C-27OS		UBB08-204C-37OS
EN6122 & UAB130-EU EN6127 & UAB6127-EU EN6128 & UAB100-EU EN6129 & UABP-EU	5/32"	UAB05-204C-27OS		UAB05-204C-37OS
	3/16"	UAB06-204C-27OS		UAB06-204C-37OS
	1/4"	UAB08-204C-27OS		UAB08-204C-37OS
BACR15FR/FP, BACR15GF/GK, NAS1919 & NAS1921 "U" TYPE BLIND RIVET WITH DRIVE WASHER NAS9301-9312	1/4"	08MAX-204C-27OS		08MAX-204C-37OS
"A" CODE NAS1398A & NAS1399A	1/8"	4A-204C-27OS		4A-204C-37OS
	5/32"	5A-204C-27OS		5A-204C-37OS
	3/16"	6A-204C-27OS		6A-204C-37OS
	1/4"	SMLS08-204C-27OS		SMLS08-204C-37OS
ASP 2, ASP PF, ASP 4 FF, ASP 2 F, ASP 2 LC	13/64"	ASP06-204C-27OS		ASP06-204C-37OS
	17/64"	ASP08-204C-27OS		ASP08-204C-37OS
	21/64"	ASP10-204C-27OS		ASP10-204C-37OS
NAS1719, NAS1720, NAS1721 & MBC	1/8"	MBC04-204C-27OS		MBC04-204C-37OS
	5/32"	MBC05-204C-27OS		MBC05-204C-37OS
	3/16"	MBC06-204C-27OS		MBC06-204C-37OS
GROUND STUD, BACS53B	13/64"	GS8-204C-32OS		GS8-204C-42OS
	17/64"	GS10-204C-32OS		GS10-204C-42OS

THE GBP731OS IS APPROVED TO INSTALL THE ABOVE FASTENERS.

1) -30 STRADDLE NOSES ARE DESIGNED TO REACH OVER THE COLLAR.

NOTE: THE LAST 2 DIGITS OF THE NOSE ASSEMBLY REPRESENTS THE LENGTH
THE NOSE ASSEMBLY EXTENDS FROM THE TOOL. (I.e. -27 = 2.7 inches)

GAGE BILT ALSO SUPPLIES PIN & COLLAR SWAGE INSPECTION GAGES TO CERTIFY CORRECT SWAGE INSTALLATION.

