

GBP756

INSTALLATION TOOL

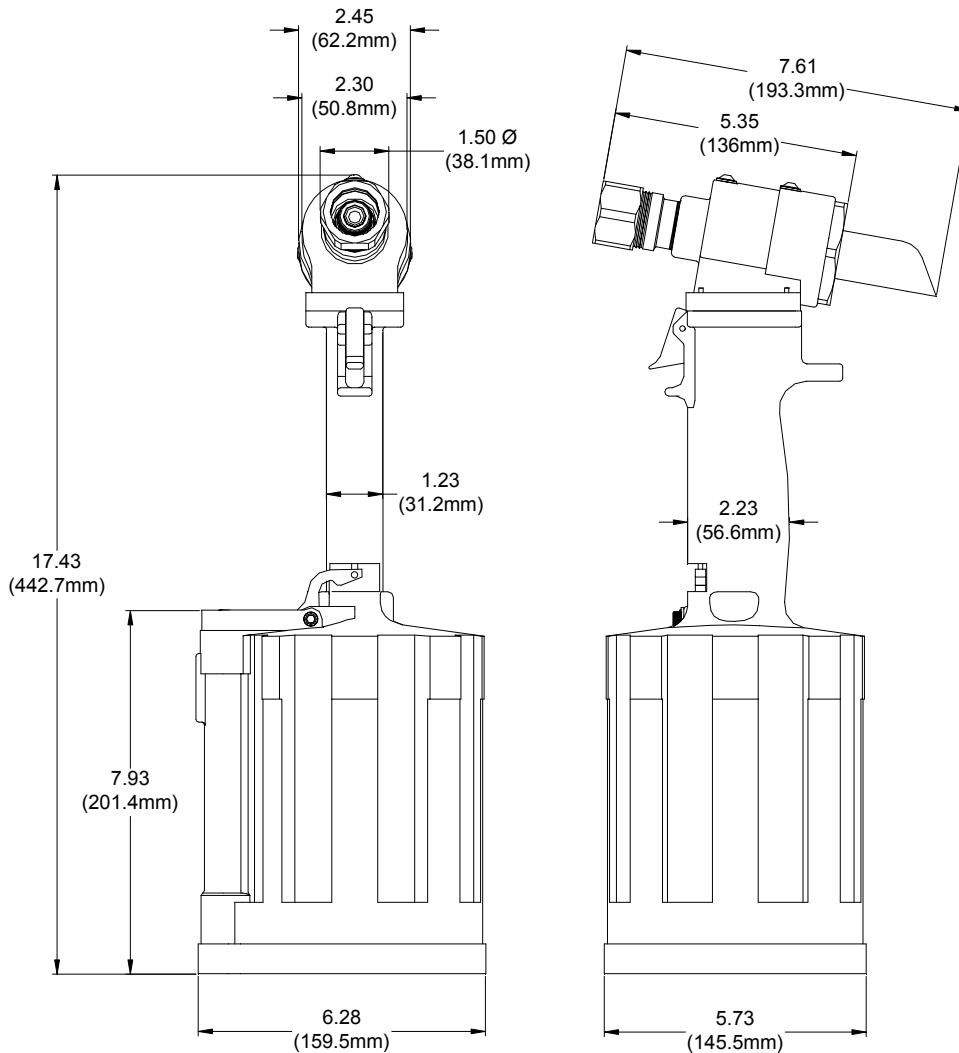

DESCRIPTION

The GBP756 is a hydraulic installation tool designed specifically for the efficient installation of a wide range of blind, lockbolt and Magna-Grip fasteners thru 3/8" diameter. It weighs 11.1 lbs. and can be operated in any position with one hand. It has a .960" rivet setting stroke and a rated pull load of 10,000 pounds.

The GBP756 riveter operates on a wide range of air pressure, with 90 to 100 psi providing the maximum efficiency. At 90 lbs. air pressure, the GBP756 does not exceed 82 db (A) and consumes 6.0 cfm at 20 cycles per minute.

The air inlet is provided with 1/4-18 female pipe threads for accepting the user's air hose fitting.

NOSE ASSEMBLIES ARE NOT FURNISHED WITH THIS RIVETER AND MUST BE ORDERED SEPARATELY.

GAGE BILT
MADE IN U.S.A.

GAGE BILT PRODUCTS CORP.

44766 Centre Court (586) 226-1500
Clinton Twp. MI 48038 (586) 226-1505 Fax
e-mail:solutions@gagebilt.com / www.gagebilt.com

SELECTION CHART FOR GBP756



FASTENER	DIA.	STRAIGHT		*OFFSET	
2 ASP & ASP PF ASP FF & ASP F ASP-LC and MAF	13/64 17/64 21/64	ASP06-745B-23 ASP08-745B-23 ASP10-755-23	ASP06-745B-48 ASP08-745B-48 ASP10-755-48	ASP06-204C-27OS ASP08-204C-27OS ASP10-204C-27OS	ASP06-204C-37OS ASP08-204C-37OS ASP10-204C-37OS
BOM AVBOLT	1/4 5/16 3/8	BOM08-755-23 BOM10-756-26 BOM12-756-26			
COMMERCIAL LOCKBOLTS C6L ADVELOK	3/16 1/4 5/16 3/8	NAS06-745B-12 NAS06-755-23 NAS08-745B-12 NAS08-755-23 LB10-745C-26 LB12-756-26	NAS06-755-48 NAS08-755-48 NAS10-756-48 NAS12-756-48	NAS06-204B-25OS NAS06-204B-34OS NAS08-204B-25OS NAS08-205A-31 NAS10-205A-31 NAS12-205A-31	NAS06-204B-30OS NAS08-204B-30OS NAS08-204B-34OS
CONTAINER BOLT	3/8	HT12-745B-28			
FLOOR BOLT	5/16	FT10-745B-26			
LGP LOCKBOLT	5/32	LGP05-745B-12 LGP05-755-48	LGP05-755-23	LGP05-204B-25OS LGP05-204B-34OS	LGP05-204B-30OS
LGPL2SC-V BACB30VM LGPL18SC-V BACB30XT	3/16	LGP06-745B-12 LGP06-755-48	LGP06-755-23	LGP06-204B-25OS LGP06-204B-34OS	LGP06-204B-30OS
LGPL4SC-V ABS0548 LGPL2SP-V BACB30VN	1/4	LGP08-745B-12 LGP08-755-48	LGP08-755-23	LGP08-204B-25OS LGP08-204B-34OS	LGP08-204B-30OS LGP08-205A-31
LGPL4SP-V ASNA2392 LGPL8SC-V BACB30WD	5/16	LGP10-745B-12 LGP10-756-48	LGP10-756-26	LGP10-205A-31	
LGPL9SC-V BACB30WB LGPL9SP-V BACB30VY	3/8	LGP12-745B-12 LGP12-756-48	LGP12-756-26	LGP12-205A-31	
NAS and GP SHEAR/TENSION LOCKBOLTS	5/32 3/16 1/4 5/16 3/8	NASS05-745B-12 NASS05-755-23 NASS05-755-48 NAS06-745B-12 NAS06-755-48 NAS08-745B-12 NAS08-755-48 NAS10-745B-12 NAS10-756-48 NAS12-745B-12 NAS12-756-48	NAST05-745B-12 NAST05-755-23 NAST05-755-48 NAS06-755-23 NAS08-755B-23 NAS10-756-26 NAS12-756-26	NASS05-204B-25OS NASS05-204B-30OS NASS05-204B-34OS NAS06-204B-25OS NAS06-204B-34OS NAS08-204B-25 NAS08-204B-34 NAS10-205A-31 NAS12-205A-31	NAST05-204B-20OS NAST05-204B-30OS NAST05-204B-34OS NAS06-204B-30OS NAS08-204B-30 NAS08-205A-31
MULTI-GRIP LOCKBOLT	3/16 1/4 5/16 3/8	MG06-745-48 MG08-745-48 MG10-756-28 MG12-756-28			
MULTI-GRIP STRUCTURAL BLIND RIVET	5/16 3/8	MGL10-353-28 MGL12-353C-28			
OVERSIZE STRUCTURAL RIVET	1/4 5/16 3/8	OS08-353A-48 OS10-756-26 OS12-756-26	OS10-756-48 OS12-756-48		
BLIND BOLTS MS90353S & U & MS90354S & U MS21140S & U & MS21141S & U CR7000 SERIES BACB30YY, YU, & YT	5/32 3/16 1/4 5/16 3/8	SB05-745B-23 SB06-745B-23 SB08-755-23 SB10-756-28 SB12-756-28	SB05-745B-48 SB06-745B-48 SB08-755-48 SB10-756-48 SB12-756-48	SB05-204C-27OS SB06-204C-27OS SB08-204C-27OS SB10-205A-35 SB12-205A-35	SB05-204C-37OS SB06-204C-37OS SB08-204C-37OS

THE GAGE BILT GBP756 TOOL IS APPROVED TO INSTALL THE ABOVE FASTENERS.

*ALL OFFSET 204 SERIES NOSES REQUIRE 353204 ADAPTER WITH 756152 STROKE LIMITER..

*ALL OFFSET 205 SERIES NOSES REQUIRE 353205 ADAPTER WITH 756153 STROKE LIMITER.

NOTE: THE LAST 2 DIGITS OF THE NOSE ASSEMBLY REPRESENTS THE LENGTH THE NOSE
EXTENDS FROM THE TOOL I.E. -20 = 2.0 INCHES



**GAGE BILT ALSO SUPPLIES PIN & COLLAR SWAGE INSPECTION
GAGES TO CERTIFY CORRECT SWAGE INSTALLATION.**

