

# GBP910C

## HYDRAULIC POWERUNIT

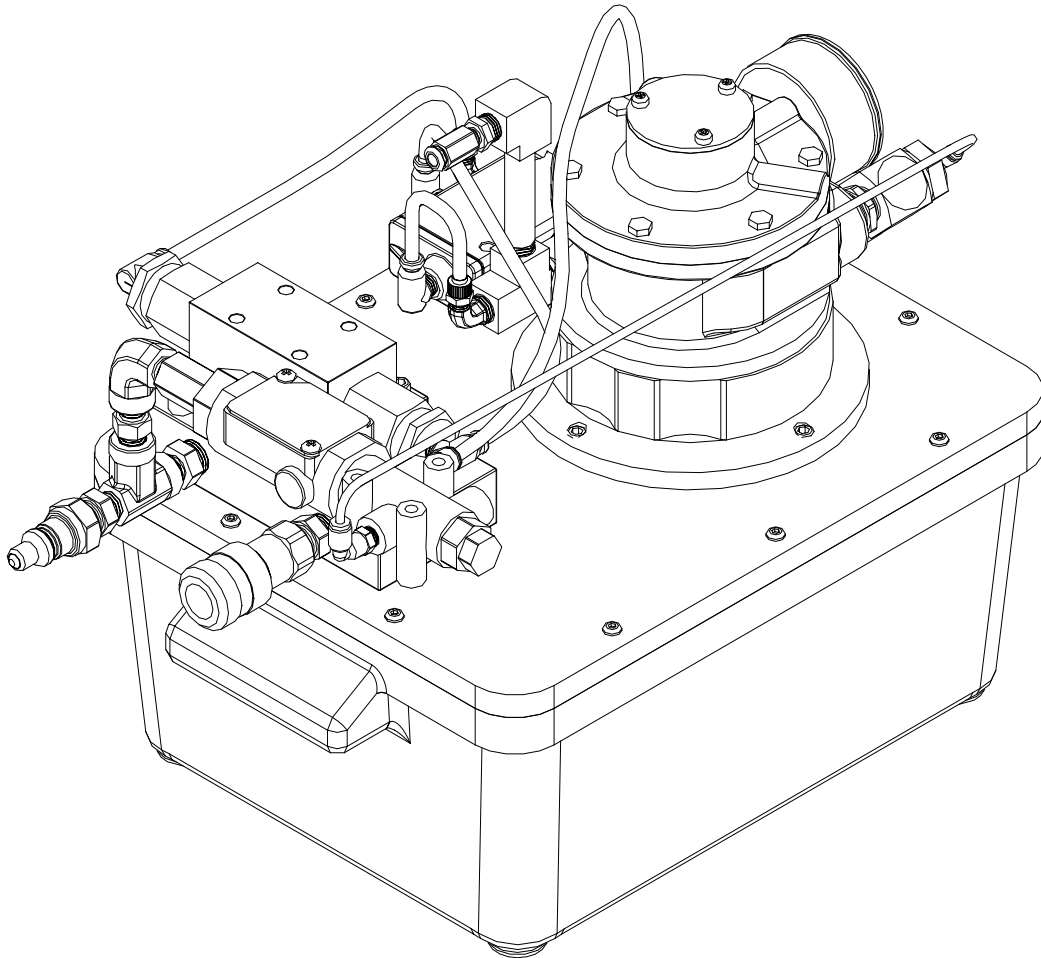

### DESCRIPTION:

The GBP910C Hydraulic Powerunit is a portable power source designed to operate a wide range of hydraulic installation tools. The unit air powered, air actuated and delivers up to 10,000 psi working pressure. The trigger on the installation tool remotely controls the hydraulic fluid directional flow. The unit consists of a two position air hydraulic pump, four way control valve and relief valve mounted on the reservoir.

The rapid tool piston movement is obtained through a higher (50 cubic inches a minute) output pump. Quick disconnect hydraulic couplings and air control socket are included to attach the equipment hydraulic hoses and air control tube.

**GAGE BILT**  
MADE IN U.S.A.

**GAGE BILT PRODUCTS CORP.**

14500 Barber Drive (586) 771-7664  
Warren, Mi 48088 (586) 771-2665 Fax  
e-mail:solutions@gagebilt.com / www.gagebilt.com



## GBP910C POWERUNIT SPECIFICATIONS



**NOTE:**

An air line filter-lubricator is highly recommended for proper operation and extended life.

**NOTE:**

Shipped with Pull pressure at 10,000 psi (68,950 kPa) & Return pressure at 6,000 psi (41,370 kPa) for GBP7500AA. When attaching GBP585A set Pull pressure to 5,400-5,700 psi (37,350-39,300 kPa) & Return pressure 2,200-2,400 psi (15,200-16,500 kPa).

Width .....	13.0 inches
Length .....	20.5 inches
Height .....	14.0 inches
Reservoir Capacity .....	2 gallons
Power Source - compressed air .....	90-100 psi
Air Consumption (continuous operation): .....	62 CFM
Remote Control-Air piloted 4-way valve actuated by a trigger in the tool	
Motor .....	Air Motor
Pump - Air Hydraulic, Rapid Advance and Swage .....	50 cu. in./min. @ 5000 psi
Output Pressure:	
Pull .....	Adjustable to 10,000 psi.

Operating temperature:

Ambient .....	min. 0 F .....	-18 C
Hydraulic Fluid...max. 150 F .....	65 C	

Hydraulic Fluid:

Standard Hydraulic Fluid with a viscosity rating of 300 SUS @ 100° F and 55 SUS @ 210° F