

GB51

PNEUMATIC INSTALLATION TOOL

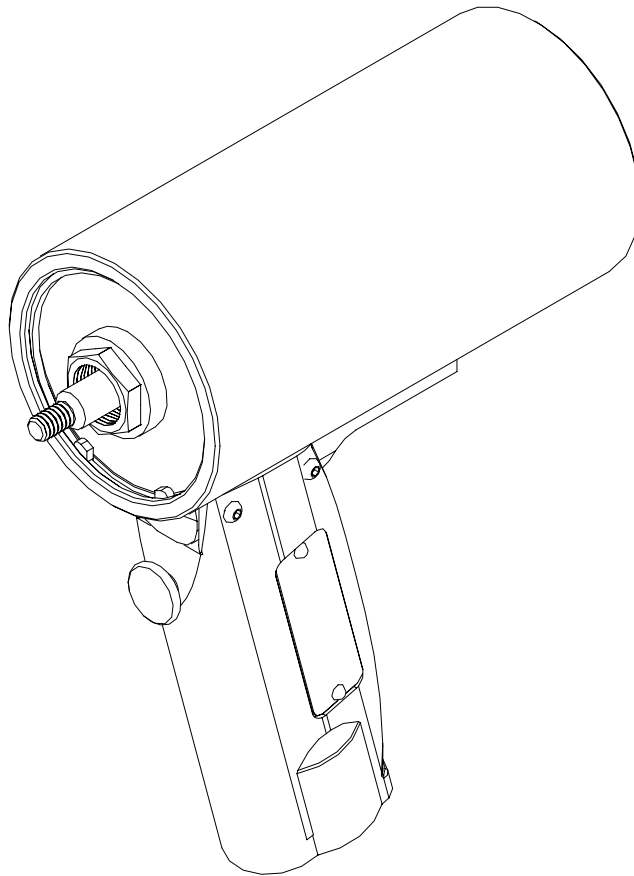

GAGE BILT

MADE IN U.S.A.

GAGE BILT PRODUCTS CORP.

44766 Centre Court (586) 226-1500
Clinton Twp. MI 48038 (586) 226-1505 Fax
e-mail: solutions@gagebilt.com / www.gagebilt.com

TABLE OF CONTENTS

<u>Description</u>	<u>Page</u>
Warnings.....	3
Description, Operation and Maintenance.....	4
Parts List.....	5
Nose Assembly Selection Chart.....	6

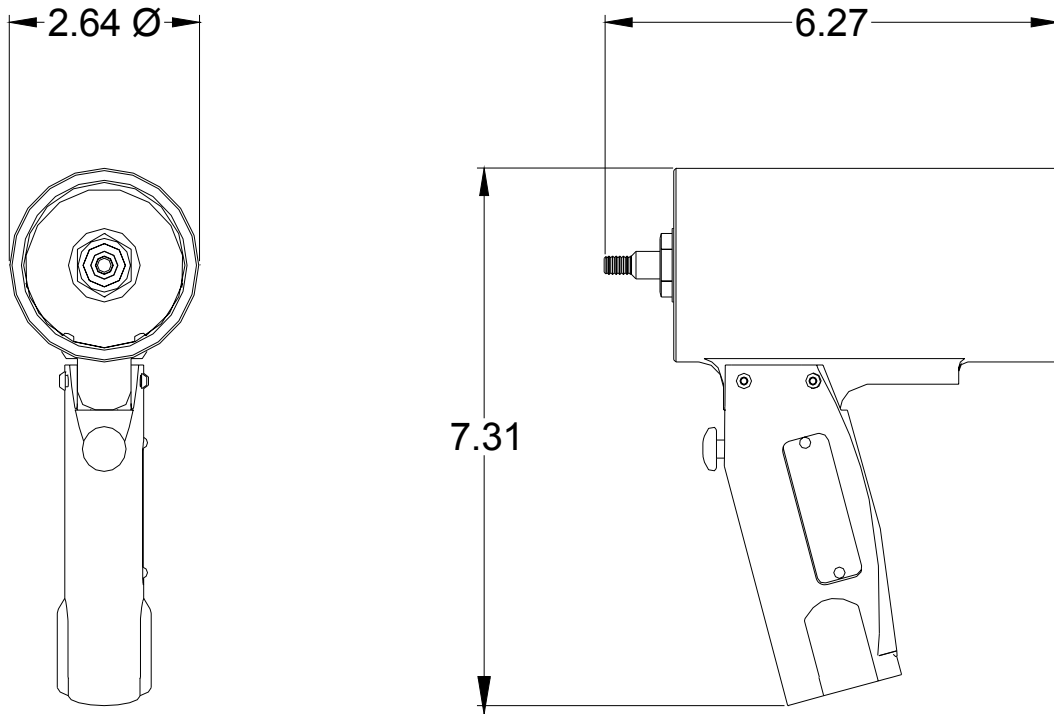

SPECIFICATIONS

- Hand Held Weight** - 2.50 lbs.
- Air pressure req'd** - 90-120 p.s.i.
- Air consumption** - .29 SCF/cycle (8.21 L/cycle)
- Hydraulic fluid** - Automatic Transmission Fluid, Dextron III, or equivalent.
- Setting stroke** - .740"
- Noise level** - Less than 80 dB (A)
- Rated pull load** - 1000 lbs.



NOTE:

PLEASE READ THIS MANUAL BEFORE SERVICING OR USING THIS TOOL. COMPLETE WITH WARNINGS AND CAUTIONS TO PREVENT SEVERE PERSONAL INJURY OR DAMAGE THE TOOL.



CAUTION:

GAGE BILT TOOLS ARE APPROVED TO INSTALL HUCK®, AVDEL®, CHERRY®, POP® AND OTHER FASTENERS WHEN USED BY PERSONS WITH SPECIFIC TRAINING OF BLIND RIVET AND LOCKBOLT INSTALLATION EQUIPMENT.

WARNING

Do not pull fastener unless it is placed in an assembly, pin will eject forcibly when pintail breaks off. Severe personal injury may result.

WARNING

Always disconnect tool from power before performing any maintenance to any tool or nose assembly. Insure that all connections are proper and there are no visible leaks from tool or hoses before connecting to power.

WARNING

When operating installation equipment always wear approved eye protection. Do not look in front of nose assembly or rear of tool when installing fastener.

CAUTION

Insure that nose assembly and tip are properly matched for the fastener being installed.

WARNING

Installation of fasteners may exceed acceptable noise levels. Use approved hearing protection.

WARNING

Be sure there is adequate clearance for tool and operator's hands before proceeding. Keep fingers clear of any moving parts. Keep fingers clear from fasteners and installed materials. Severe personal injury may result.

CAUTION

Keep Nose Assemblies clean and free of chips and debris.

DESCRIPTION

The GB51 pneumatic riveter is designed specifically for the most efficient installation of a wide range of blind rivets. It will install aluminum rivets through 3/16" diameter, and through 1/8" diameter rivets in any material. It weighs only 2 1/2 lbs. and can be operated in any position with one hand.

The GB51 Riveter is 7" high, has a .740 stroke and generates a minimum of 1000 lbs. of pull at 90 psi. It operates from 80 to 110 psi of air pressure at the tool.

NOSE ASSEMBLIES ARE NOT FURNISHED WITH THIS TOOL AND MUST BE PURCHASED SEPARATELY.

OPERATION

- 1) To install screw-on pulling head, thread head to tool drawbolt (7) while threading the head housing into installation tool (1) at the same time tighten locknut to hold the ejection slot of the pulling head in the desired position. This slot position is usually down so used rivet stems fall down out of the nose assembly by gravity.
- 2) Install 1/4" air fitting into bottom of handle (19). Only use an air supply set at 80 - 110 lbs. equipped with a filter-regulator-lubricator to prevent wear.
- 3) Always hold tool so pulling head is perpendicular to surface of material in which rivet is being installed. Exert firm pressure against rivet during installation.

MAINTENANCE AND SERVICE

The performance of any tool depends on good maintenance practices. This tool could require periodic replacement of seals and o'rings. The seals requiring most frequent replacement are the O'rings (4) and the O'ring (5). The cushion (12) will eventually require replacement with use. Keep the exhaust port in the center of the back cap (13) clear of debris at all times. Disassembly of the head portion of the tool is accomplished as follows: Using a truarc plier, remove retaining ring (3) which allows removal of back cap (13) and cushion (12). Double nut front end of drawbolt (7) using 1/4-28 nut, then remove connector bolt (11) permitting removal of retaining ring (3) and rear piston (8). Remove front retaining ring (3) and withdraw front seal (6). Remove the front piston (8), permitting removal of the sleeve (9). The triple piston chambers are separated by dividers (10) which may be removed by removing the rings (3). **Caution:** When replacing the dividers (10), care should be taken to replace the retaining rings (3) so they do not block the air ports at the bottom of the cylinder where the handle attaches.

CLEANING AND LUBRICATING PROCEDURE

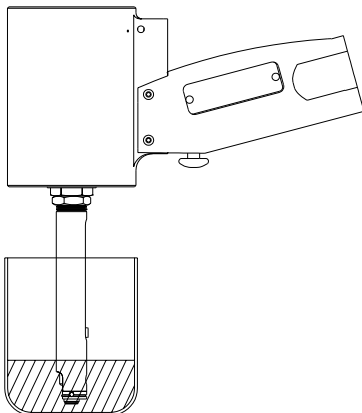

Daily cleaning and lubrication of nose assembly will greatly reduce downtime and increase life of components. Using sewing machine oil, or an equivalent cleaner/lubricant, follow instructions below.

1. Disconnect tool vacuum line (if equipped).
2. Point nose assembly into oil as shown.
3. Cycle tool 8-10 times and wipe dry.

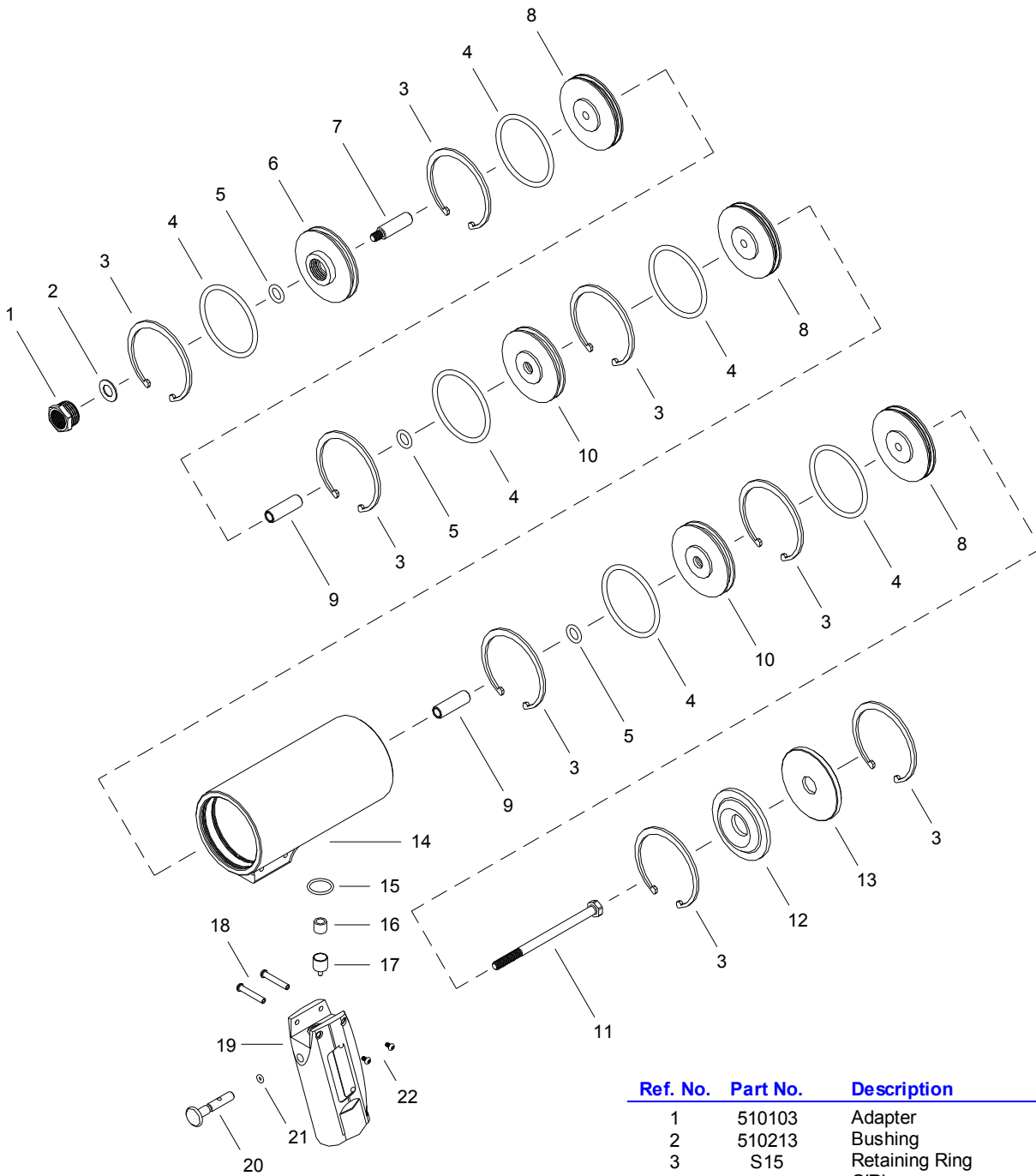

Ref. No.	Part No.	Description	Qty.
1	510103	Adapter	1
2	510213	Bushing	1
3	S15	Retaining Ring	8
4	400858	O'Ring	6
5	400807	O'Ring	3
6	510119	Front Seal	1
7	510217	Drawbolt	1
8	510101	Piston	3
9	510104	Sleeve	2
10	510102	Divider	2
11	S17	Connector Bolt	1
12	510114	Cushion	1
13	510118	Back Cap	1
14	510121	Head Assembly	1
15	400782	O'Ring	1
16	510105	Seal	1
17	510125	Seat	1
18	510215	Dowel Screw	2
19	510320	Handle	1
20	510107	Trigger	1
21	400772	O'Ring	1
22	A-819	Button Head Screw	2

GB51 SELECTION CHART

FASTENER	DIA.	STRAIGHT	RIGHT ANGLE ₁	OFFSET
NUT PLATE RIVETS MS20600 SERIES CCR244/264/274 MS/9SP/PT BACR15CC/CF/DA/DR	3/32 1/8 5/32 ₃ 3/16 ₃	3C-715B-43 4C-715B-43 5C-715B-43 6C-715B-43	3C-715-54RA 4C-715-54RA 5C-715-54RA 6C-715-54RA	3C-715-40OS 4C-715-40OS 5C-715-40OS 6C-715-40OS
"A" CODE NAS1398A, NAS1399A NAS1740A, NAS1739A	3/32 1/8 5/32 ₃ 3/16 ₅	3A-715B-43 4A-715B-43 5A-715B-43 6A-715B-43	3A-715-54RA 4A-715-54RA 5A-715-54RA 6A-715-54RA	3A-715-40OS 4A-715-40OS 5A-715-40OS 6A-715-40OS
SINGLE ACTION BLIND RIVET NAS1919S & U NAS1921S & U	1/8 5/32 ₃ 3/16 ₃	SMLS04-715B-43 SMLS05-715B-43 SMLS06-715B-43	SMLS04-715-54RA SMLS05-715-54RA SMLS06-715-54RA	SMLS04-715A-40OS SMLS05-715A-40OS SMLS06-715A-40OS
BACR15FR/FP, BACR15GF/GK, NAS1919 & NAS1921 "U" TYPE BLIND RIVET WITH DRIVE WASHER NAS9301-9312	1/8 5/32 ₄	456MAX-715-43 ₂	456MAX-715A-54RA ₂	456MAX-715A-40OS ₂
N, Q & E POP®, CLOSED END AVEX® & COMMERCIAL RIVETS	3/32 1/8 5/32 ₃ 3/16 ₃	3N-715E-43 4N-715E-43 5N-715E-43 6N-715E-43	3N-715-54RA 4N-715-54RA 5N-715-54RA 6N-715-54RA	3N-715-40OS 4N-715-40OS 5N-715-40OS 6N-715-40OS

THE GAGE BILT GB51 TOOL IS APPROVED TO INSTALL THE ABOVE FASTENERS.

1) RIGHT ANGLE NOSE ASSEMBLYS MAY REQUIRE MORE THAN ONE PULL.
2) INSTALLS 1/8 & 5/32 DIAMETERS.
3) ALUMINUM ONLY.
4) ALUMINUM SLEEVE STEEL STEM REQUIRES 100 P.S.I.
5) SELF-PLUGGING ALUMINUM ONLY
*ALL COUNTERSUNK 'C' NOSE ASSEMBLIES MAY BE USED TO INTSALL BOTH UNIVERSAL & COUNTERSUNK HEAD RIVETS

NOTE: THE LAST 2 DIGITS OF THE NOSE ASSEMBLY REPRESENTS THE LENGTH THE NOSE
EXTENDS FROM THE TOOL I.E. -20 = 2.0 INCHES

WARRANTY

Seller warrants that all goods covered by this catalog will conform to applicable specifications and will replace, or repair, F.O.B. our plant, any goods providing defective from faulty workmanship, or material, for 90 days from date of shipment.

Said warranty to remain in effect if and only if such goods are used in accordance with all instructions as to maintenance, operation, and use set forth in manuals and instruction sheets furnished by seller.

Sellers obligation under this warranty shall be limited to the repair or rework of the goods supplied or replacement thereof, at Seller's option, and in no case is to exceed the invoice value of said goods. Under no circumstances will seller be liable for incidental or consequential damages or for damages incurred by the buyer or subsequent user in repairing or replacing defective goods or if the goods covered by this warranty are reworked or subjected to any type of additional processing.

This warranty is void if Seller is not notified in writing of any rejections or defects within 90 days after the receipt of the material by the customer.

THIS WARRANTY IS MADE IN LIEU OF ALL OTHER WARRANTIES, EXPRESS OR IMPLIED, INCLUDING MERCHANTABILITY.