

GB756

INSTALLATION TOOL

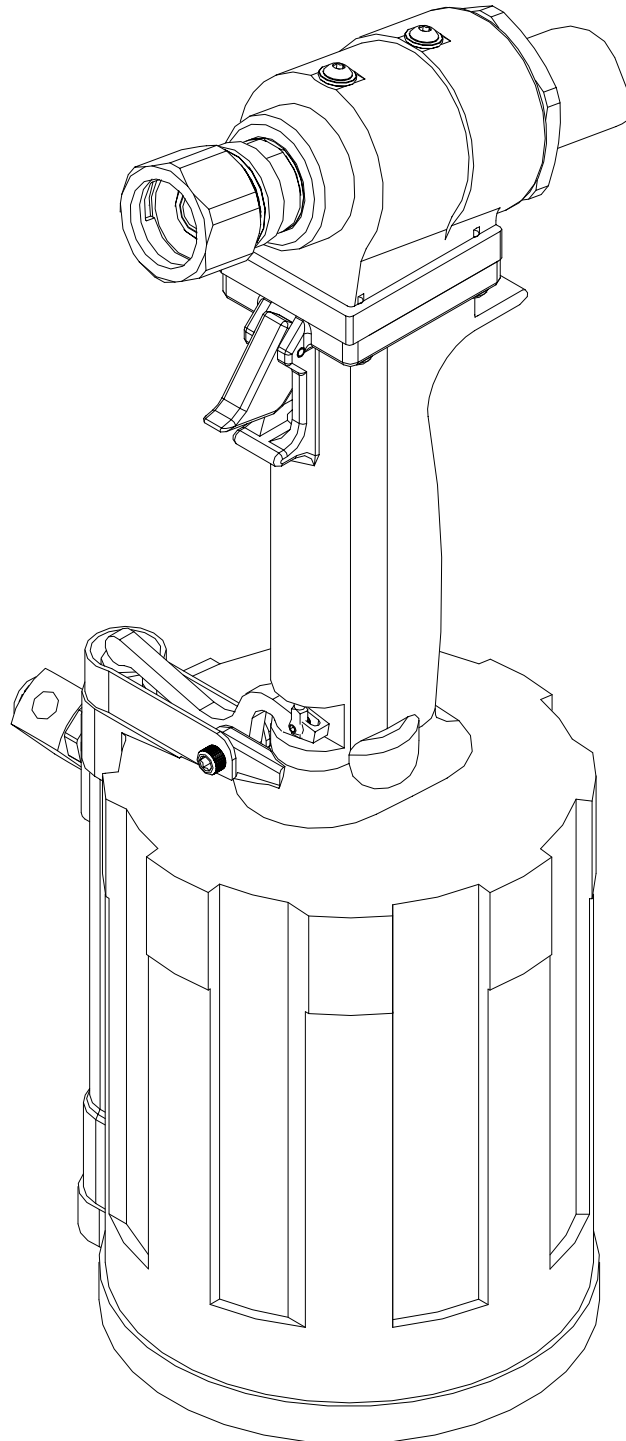

GAGE BILT TOOLS ARE AVAILABLE WORLDWIDE
E-MAIL US FOR A DISTRIBUTOR NEAR YOU.

GAGE BILT
MADE IN U.S.A.

GAGE BILT Inc.
44766 Centre Court (586) 226-1500
Clinton Twp. MI 48038 (586) 226-1505 Fax
e-mail: solutions@gagebilt.com / www.gagebilt.com

TABLE OF CONTENTS

<u>Description</u>	<u>Page</u>
Warnings.....	3
Description, Operation and Maintenance.....	4
Filling & Bleeding	5
Trouble Shooting.....	6
Assembly & Disassembly.....	7
Parts List.....	8-9
DEXRON® III Oil Safety Data.....	10
Nose Assembly/Stroke Limiter Attachment.....	11
Nose Assembly Selection Chart.....	12
EU Conformity and Warranty.....	13

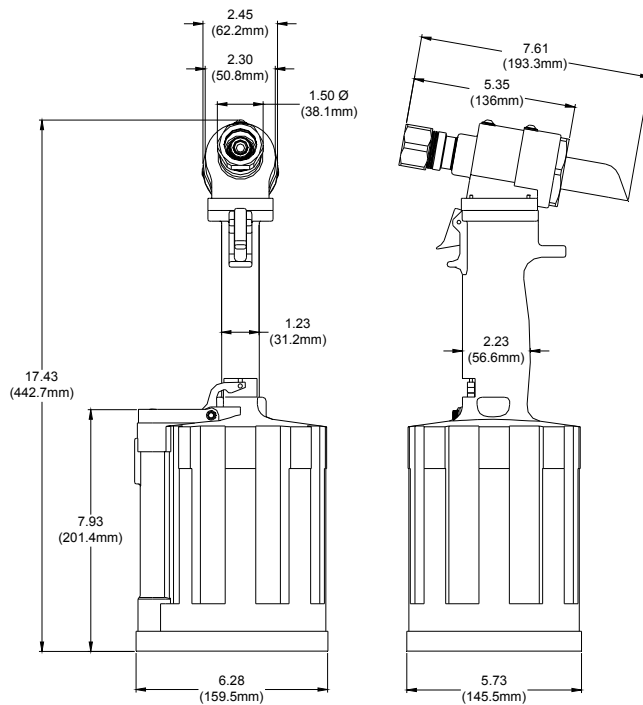

SPECIFICATIONS

- | | |
|---------------------------|---|
| Hand Held Weight | - 11.1 lbs. |
| Air pressure req'd | - 90-100 p.s.i. |
| Air consumption | - .29 SCF/cycle (8.21 L/cycle) |
| Hydraulic fluid | - Automatic Transmission Fluid, Dexron® III, or equivalent. |
| Setting stroke | - .960" |
| Noise level | - Less than 80 dB (A) |
| Rated pull load | - 10,000 lbs. |
| Vibration | - less than 2.5 M/S ² |

SAFETY WARNINGS



NOTE:
PLEASE READ THIS MANUAL BEFORE SERVICING OR USING THIS TOOL.
REVIEW ALL WARNINGS AND CAUTIONS TO PREVENT
SEVERE PERSONAL INJURY OR DAMAGE THE TOOL.



CAUTION:
GAGE BILT TOOLS ARE ONLY APPROVED TO INSTALL HUCK®, AVDEL®, CHERRY®, POP® AND
OTHER FASTENERS WHEN USED BY PERSONS WITH SPECIFIC TRAINING OF BLIND RIVET AND
LOCKBOLT INSTALLATION EQUIPMENT.

WARNING

Do not pull fastener unless it is placed in an assembly, pin will eject forcibly when pintail breaks off. Severe personal injury may result.

WARNING

Do not operate without Stat-O-Seal (A-1055) and cap screws (402482 & 402483). Pressurized hydraulic fluid may cause severe personal injury.

WARNING

When operating installation equipment always wear approved eye protection. Do not look in front of nose assembly or rear of tool when installing fastener.

WARNING

Always disconnect tool from power before performing any maintenance to any tool or nose assembly. Ensure that all connections are proper and there are no visible leaks from tool or hoses before connecting to power.

WARNING

Do not operate if deflector, bottle, catcher bag or vacuum tube is removed or damaged, broken pintails may eject forcibly from rear of tool. Severe personal injury may result.

CAUTION

Ensure that nose assembly and tip are properly matched for the fastener being installed.

WARNING

Installation of fasteners may exceed acceptable noise levels. Use approved hearing protection.

WARNING

Be sure there is adequate clearance for tool and operator's hands before proceeding. Keep fingers clear of any moving parts. Keep fingers clear from fasteners and installed materials. Severe personal injury may result.

CAUTION

Keep Nose Assemblies clean and free of chips and debris.

WARNING

Air pressure not to exceed 100 psi., except where noted.

DESCRIPTION

The GB756 is a hydraulic installation tool designed specifically for the efficient installation of a wide range of blind, lockbolt and Magna-Grip® fasteners thru 3/8" diameter. It weighs 11.1 lbs. and can be operated in any position with one hand. It has a .960" rivet setting stroke and a rated pull load of 10,000 pounds.

The GB756 riveter operates on a wide range of air pressure, with 90 to 100 psi providing the maximum efficiency. At 90 psi. air pressure, the GB756 does not exceed 81.5 db (A) and consumes 6.0 cfm at 20 cycles per minute.

The air inlet is provided with 1/4-18 female pipe threads for accepting the user's air hose fitting.

Nose Assemblies that were designed for the model 353 installation tool mount directly on the GB756 without the use of an adapter.

Nose Assemblies that were designed for the model 352 installation tool will attach to the GB756 with the use of the 353352 nose assembly adapter.

NOSE ASSEMBLIES ARE NOT FURNISHED WITH THIS TOOL AND MUST BE ORDERED SEPARATELY (SEE PAGE 12).

MAINTENANCE

The performance of any tool depends upon good maintenance practices. Following these minimal requirements for service and care will extend the life of your tool.

- *Only use an air supply set at 90-100 psi. equipped with a filter-regulator to prevent wear.
- *The tool will eventually lose some hydraulic oil. Keep the hydraulic system full and free of air by using the air bleeder (745163) on a regular basis.
- *Proper care by operator is necessary in maintaining full productivity and reducing down time. Read all applicable tool manuals and nose assembly data sheets prior to operating tools.
- *Keep nose assemblies, especially jaws, clean and free of chips and debris.
- *For a complete overhaul, tool kit GB756TK is recommended.

TORQUE SPECIFICATIONS

Button Head Cap Screws (402479) = 35-40 inch lbs.
Packing Plug (756118) = 45 foot lbs.
Flexlock Nut (A-1089) = 40 inch lbs.
End Cap (756116) = 50 foot lbs

FILLING AND BLEEDING INSTRUCTIONS

WARNING:

Do not cycle tool without screws or bleeder bottle installed in cylinder head. Severe personal injury may occur.

To replace a small amount of oil in the tool start at step 7 below.

Should it become necessary to completely refill the tool (as would be required after tool has been dismantled and reassembled), take the following steps.

1. Ensure the air piston is at the full bottom of its stroke, by pushing the piston rod assembly down until it stops.
2. Fill the power cylinder and both oil passages to the top of counterbore, this should be done with the glands removed.
3. Place both glands into top of handle being careful not to tear o'rings when installing.
4. Push piston in head cylinder to its full forward position (see 'A' dimension below).
5. Install gasket (756148) and head cylinder (756200) onto top of handle being careful not to tear o'rings on glands.
6. Install the four screws into the head cylinder and tighten evenly.
7. Make sure head cylinder is in its full forward position (dimension 'A') and remove the front screw and seal from the head cylinder and attach 4 oz. bottle assembly (745163).
8. Squeeze bottle gently until no air rises into the bottle being careful not to move head piston.
9. Remove 4 oz. bottle assembly (745163) from the front hole and replace screw & seal tightening to 35-40 inch pounds.
10. Remove rear screw and seal and attach 4 oz. bottle assembly (745163). Squeeze bottle gently until no air rises into bottle.
11. With front screw and seal tightened to 35-40 inch pounds, and the 4 oz. bottle attached to the rear hole, connect tool to air with the pressure being set to 40-50 psi.
12. Cycle tool 10 times, holding the trigger down for 5 seconds and releasing the trigger for 5 seconds.
13. Depress trigger and hold until the piston is in its full rear position (see dimension 'B' below) then disconnect tool from air.
14. Remove 4 oz. bottle assembly from rear hole and replace screw and seal tightening to 35-40 inch pounds.
15. Connect tool to air, the piston should move to its full forward position (see dimension "A" below). Remove front screw and seal and attach 4 oz. bottle assembly.
16. Cycle tool 10 times holding trigger for 5 seconds and releasing trigger for 5 seconds.
17. With head piston in its full forward position (see dimension 'A' below), disconnect tool from air remove 4 oz. bottle assembly and tighten screw and seal to 35-40 inch pounds.
18. Make sure screw and seals are torqued to 35-40 inch pounds to prevent leaking and severe personal injury.
19. Connect tool to air supply and check stroke by verifying dimension 'A' and dimension 'B' as shown below.
20. If stroke check ok the bleeding procedure is complete. If not disconnect air with piston in its full forward position (see dimension 'A' below).
21. If piston does not come completely forward (see dimension 'A' below) remove both front and rear screws and seals and push piston, thru rear of cap on head cylinder, full forward until it stops (see dimension 'A' below) and repeat bleeding procedure beginning at step 7.

CAUTION: Use CAUTION when removing screws and 4oz bottle assy. hydraulic fluid may be under pressure.

WARNING: Failure to follow these instructions carefully may result in severe personal injury.

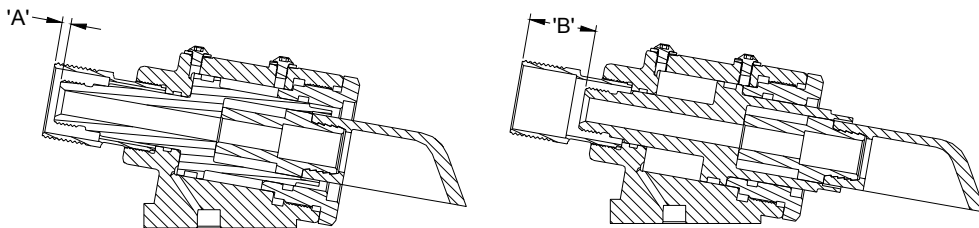

TOOL	STROKE LIMITER	STROKE LIMITER THICKNESS	STROKE	"A"	"B"
GB756	NONE	-	.96" 24.38mm	.147" 3.73mm	1.107" 28.12mm
	756152	.280	.68" 17.27mm	.147" 3.73mm	.827" 21.01mm
	756153	.210	.75" 19.05mm	.147" 3.73mm	.897" 22.78mm
	756155	.585	.375" 9.53mm	.147" 3.73mm	.522" 13.26mm

TROUBLE SHOOTING

Providing all maintenance conditions have been met, follow this systematic approach to diagnosis.

1. **MORE THAN ONE PULL IS REQUIRED TO BREAK RIVET.**
 - a) Tool needs to be bled. (See filling and bleeding instructions.)
 - b) Jaws are stripped or packed with chips. Clean or replace.
 - c) Incorrect nose assembly.
2. **SLOW OR PARTIAL OPERATION WHEN THE TRIGGER IS DEPRESSED**
 - a) Head Piston Rings (403815) and (401119) could be worn or damaged. Replace.
 - b) Piston Rod Rings (403770) and (401086) could be worn or damaged. Replace.
3. **NO OPERATION WHEN TRIGGER IS DEPRESSED**
 - a) Tool seized due to mechanical failure or damaged parts.
4. **OIL LEAKAGE**
 - a) **DO NOT** OPERATE WITH OIL LEAKING FROM TOOL. HIGH PRESSURE OIL MAY CAUSE SEVERE PERSONAL INJURY.
 - b) Any oil leaking externally should be traced to its source. An o'ring or seal that leaks should be replaced.
5. **AIR BYPASS FROM THROTTLE VALVE HOUSING**
 - a) If the spring (50607) breaks, air will flow freely through the muffler (756145). Replace.
 - b) Check o'rings on throttle valve (756140). If worn or damaged, replace.
6. **FASTENER STEM JAMMED IN NOSE ASSEMBLY**
 - a) Nose assembly components require service. **DISCONNECT AIR FROM TOOL**, remove the nose from the tool and disassemble. Replace worn or broken parts. Clean the surface the jaws ride on.
 - b) Stems lodged side by side in the follower. Disassemble, remove stems, and reassemble.
 - c) Incorrect follower.

OVERHAUL

The disassembly and re-assembly procedure can be accomplished by utilizing the following instructions and drawings. Use extreme care during disassembly and re-assembly not to mar or nick any smooth surface that comes in contact with seals. Before installing seals, always apply a good lubricant, such as Lubriplate®, to the surfaces. It is recommended that tool kit (GB756TK) be used to facilitate overhaul. A complete overhaul can be achieved by the use of Service Kit 756001 which contains a complete set of o'rings, back-up rings, screws, washers and gasket.

WARNING

DEPRESS TRIGGER AND DISCONNECT FROM AIR WITH HEAD PISTON IN THE REAR POSITION BEFORE OVERHAUL. SEVERE PERSONAL INJURY MAY OCCUR IF AIR HOSE IS NOT DISCONNECTED. USE CAUTION WHEN FORCING PISTON ROD ASSEMBLY DOWNWARD WITH HEAD CYLINDER ASSEMBLY REMOVED, HYDRAULIC FLUID WILL EJECT FORCIBLY FROM HANDLE.

LUBRICATING AND CLEANING PROCEDURE

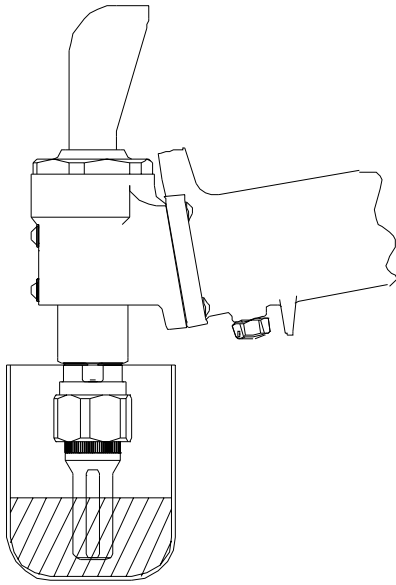

Daily cleaning and lubrication of nose assembly will greatly reduce downtime and increase life of components. Using sewing machine oil, or an equivalent cleaner/lubricant, follow instructions below.

1. Disconnect tool vacuum line (if equipped).
2. Point nose assembly into oil as shown.
3. Cycle tool 8-10 times and wipe dry.

HEAD

Remove nose assembly from tool before attempting disassembly of head assembly.

Remove deflector (756120) and end cap (756116). Push against threaded end of head piston assembly (756211) to slide it out of head cylinder (756200). Be careful not to damage threads or cause burrs on polished piston rod surface.

The re-assembly sequence is the opposite of disassembly. (See Filling and Bleeding instructions.) Apply Loctite® #242 and torque the four button-head cap screws (402479) uniformly to 35-40 inch lbs. to prevent leakage around the gasket.

HANDLE

To inspect air cylinder bore, remove bottom plate (756144), spring (50607), muffler (756145), o'ring (400777), gasket (756149), retaining ring (A-1086) and base cover (756124). Any further disassembly will require removal of the head cylinder (756200) first. For complete disassembly, start by removing bottom plate (756144), muffler (756145), o'ring (400777), gasket (756149), retaining ring (A-1086) and base cover (756124). Next, holding tool upright, remove four button-head cap screws (402479). Lift head cylinder (756200), gasket (756148) and glands (756125 & 756126) from handle (756129). Empty all hydraulic fluid into a container. Place tee wrench down into top of power cylinder into hex on piston rod assy. (756134). While holding this wrench, remove flexlock nut (A-1089) using a 9/16" socket wrench. Still holding piston rod wrench, remove air piston (756121) using a packing plug wrench (756150), by turning counterclockwise. When air piston is completely free from piston rod, tap or push on the piston rod wrench to eject air piston from bottom of handle. After removal of air piston, slide piston rod (756134) back up to the end of its travel. Using packing plug wrench (756150) remove packing plug (756118) then slide out piston rod assembly (756134).

To reassemble the handle, reverse the above procedure, being certain that all o'rings are properly lubricated before installation. Torque packing plug (756118) to 45 foot lbs. Push piston rod (756134) thru the packing plug (756118). Attach air piston (756121) and flexlock nut (A-1089) torque flexlock nut to 40 inch lbs. With the piston rod in the down position, fill oil passages on top of handle with automatic transmission fluid, DEXRON III or equivalent (See Filling & Bleeding instructions).

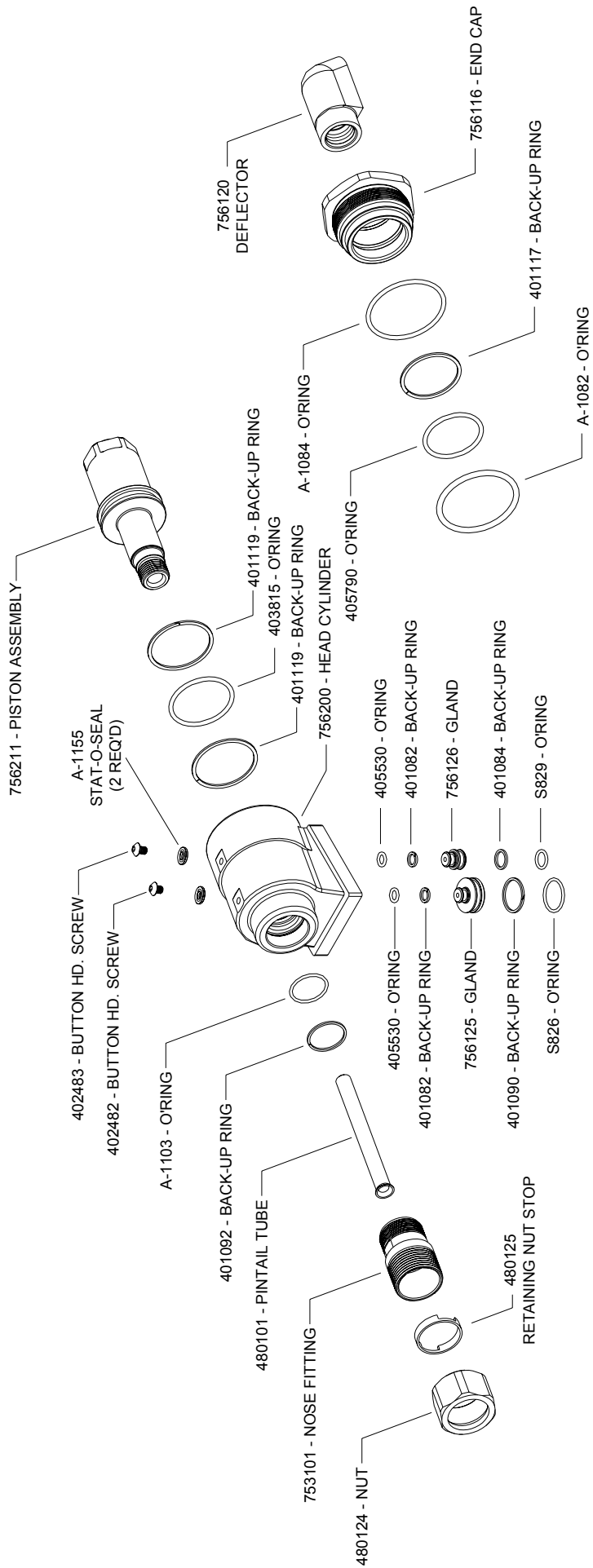

400621 - PIN

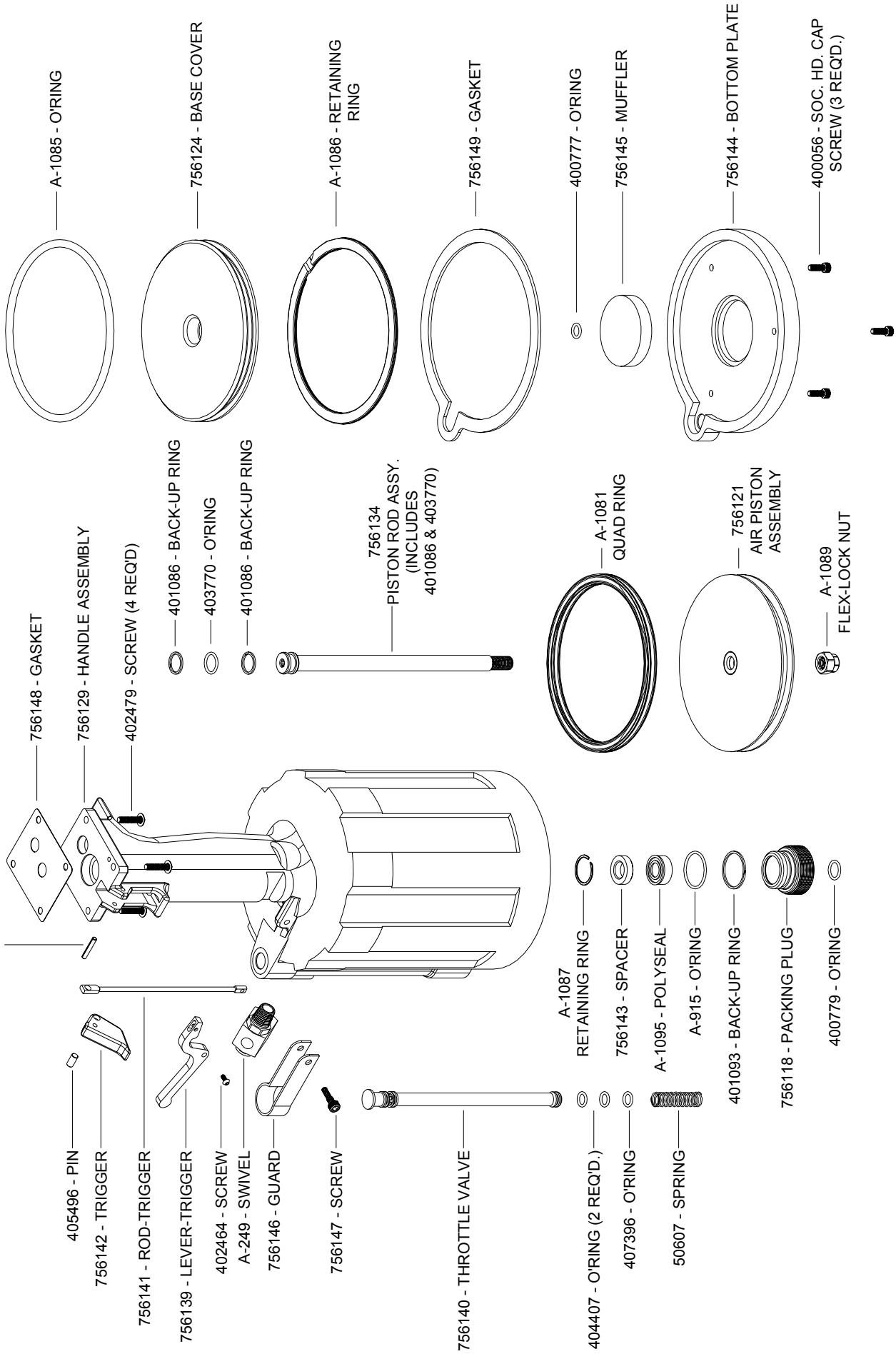

DEXRON® III OIL SAFETY DATA

FIRST AID

Skin: Wash thoroughly with soap and water as soon as possible. Casual contact requires no immediate attention. If irritation develops, consult a physician.

Ingestion: Seek medical attention immediately. DO NOT INDUCE VOMITING.

Eyes: Flush with copious amounts of water. If irritation develops, consult a physician.

Inhalation: No significant adverse health effects are expected to occur on short term exposure. Remove from contaminated area. Apply artificial respiration if needed. If unconscious, consult a physician.

FIRE

Suitable extinguishing media: CO₂ dry powder, foam or water fog. DO NOT use water jets.

ENVIRONMENT

Waste disposal: In accordance with all environmental laws and regulations applicable to your area.

Spillage: Prevent entry into drains, sewers and water course. Soak up with diatomaceous earth or other inert material. Store in appropriate container for disposal.

HANDLING

Eye protection required. Protective gloves recommended. Chemically resistant boots and apron recommended. Use in well ventilated area.

COMBUSTIBILITY

Slightly combustible when heated above flash point. Will release flammable vapor which can burn in open or be explosive in confined spaces if exposed to source of ignition.

PROPERTIES

Specific Gravity 0.863

Weight per gallon 7.18

Open flash point >200°C (392°F)

NOSE ASSEMBLIES

Nose assemblies are attached using a 1-1/4 inch socket on the rear of the piston. A-1307 socket may be ordered separately from Gage Bilt. GB745TK tool repair kit may also be ordered separately which includes A-1307 socket and other tools needed for complete tool overhaul.

When attaching offset and right angle nose assemblies an adapter and stroke limiter is necessary. Refer to nose assembly selection chart on page 12 for the adapter and stroke limiter for your specific nose assembly. Follow instructions below for installation of stroke limiter.

STROKE LIMITERS ARE DESIGNED FOR THE PROTECTION OF THE OPERATOR AND EQUIPMENT. FAILURE TO OPERATE TOOL WITH STROKE LIMITER AS REQUIRED WILL RESULT IN DAMAGE TO NOSE ASSEMBLY OR TOOL AND MAY RESULT IN PERSONAL INJURY. IF UNSURE YOUR NOSE ASSEMBLY REQUIRES A STROKE LIMITER CONTACT GAGE BILT.

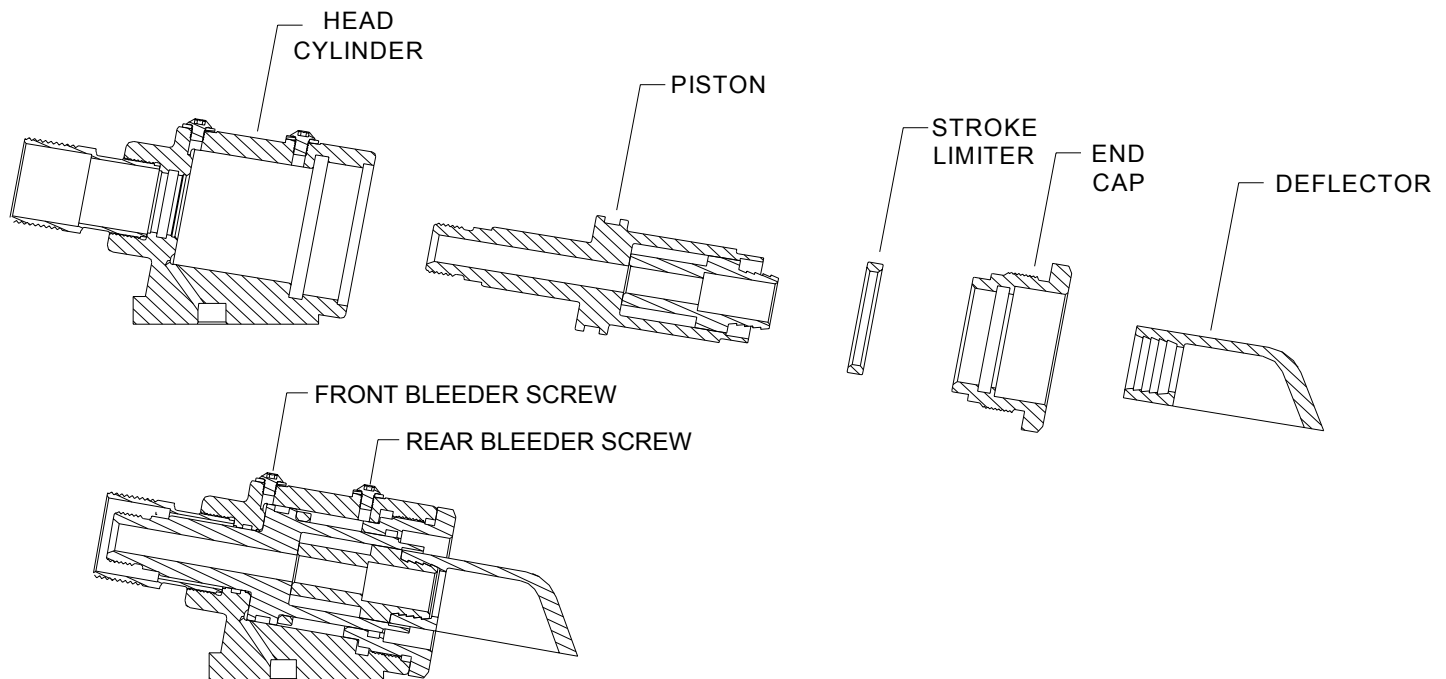

1. Disconnect air from tool.
2. Remove rear bleeder screw. CAUTION: Rear bleeder screw may be under pressure.
3. Remove deflector and end cap. CAUTION: Pour hydraulic fluid into a container.
4. Slide stroke limiter over rear piston.
5. Tighten end cap onto head cylinder and re-attach deflector. See torque spec.
6. Attach 4 oz. Bottle assembly (745163) to rear hole. Squeeze bottle gently until no air rises onto bottle.
7. With front screw and seal tightened to 35-40 inch pounds, and the 4 oz. bottle attached to rear hole, connect tool to air with the pressure being set at 40-50 psi.
8. Cycle tool 10 times, holding trigger down for 5 seconds and releasing the trigger for 5 seconds.
9. Depress trigger and hold until piston is in its full rear position. While still holding trigger, disconnect air supply.
10. Refer to "Filling and Bleeding Instructions" page 5 and check dimension 'B' to ensure tool is obtaining proper strike.
11. If tool obtains proper stroke remove 4 oz. bottle assembly from rear hole and replace screw.

SELECTION CHART FOR GB756

FASTENER	DIA.	STRAIGHT		**RIGHT ANGLE	*OFFSET	
ASP® 2 ASP & ASP PF ASP FF & ASP F ASP-LC and MAF	13/64 17/64 21/64	ASP06-745C-23 ASP08-745C-23 ASP10-755-23	ASP06-745C-48 ASP08-745C-48 ASP10-755-48	**ASP06-751B-54RA	ASP06-204D-27OS ASP08-204D-27OS ASP10-204D-27OS	ASP06-204D-37OS ASP08-204D-37OS ASP10-204D-37OS
BOM® AVBOLT®	1/4 5/16 3/8	BOM08-755-23 BOM10-756-26 BOM12-756-26				
COMMERCIAL LOCKBOLTS C6L® AVDELOK®	3/16 1/4 5/16 3/8	NAS06-745B-12 NAS06-755-23 NAS08-745B-12 NAS08-755-23 LB10-745C-26 LB12-756-26	NAS06-755-48 NAS08-755-48 NAS10-756-48 NAS12-756-48		NAS06-204C-25OS NAS06-204C-34OS NAS08-204C-25OS NAS08-204C-30OS NAS08-205A-31 NAS10-205A-31 NAS12-205A-31	NAS06-204C-30OS NAS08-204C-30OS NAS08-204C-34OS
CONTAINER BOLT	3/8	HT12-745B-28				
FLOOR BOLT	5/16	FT10-745B-26				
LGP® LOCKBOLT	5/32	LGP05-745B-12 LGP05-755-48	LGP05-755-23		LGP05-204C-25OS LGP05-204C-34OS	LGP05-204C-30OS
LGPL2SC-V BACB30VM LGPL18SC-V BACB30XT LGPL4SC-V ABS0548 LGPL2SP-V BACB30VN LGPL4SP-V A SNA2392 LGPL8SC-V BACB30WD LGPL9SC-V BACB30WB LGPL9SP-V BACB30VY	3/16 1/4 5/16 3/8	LGP06-745B-12 LGP06-755-48 LGP08-745B-12 LGP08-755-48 LGP10-745B-12 LGP10-756-48 LGP12-745B-12 LGP12-756-48	LGP06-755-23 LGP08-755-23 LGP10-756-26 LGP12-756-26		LGP06-204C-25OS LGP06-204C-34OS LGP08-204C-25OS LGP08-204C-34OS LGP10-205A-31 LGP12-205A-31	LGP06-204C-30OS LGP08-204C-30OS LGP08-205A-31
NAS and GP® SHEAR/TENSION LOCKBOLTS	5/32 3/16 1/4 5/16 3/8 3/8	NASS05-745B-12 NASS05-755-23 NASS05-755-48 NAS06-745B-12 NAS06-755-48 NAS08-745B-12 NAS08-755-48 NAS10-745B-12 NAS10-756-48 NAS12-745B-12 NAS12-745B-12 NAS12-756-48	NAST05-745B-12 NAST05-755-23 NAST05-755-48 NAS06-755-23 NAS08-755B-23 NAS10-756-26 NAS12-745B-23 NAS12-756-26		NASS05-204C-25OS NASS05-204C-30OS NASS05-204C-34OS NAS06-204C-25OS NAS06-204C-34OS NAS08-204C-25 NAS08-204C-34 NAS10-205A-31 NAS12-205A-31 NAS12-205A-31	NAST05-204C-20OS NAST05-204C-30OS NAST05-204C-34OS NAS06-204C-30OS NAS08-204C-30 NAS08-205A-31
MULTI-GRIP LOCKBOLT MAGNA-GRIP® and MAXLOK®	3/16 1/4 5/16 3/8	MG06-745-48 MG08-745-48 MG10-756-28 MG12-756-28				
MULTI-GRIP STRUCTURAL BLIND RIVET	5/16 3/8	MGL10-353-28 MGL12-353C-28				
OVERSIZE STRUCTURAL RIVET	1/4 5/16 3/8	OS08-353A-48 OS10-756-26 OS12-756-26	OS10-756-48 OS12-756-48			
BLIND BOLT (SINGLE ACTION) WITH OR W/OUT DRIVE WASHER	5/32 3/16 1/4 5/16 3/8	SB05-745C-23 SB06-745C-23 SB08-755-23 SB10-756-28 SB12-756-28	SB05-745C-48 SB06-745C-48 SB08-755-48 SB10-756-48 SB12-756-48	**SB05-751B-54RA **SB06-751B-54RA ***SB08-713A-58RA	SB05-204D-27OS SB06-204D-27OS SB08-204D-27OS SB08-205-35 SB10-205A-35 SB12-205A-35	SB05-204D-37OS SB06-204D-37OS SB08-204D-37OS

ASP®, BOM®, LGP®, C6L®, GP®, AND MAGNA-GRIP® ARE REGISTERED TRADEMARKS OF ALCOA INC. AVBOLT®, AVDELOK®, AND MAXLOK® ARE REGISTERED TRADEMARKS OF AVDEL UK LIMITED.

GAGE BILT CERTIFIES THE GB756 WILL INSTALL THE ABOVE FASTENERS

*ALL OFFSET 204 SERIES NOSES REQUIRE 353204 A DAPTER WITH 756152 STROKE LIMITER.
*ALL OFFSET 205 SERIES NOSES REQUIRE 353205 A DAPTER WITH 756153 STROKE LIMITER.
** -54RA RIGHT ANGLE SERIES NOSES REQUIRE 745751 A DAPTER WITH 756155 STROKE LIMITER.
*** -58RA RIGHT ANGLE NOSES REQUIRE 745751 WITH 756152 STROKE LIMITER.

NOTE: THE LAST 2 DIGITS OF THE NOSE ASSEMBLY REPRESENTS THE LENGTH THE NOSE
EXTENDS FROM THE TOOL I.E. -20 = 2.0 INCHES

12/11



**GAGE BILT ALSO SUPPLIES PIN & COLLAR SWAGE INSPECTION
GAGES TO CERTIFY CORRECT SWAGE INSTALLATION.**



GAGE BILT



DECLARATION OF CONFORMITY

WE DECLARE THAT THE EQUIPMENT SPECIFIED HEREIN
CONFORMS TO THE FOLLOWING STANDARDS AND DIRECTIVES.

EN292 part 1 and part 2
ISO 8662 part 1
ISO 3744

COUNCIL DIRECTIVE: 89/392/EEC, 91/368/EEC
93/44/EEC, 93/68/EEC

EQUIPMENT DESCRIPTION:
GB756 FASTENER INSTALLATION TOOL

MANUFACTURER:
GAGE BILT Inc.

SIGNATURE: 

NAME: BRUCE T. GODFREY
CHAIRMAN
CLINTON TWP., MI U.S.A.
JUNE 2010

WARRANTY

Seller warrants that all goods covered by this catalog will conform to applicable specifications and will replace or repair, F.O.B. our plant, any goods providing defective from faulty workmanship, or material, for 90 days from date of shipment.

Said warranty to remain in effect if, and only if, such goods are used in accordance with all instructions as to maintenance, operation and use, set forth in manuals and instruction sheets furnished by seller.

Sellers obligation under this warranty shall be limited to the repair or rework of the goods supplied or replacement thereof, at Seller's option, and in no case is to exceed the invoice value of said goods. Under no circumstances will the seller be liable for incidental or consequential damages or for damages incurred by the buyer or subsequent user in repairing or replacing defective goods or if the goods covered by this warranty are reworked or subjected to any type of additional processing.

This warranty is void if Seller is not notified in writing of any rejections or defects within 90 days after the receipt of the material by the customer.

THIS WARRANTY IS MADE IN LIEU OF ALL OTHER WARRANTIES EXPRESSED OR IMPLIED, INCLUDING MERCHANTABILITY.