

GBP4801B/GBP4801B(A)

HYDRAULIC INSTALLATION TOOL

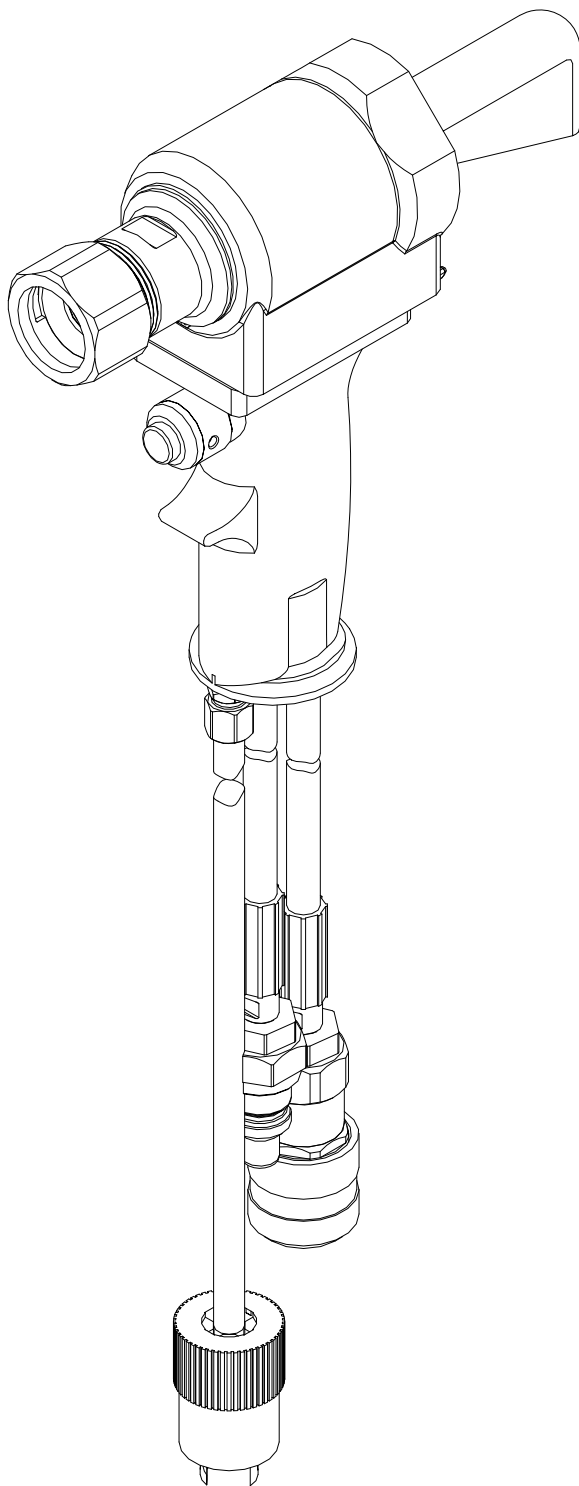

GAGE BILT
MADE IN U.S.A.

GAGE BILT PRODUCTS CORP.
14500 Barber Drive
Warren, MI. 48093
e-mail: gbp@ameritech.net / www.gbp.thomasregister.com
(810) 771-7664
(810) 771-2665 Fax

TABLE OF CONTENTS

<u>Description</u>	<u>Page</u>
Warnings.....	3
Description, Operation and Maintenance.....	4
Parts Lists.....	5-6
Trouble Shooting and Overhaul.....	7
Nose Assembly Selection Chart.....	8

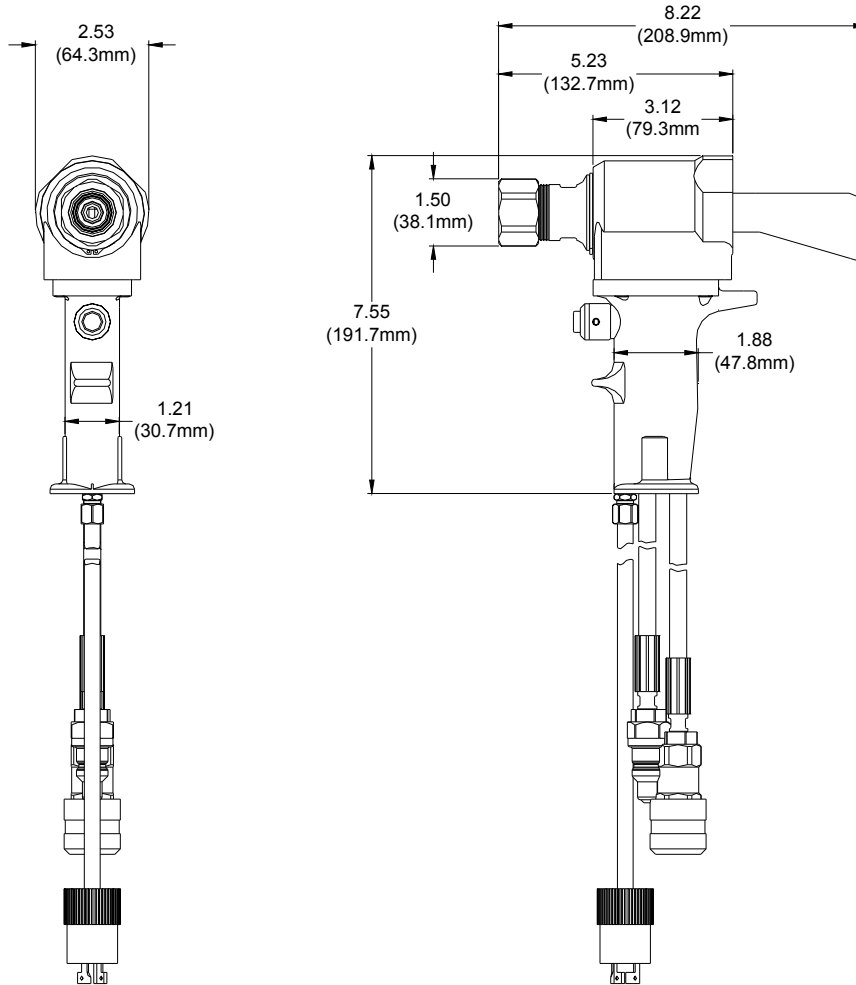

SPECIFICATIONS

Weight	- 8 lbs.
Hyd. Pressure Req'd.	- 5600-6000 psi PULL - 2200-2400 psi RETURN
Hyd. Power Source	- GBP940 Powerunit or equivalent.
Hydraulic Fluid	- Fire resistant hydraulic fluid conforming with OSHA regulation 1926.302.
Setting Stroke	- 1.000"
Rated Pull Load	- 11,000 lbs.



NOTE:

PLEASE READ THIS MANUAL BEFORE SERVICING OR USING THIS TOOL. COMPLETE WITH WARNINGS AND CAUTIONS TO PREVENT SEVERE PERSONAL INJURY OR DAMAGE THE TOOL.



CAUTION:

GAGE BILT TOOLS ARE APPROVED TO INSTALL HUCK®, AVDEL®, CHERRY®, POP® AND OTHER FASTENERS WHEN USED BY PERSONS WITH SPECIFIC TRAINING OF BLIND RIVET AND LOCKBOLT INSTALLATION EQUIPMENT.

WARNING

Do not pull fastener unless it is placed in an assembly, pin will eject forcibly when pintail breaks off. Severe personal injury may result.

WARNING

Always disconnect tool from powerunit before performing any maintenance to any tool or nose assembly. Insure that all connections are proper and there are no visible leaks from tool or hoses before connecting to power.

WARNING

When operating installation equipment always wear approved eye protection. Do not look in front of nose assembly or rear of tool when installing fastener.

CAUTION

Insure that nose assembly and tip are properly matched for the fastener being installed.

WARNING

Installation of fasteners may exceed acceptable noise levels. Use approved hearing protection.

WARNING

Be sure there is adequate clearance for tool and operator's hands before proceeding. Keep fingers clear of any moving parts. Keep fingers clear from fasteners and installed materials. Severe personal injury may result.

WARNING

Do not remove and add hoses without using flats on 750128 tube assembly. Severe personal injury could result.

WARNING

Hydraulic power units that deliver high pressure for the "PULL" and "RETURN" and are not equipped with relief valves are specifically not recommended and may be dangerous.

CAUTION

Keep Nose Assemblies clean and free of chips and debris.

DESCRIPTION

The GBP4801B is a hydraulic installation tool designed specifically for the efficient installation of a wide range of blind, lockbolt and Magna-Grip fasteners thru 3/8" diameter. It weighs just under 8 lbs. and can be operated in any position with one hand. It has a 1.000" rivet setting stroke and a rated pull load of 11,000 pounds.

The GBP4801B installation tool operates on hydraulic pressure developed by the GBP940 powerunit set at 5600 psi maximum PULL pressure and 2400 psi maximum RETURN pressure. The tool comes equipped with 12' hoses and electric cord kit complete with quick disconnects. The GBP4801B(A) installation tool operates on hydraulic pressure developed by the GBP910 Powerunit set at 5600 psi maximum PULL pressure and 2400 psi maximum RETURN pressure. The tool comes equipped with 12 feet of hydraulic hoses, and couplings.

NOSE ASSEMBLIES ARE NOT FURNISHED WITH THIS RIVETER AND MUST BE ORDERED SEPARATELY.

OPERATION

When the tool is connected to a powerunit, operation is controlled by a button in the handle. When the button is depressed, a directional valve in the powerunit directs fluid to the front side of the piston forcing it and the nose assembly collet rearward. This action causes the jaws to clamp onto the fastener pintail and pull the sheets together. The anvil is forced forward, swaging the collar into locking grooves of the fastener. Further force breaks the pintail off, approximately flush with the collar.

When the button is released the directional valve reverses fluid flow to the back of the piston and pushes the nose assembly off of the swaged fastener. The pintail ejector hydraulically pushes the spent pintail out of the nose assembly.

MAINTENANCE

The performance of any tool depends upon good maintenance practices. Following these minimal requirements for service and care will extend the life of your tool.

- *Only use a hydraulic power source equipped with relief valves and pressures set within specified limits.
- *Keep hydraulic system free of dirt. Avoid letting couplers contact a dirty floor.
- *Do not use as a hammer to force fasteners into holes or otherwise abuse tool.
- *Proper care by operators is necessary in maintaining full productivity and reducing downtime.

WARNING

Be sure Powerunit is disconnected before cleaning, or when replacing worn or damaged components. Severe personal injury may occur if power source is not disconnected.

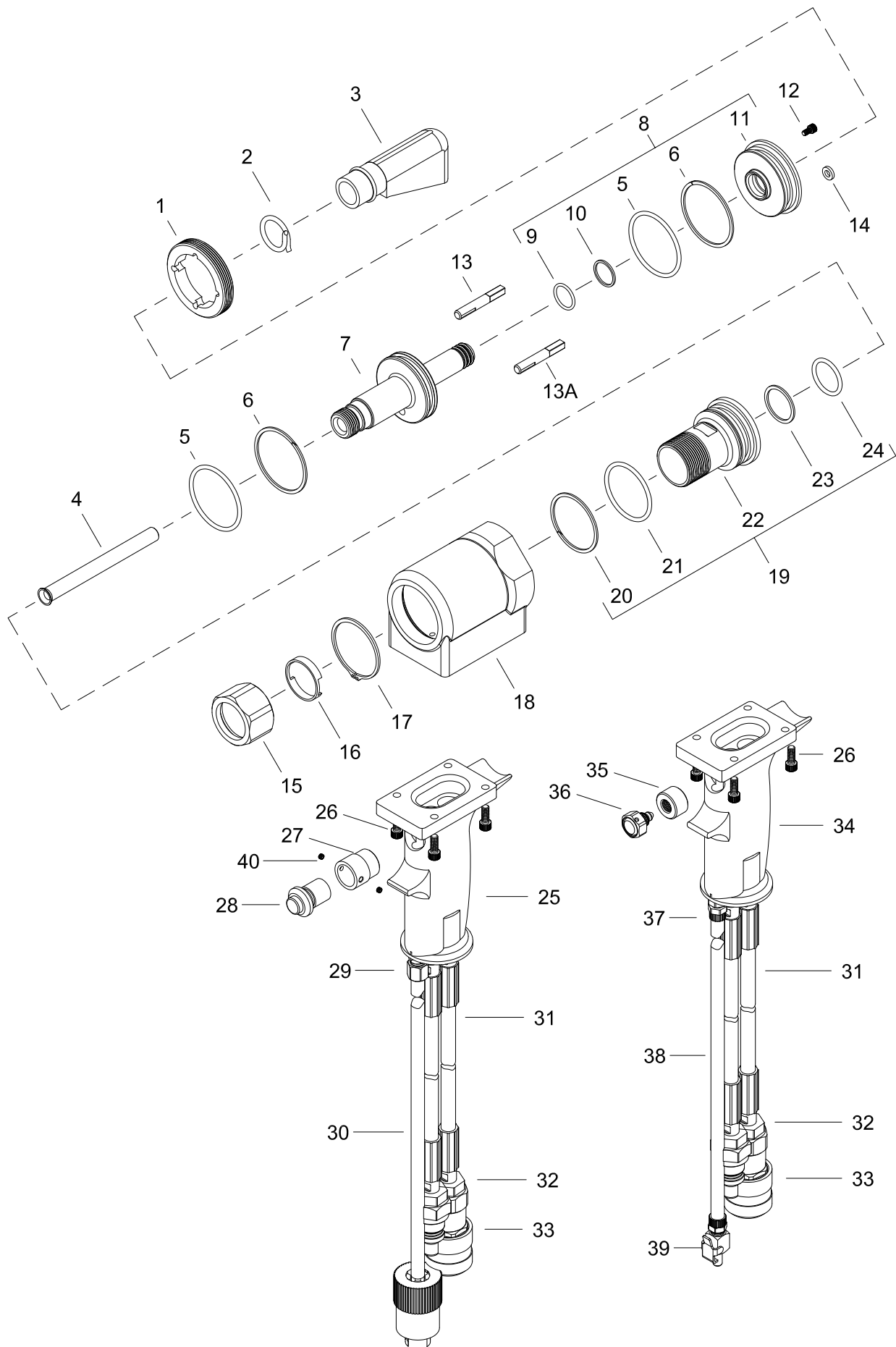

GBP4801B/GBP4801B(A) Parts List

Ref. No.	Part Number	Description	Qty.
1	480123	Locking Ring	1
2	480121	Hose Clamp	1
3	704113	Deflector	1
4	480101	Pintail Tube	1
5*	404458	O'Ring	2
6*	401122	Back-Up Ring	2
7	480110	Piston Assembly (Inc.5-6)	1
8	480113	Cylinder Cap Assembly (5,6 & 9-11)	1
9*	404412	O'Ring	1
10*	401088	Back-Up Ring	1
11	480112	Cylinder Cap	1
12*	401198	Socket Head Cap Screw	1
13	480118	Relief Valve (GBP4801B)	1
13A	480122	Relief Valve (GBP4801B(A))	1
14	480119	Locator	1
15	480124	Nut	1
16	480125	Retaining Nut Stop	1
17	401018	Retaining Ring	1
18	480203	Cylinder Assembly (Inc. 26)	1
19	480105	Nose Adapter Assembly (Inc.20-24)	1
20*	401119	Back-Up Ring	1
21*	404455	O'Ring	1
22	480106	Nose Adapter	1
23*	401109	Back-Up Ring	1
24*	404445	O'Ring	1
25	480226	Handle Assembly (Inc.27)	1
26*	400061	Socket Head Cap Screw	4
27	480132	Trigger Body	1
28	240126	Electric Trigger	1
29	480341	Strain Relief	1
30	480228	Control Cord Assembly	1
31	206119	Hydraulic Hose Assembly	2
32	403431	Reducer Bushing	2
33	585037	Hydraulic Coupling Assembly	1
34**	480227	Handle Assembly (Inc.35)	1
35**	480342	Trigger Body	1
36**	704130	Trigger Assembly	1
37**	A-89	Strain Relief	1
38**	208140	Air Tubing	1
39**	208127	Quick Disconnect	1
40*	480343	Flat Point Socket Set Screw	2

*Service Kit 480001 (GBP4801B) and 480002 (GBP4801B(A)) contains a complete set of O'Rings, Back-Up Ring and Screws. These items should be kept on hand at all times.

**Ref No. 13A, 34-39 are included in GBP4801B(A) only.

TROUBLE SHOOTING

Providing all maintenance conditions have been met, follow this systematic approach to diagnosis.

1. NO OPERATION WHEN TRIGGER IS DEPRESSED

- a.) Check Powerunit power source.
- b.) Control cord may be loose or damaged.
- c.) Faulty trigger. Replace.
- d.) Check hydraulic couplings; repair or replace.

2. SLOW OR PARTIAL OPERATION WHEN TRIGGER IS DEPRESSED

- a.) Low hydraulic pressure. Check powerunit, adjust.
- b.) Cylinder Piston O'Ring (5) could be worn or damaged. Replace.
- c.) Excessive wear or scoring on moving parts. Check and replace faulty parts.

3. TOOL OPERATES IN REVERSE

- a.) Tool stops in back position. Hydraulic hoses are reversed. Correct.

4. HYDRAULIC OIL OVERHEATS

- a.) Powerunit motor rotation reversed. Electrical connections reversed. See powerunit instruction manual.
- b.) Restrictions in either hydraulic lines, hoses or couplings. Check and tighten, clean or replace.

5. OIL LEAKAGE

- a.) Hydraulic oil leaks from connections. Tighten threaded connections. Do not use teflon tape.
- b.) Oil leaks from tool. Determine source of leak and replace worn or defective O'Rings and back-up rings.

6. PINTAIL GROOVES STRIPPED DURING PULL STROKE

- a.) Nose Assembly must be pushed onto fastener fully.
- b.) Chips may have collected in chuck jaws. Disassemble nose assembly, clean jaws in mineral spirits using a sharp pointed object.
- c.) Chuck jaws may be worn or damaged. Replace.
- d.) Pintail too short for jaws to properly grip. Select proper grip length fastener.
- e.) Excessive gap between sheets. Reduce gap before attempting to install fastener.

7. NOSE ASSEMBLY WON'T ACCEPT FASTENER PINTAIL

- a.) Spent fastener stem may be jammed in pulling head. Disassemble and check for worn or broken parts in nose assembly. Replace defective parts and clean before reassembling.

OVERHAUL

If a tool is performing poorly or leaking badly, a complete overhaul may be necessary. Service Kit 480001 (GBP4801B) or 480002 (GBP4801B(A)) contains a complete set of O'Rings, back-up rings and screws.

Perform overhaul in a clean, well lit area using care not to scratch or nick any smooth surface that comes in contact with an O'Ring. Use of lubriplate (GBP Part no. 402723) or another lubricant is recommended during reassembly to prevent tearing or distorting of O'Rings.

Disconnect hydraulic hoses and electrical cord or air line from powerunit. Remove couplers (33) from hoses and drain. Push piston (7) back into cylinder (18) to empty all fluid from tool. Remove clamp (2) and deflector (3) from back end of piston and push piston back to the front of cylinder. Unscrew retaining nut (15), remove stop (16) and retaining ring (17) using Truarc Pilers.

Unscrew socket head cap screw (12) from locking ring (1) using a spanner wrench to remove locking ring. Push piston back until cylinder cap (11) and locator (14) fall out of cylinder. Push adapter (22) back and guide it and the piston (7) out the rear of cylinder. Slide piston out of adapter and remove relief valve (13) and pintail tube (4) from piston. Using a small blunt object, remove O'Rings and back-up rings from components.

Remove strain relief (29 or 37) from handle (25 or 34). Lift out all electrical (28 & 30) or air line (38 & 39) components as an assembly. Remove socket head cap screws (26) and unscrew hydraulic hoses from cylinder.

Clean parts in mineral spirits or other O'Ring compatible solvent being sure to clean O'Ring grooves. Inspect components for scoring, excessive wear or damage.

Reassembly sequence is opposite of disassembly. Be sure relative positions of O'Rings and back-up rings are as shown in exploded view and parts list. Relief valve must be installed with four flats towards the rear and must enter notch in the rear of adapter. Coat hose fitting threads with a non-hardening teflon thread compound such as Slicite (GBP part no. 403237). DO NOT USE TEFLON TAPE.

GBP4801B SELECTION CHART

FASTENER	DIA.	STRAIGHT		*OFFSET	
2 ASP & ASP PF ASP FF & ASP F ASP-LC	13/64 17/64 21/64	ASP06-745B-23 ASP08-745B-23 ASP10-755-23	ASP06-745B-48 ASP08-745B-48 ASP10-755-48	ASP06-204C-27OS ASP08-204C-27OS ASP10-204C-27OS	ASP06-204C-37OS ASP08-204C-37OS ASP10-204C-37OS
BLIND OVERSIZE MANDREL	1/4 5/16 3/8	BOM08-745C-23 BOM10-756-26 BOM12-756-26			
COMMERCIAL LOCKBOLTS C&L ADVELOK	3/16 1/4 5/16 3/8	NAS06-745B-12 NAS06-755-23 NAS08-745B-12 NAS08-745B-23 LB10-745C-26 LB12-756-26	NAS06-755-48 NAS08-745B-48 NAS10-756-48 NAS12-756-48	NAS06-204B-25OS NAS06-204B-34OS NAS08-204B-25OS NAS08-205A-31 NAS10-205A-31 NAS12-205A-31	NAS06-204B-30OS NAS08-204B-30OS NAS08-204B-34OS
CONTAINER BOLT	3/8	HT12-745B-28			
FLOOR BOLT	5/16	FT10-745B-26			
LIGHTWEIGHT GROOVE PROPORTION LOCKBOLTS	5/32 3/16 1/4 5/16 3/8	LGP05-745B-12 LGP05-755-48 LGP06-745B-12 LGP06-755-48 LGP08-745B-12 LGP08-745B-48 LGP10-745B-12 LGP10-756-48 LGP12-745B-12 LGP12-756-48	LGP05-755-23 LGP06-755-23 LGP08-745B-23 LGP10-756-26 LGP12-756-26	LGP05-204B-25OS LGP05-204B-34OS LGP06-204B-25OS LGP06-204B-34OS LGP08-204B-25OS LGP08-204B-34OS LGP10-205A-31	LGP05-204B-30OS LGP06-204B-30OS LGP08-204B-30OS LGP08-205A-31
LOCKBOLT NAS SHEAR PULL TYPE NAS TENSION PULL TYPE & GROOVE PORPORTION NASS = NAS SHEAR NAST = NAS TENSION	5/32 3/16 1/4 5/16 3/8	NASS05-745B-12 NASS05-755-23 NASS05-755-48 NAS06-745B-12 NAS06-755-48 NAS08-745B-12 NAS08-745B-48 NAS10-745B-12 NAS10-756-48 NAS12-745B-12 NAS12-756-48	NAST05-745B-12 NAST05-755-23 NAST05-755-48 NAS06-755-23 NAS08-745B-23 NAS10-756-26 NAS12-756-26	NASS05-204B-25OS NASS05-204B-30OS NASS05-204B-34OS NAS06-204B-25OS NAS06-204B-34OS NAS08-204B-25 NAS08-204B-34 NAS10-205A-31 NAS12-205A-31	NAST05-204B-20OS NAST05-204B-30OS NAST05-204B-34OS NAS06-204B-30OS NAS08-204B-30 NAS08-205A-31
MULTI-GRIP LOCKBOLT	3/16 1/4 5/16 3/8	MG06-745-48 MG08-745-48 MG10-756-28 MG12-756-28			
MULTI-GRIP STRUCTURAL BLIND RIVET	3/8	MGL12-353C-28			
OVERSIZE STRUCTURAL RIVET	1/4 5/16 3/8	OS08-353A-48 OS10-756-26 OS12-756-26	OS10-756-48 OS12-756-48		
SINGLE ACTION BLIND BOLT MS21140S & MS21140U MS21141S & MS21141U MS90353S & MS90353U MS90354S & MS90354U	5/32 3/16 1/4 5/16 3/8	SB05-745B-23 SB06-745B-23 SB08-755-23 SB10-756-28 SB12-756-28	SB05-745B-48 SB06-745B-48 SB08-755-48 SB10-756-48 SB12-756-48	SB05-204C-27OS SB06-204C-27OS SB08-204C-27OS SB10-205A-35 SB12-205A-35	SB05-204C-37OS SB06-204C-37OS SB08-204C-37OS

THE GAGE BILT GBP4801B/4801B(A) TOOL IS APPROVED TO INSTALL THE ABOVE FASTENERS.

*ALL OFFSET 204 SERIES NOSES REQUIRE 353204 ADAPTER WITH 480152 STROKE LIMITER,
& ALL OFFSET 205 SERIES NOSES REQUIRE 353205 ADAPTER WITH 480153 STROKE LIMITER.

NOTE: THE LAST 2 DIGITS OF THE NOSE ASSEMBLY REPRESENTS THE LENGTH THE NOSE
EXTENDS FROM THE TOOL I.E. -20 = 2.0 INCHES

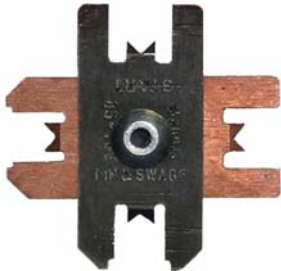

**GAGE BILT ALSO SUPPLIES PIN & COLLAR SWAGE INSPECTION
GAGES TO CERTIFY CORRECT SWAGE INSTALLATION.**



WARRANTY

Seller warrants that all goods covered by this catalog will conform to applicable specifications and will replace, or repair, F.O.B. our plant, any goods providing defective from faulty workmanship, or material, for 90 days from date of shipment.

Said warranty to remain in effect if and only if such goods are used in accordance with all instructions as to maintenance, operation, and use set forth in manuals and instruction sheets furnished by seller.

Sellers obligation under this warranty shall be limited to the repair or rework of the goods supplied or replacement thereof, at Seller's option, and in no case is to exceed the invoice value of said goods. Under no circumstances will seller be liable for incidental or consequential damages or for damages incurred by the buyer or subsequent user in repairing or replacing defective goods or if the goods covered by this warranty are reworked or subjected to any type of additional processing.

This warranty is void if Seller is not notified in writing of any rejections or defects within 90 days after the receipt of the material by the customer.

**THIS WARRANTY IS MADE IN LIEU OF ALL OTHER WARRANTIES,
EXPRESS OR IMPLIED, INCLUDING MERCHANTABILITY.**