

GBP731

INSTALLATION TOOL

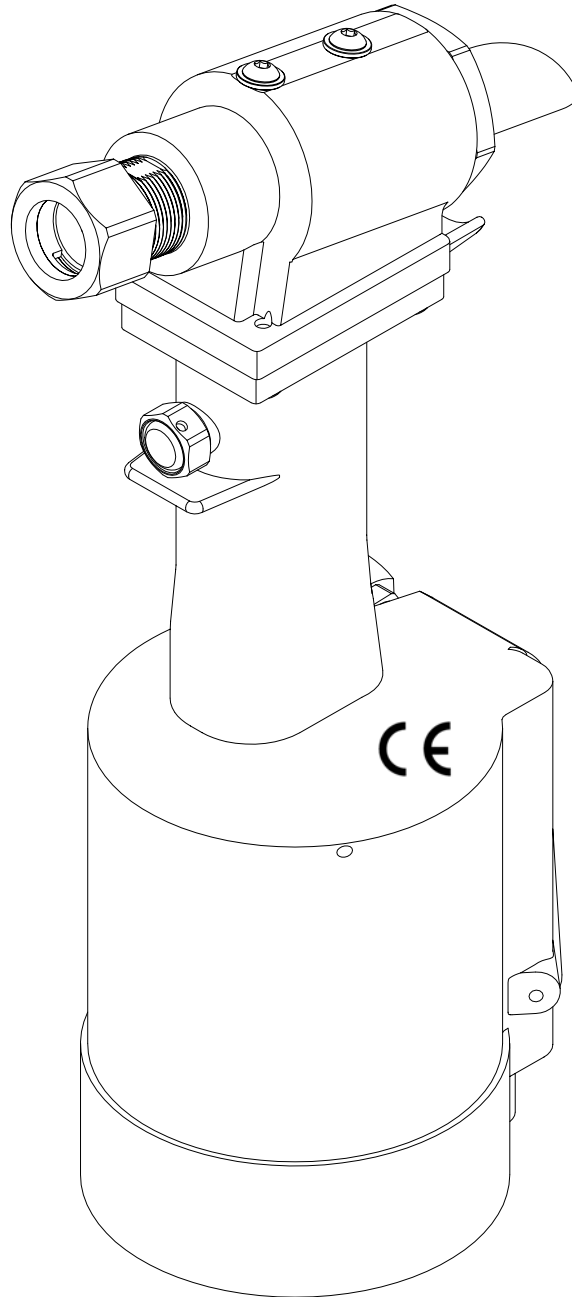

GAGE BILT
MADE IN U.S.A.

GAGE BILT PRODUCTS CORP.
44766 Centre Court (586) 226-1500
Clinton Twp. MI 48038 (586) 226-1505 Fax
e-mail: solutions@gagebilt.com / www.gagebilt.com

TABLE OF CONTENTS

<u>Description</u>	<u>Page</u>
Warnings.....	3
Description, Operation and Maintenance.....	4
Filling & Bleeding	5
Trouble Shooting.....	6
Overhaul, Disassembly and Parts Lists.....	7-8
Nose Assembly Selection Chart.....	9
EU Conformity and Warranty.....	10

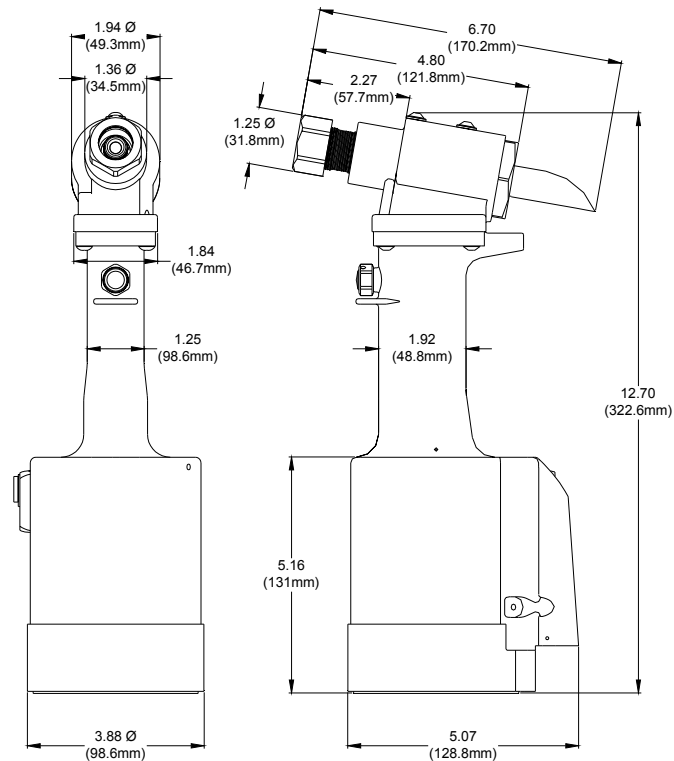

SPECIFICATIONS

- Hand Held Weight** - 5.75 lbs.
- Air pressure req'd** - 90-120 p.s.i.
- Air consumption** - .16 SCF/cycle (4.53 L/cycle)
- Hydraulic fluid** - Automatic Transmission Fluid, Dextron III, or equivalent.
- Setting stroke** - .600"
- Rated pull load** - 4,800 lbs.
- Noise level** - 78.4 dB (A)
- Vibration** - less than 2.5 M/S²



NOTE:

PLEASE READ THIS MANUAL BEFORE SERVICING OR USING THIS TOOL. COMPLETE WITH WARNINGS AND CAUTIONS TO PREVENT SEVERE PERSONAL INJURY OR DAMAGE THE TOOL.



CAUTION:

GAGE BILT TOOLS ARE APPROVED TO INSTALL HUCK®, AVDEL®, CHERRY®, POP® AND OTHER FASTENERS WHEN USED BY PERSONS WITH SPECIFIC TRAINING OF BLIND RIVET AND LOCKBOLT INSTALLATION EQUIPMENT.

WARNING

Do not pull fastener unless it is placed in an assembly, pin will eject forcibly when pintail breaks off. Severe personal injury may result.

WARNING

Do not operate without Stat-O-Seal (S572) and cap screw (402482). Pressurized hydraulic fluid may cause severe personal injury.

WARNING

When operating installation equipment always wear approved eye protection. Do not look in front of nose assembly or rear of tool when installing fastener.

WARNING

Always disconnect tool from power before performing any maintenance to any tool or nose assembly. Insure that all connections are proper and there are no visible leaks from tool or hoses before connecting to power.

WARNING

Do not operate if deflector, bottle, catcher bag or vacuum tube is removed or damaged, broken pintails may eject forcibly from rear of tool. Severe personal injury may result.

CAUTION

Insure that nose assembly and tip are properly matched for the fastener being installed.

WARNING

Installation of fasteners may exceed acceptable noise levels. Use approved hearing protection.

WARNING

Be sure there is adequate clearance for tool and operator's hands before proceeding. Keep fingers clear of any moving parts. Keep fingers clear from fasteners and installed materials. Severe personal injury may result.

CAUTION

Keep Nose Assemblies clean and free of chips and debris.

DESCRIPTION

Covered under Patent No. 5,485,727

The GBP731 is a pneumatic-hydraulic tool designed specifically for the efficient installation of a wide range of blind rivets and lockbolts. It weighs 5.75 lbs. and can be operated in any position with one hand. It has a .600" rivet setting stroke and a rated pull load of 4800 pounds with 90 psi air pressure at the air inlet.

The GBP731 riveter operates on a wide range of air pressure, with 90 to 100 psi providing the maximum efficiency. At 90 lbs. air pressure, the GBP731 does not exceed 85 db (A) and consumes 3.9 cfm at 20 cycles per minute.

The air inlet is provided with 1/4-18 female pipe threads for accepting the user's air hose fitting.

Nose Assemblies that were designed for the Model 352 Installation Tool mount directly on the GBP731 without the use of an adapter.

NOSE ASSEMBLIES ARE NOT FURNISHED WITH THIS TOOL AND MUST BE ORDERED SEPARATELY (SEE PAGE 8).

MAINTENANCE

The performance of any tool depends upon good maintenance practices. Following these minimal requirements for service and care will extend the life of your tool.

*Only use an air supply set at 90-120 lbs. equipped with a filter-regulator to prevent wear.

*The tool will eventually lose some hydraulic oil. Keep the hydraulic system full and free of air by using the air bleeder (745163) on a regular basis.

*Proper care by operator is necessary in maintaining full productivity and reducing downtime. Read all applicable tool manuals and nose assembly data sheets prior to operating tools.

*Keep nose assemblies, especially jaws, clean and free of chips and debris.

*For a complete overhaul, tool kit GBP730CTK is recommended.

TORQUE SPECIFICATIONS

Button Head Cap Screws (A-928) = 40 inch lbs.

Packing Plug (704118) = 45 foot lbs.

Flexlock Nut (400559) = 40 inch lbs.

WARNING

This tool incorporates a patented hydraulic relief valve. When overhauling tool, o'ring (400777), retaining ring (400934) and spring (50617) must be replaced. Failure to do so could result in **SEVERE PERSONAL INJURY!**

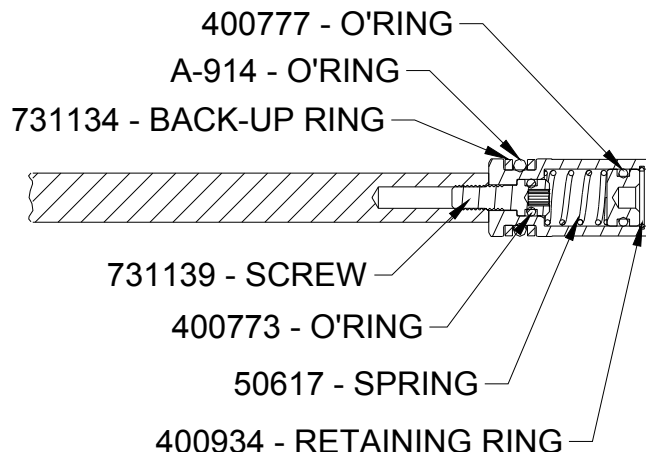

FILLING AND BLEEDING INSTRUCTIONS

WARNING:

Do not cycle tool without screws or bleeder bottle installed in tool head. Severe personal injury may occur.

To replace a small amount of oil in the tool cycle tool to rear position disconnect air and follow steps 6-12 below.

Should it become necessary to completely refill the tool (as would be required after tool has been dismantled and reassembled), take the following steps.

1. Ensure air piston is at the full bottom of stroke by pushing power piston rod down.
2. Fill power cylinder and oil passage (hole for S832 o'ring) to the top, being careful not to get oil into the air passage.
3. Place gasket (745124) and o'ring (S832) on top of the handle.
4. Push head piston to rear of head cylinder until it stops. (DIM "B")
5. Press head cylinder down on top of handle, being careful not to tear o'ring on top of power cylinder, install screws and tighten evenly, to 40 inch lbs.
6. Remove front screw and seal from top of head. Attach 4oz. bottle assy (745163) making sure rear screw and seal is in place
7. Squeeze bottle gently until no air rises into bottle. (Be careful not to move head piston when filling with oil).
8. Connect tool to air. Head cylinder piston will then move to forward position. (DIM "A")
9. Remove 4oz. bottle assy. (745163), replace screw and stat-o-seal then disconnect air supply.
10. Carefully remove screw and stat-o-seal from rear hole. (**NOTE:** Rear hole could be under pressure.)
11. Attach 4oz. Bottle assy. (745163) to rear hole, squeeze bottle gently until no air rises into bottle.
12. Remove bleeder bottle and replace rear bleeder screw and seal. Connect to air.

Cycle tool 5-6 times and check stroke of .570 (see below). We recommend using a pair of dial calipers. With the trigger released check dimension (A). Holding trigger check dimension (B). Subtract dimension (A) from dimension (B). If stroke is not consistent within 1/64" (.0156) repeat steps 6-12.

CAUTION: Use CAUTION when removing screws and 4oz bottle assy. hydraulic fluid may be under pressure.

WARNING: Failure to follow these instructions carefully may result in severe personal injury.

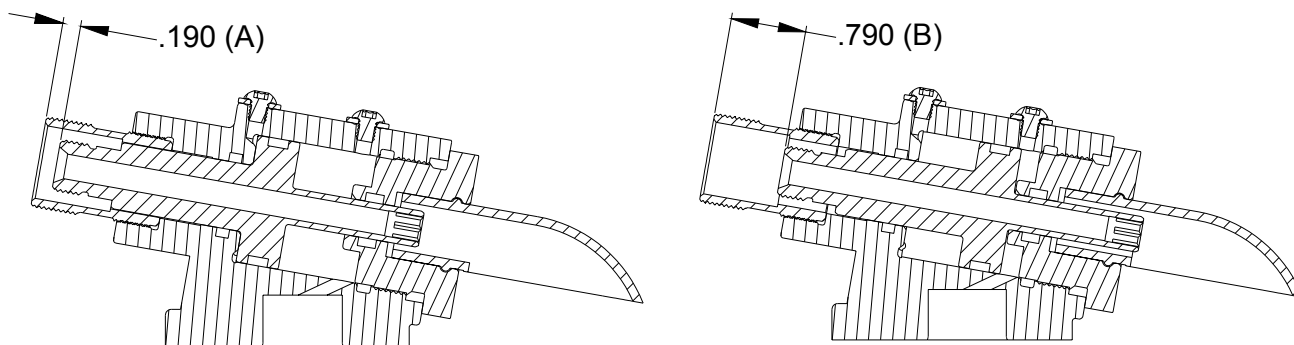

TROUBLE SHOOTING

Providing all maintenance conditions have been met, follow this systematic approach to diagnosis.

1. MORE THAN ONE PULL IS REQUIRED TO BREAK RIVET.
 - a) Tool needs to be bled. (See filling and bleeding instructions.)
 - b) Spring has fatigued, replace.
 - c) Jaws are stripped or packed with chips. Clean or replace.
 - d) Incorrect nose tip.
2. SLOW OR PARTIAL OPERATION WHEN THE TRIGGER IS DEPRESSED
 - e) Head Piston Rings (A-1044) and (401113) could be worn or damaged. Replace.
 - f) Piston Rod Rings (731134) and (A-914) could be worn or damaged. Replace.
 - g) Muffler (704146) or filter inside spool (703142) may be plugged with dirt. Clean thoroughly and back-blow with compressed air.
 - h) Hole in metering screw in valve spool (703142) may be blocked or damaged. Hole diameter should be .028". Clear and size or replace.
3. NO OPERATION WHEN TRIGGER IS DEPRESSED
 - a) Tool seized due to mechanical failure or damaged parts.
4. OIL LEAKAGE
 - a) **DO NOT OPERATE WITH OIL LEAKING FROM TOOL. HIGH PRESSURE OIL MAY CAUSE SEVERE PERSONAL INJURY.**
 - b) Any oil leaking externally should be traced to its source. An o’ring or seal that leaks should be replaced.
5. AIR BYPASS FROM VALVE HOUSING
 - a) If the spring (704141) breaks or dislodges, air will flow freely through the muffler (704146). Replace or reset. Valve spring installation tool (704162) is recommended.
 - b) Check o’rings on valve sleeve (703139), valve spool (703142), and valve plug (704145). If worn or damaged, replace. Valve sleeve removal tool (704163) is recommended.
6. FASTENER STEM JAMMED IN NOSE ASSEMBLY
 - a) Nose assembly components require service. **DISCONNECT AIR FROM TOOL**, remove the nose from the tool and disassemble. Replace worn or broken parts. Clean the surface the jaws ride on.
 - b) Stems lodged side by side in the follower. Disassemble, remove stems, and reassemble.
 - c) Incorrect follower.

OVERHAUL

The disassembly and re-assembly procedure can be accomplished by utilizing the following instructions and drawings. Use extreme care during disassembly and re-assembly not to mar or nick any smooth surface that comes in contact with seals. Before installing seals, always apply a good lubricant, such as Lubriplate, to the surfaces. It is recommended that tool kit (GBP730CTK) be used to facilitate overhaul. A complete overhaul can be achieved by the use of Service Kit 731002 which contains a complete set of o’rings, back-up rings, screws, washers and gasket.

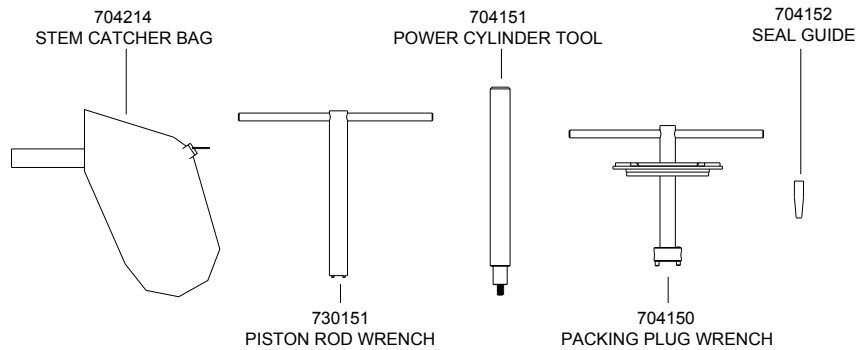

GBP730CTK Service Tool Kit

Part No.	Description
730151	Piston Rod Wrench
704150	Packing Plug Wrench
704151	Power Cylinder Tool
704152	Seal Guide
745163	Fill Bottle Assembly (Not Shown)
S1178	Valve Extractor (Not Shown)
704162	Valve Spring Installation Tool (Not Shown)
704163	Valve Sleeve Removal Tool (Not Shown)

WARNING

DEPRESS TRIGGER AND DISCONNECT FROM AIR WITH HEAD PISTON IN THE REAR POSITION BEFORE OVERHAUL. SEVERE PERSONAL INJURY MAY OCCUR IF AIR HOSE IS NOT DISCONNECTED. **USE CAUTION** WHEN FORCING PISTON ROD ASSEMBLY DOWNWARD WITH HEAD CYLINDER ASSEMBLY REMOVED, HYDRAULIC FLUID WILL EJECT FORCIBLY FROM HANDLE.

LUBRICATING AND CLEANING PROCEDURE

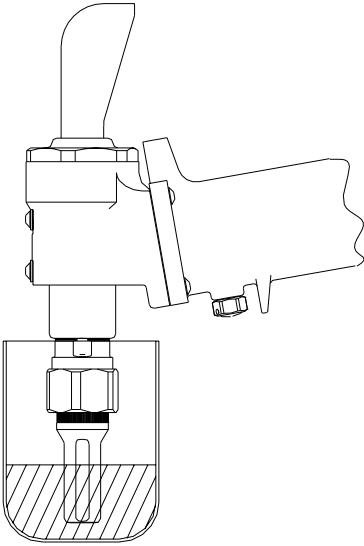

Daily cleaning and lubrication of nose assembly will greatly reduce downtime and increase life of components. Using sewing machine oil, or an equivalent cleaner/lubricant, follow instructions below.

1. Disconnect tool vacuum line (if equipped).
2. Point nose assembly into oil as shown.
3. Cycle tool 8-10 times and wipe dry.

HEAD

Remove nose assembly from tool before attempting disassembly of head assembly.

Remove end cap (731317). Push against threaded end of head piston (731211) to slide it out of head cylinder (731198). Be careful not to damage threads or cause burrs on polished piston rod surface.

The re-assembly sequence is the opposite of disassembly. (See Filling and Bleeding instructions.) Apply Loctite #242 and torque the four button-head cap screws (A-928) uniformly to 40 inch lbs. to prevent leakage around the gasket.

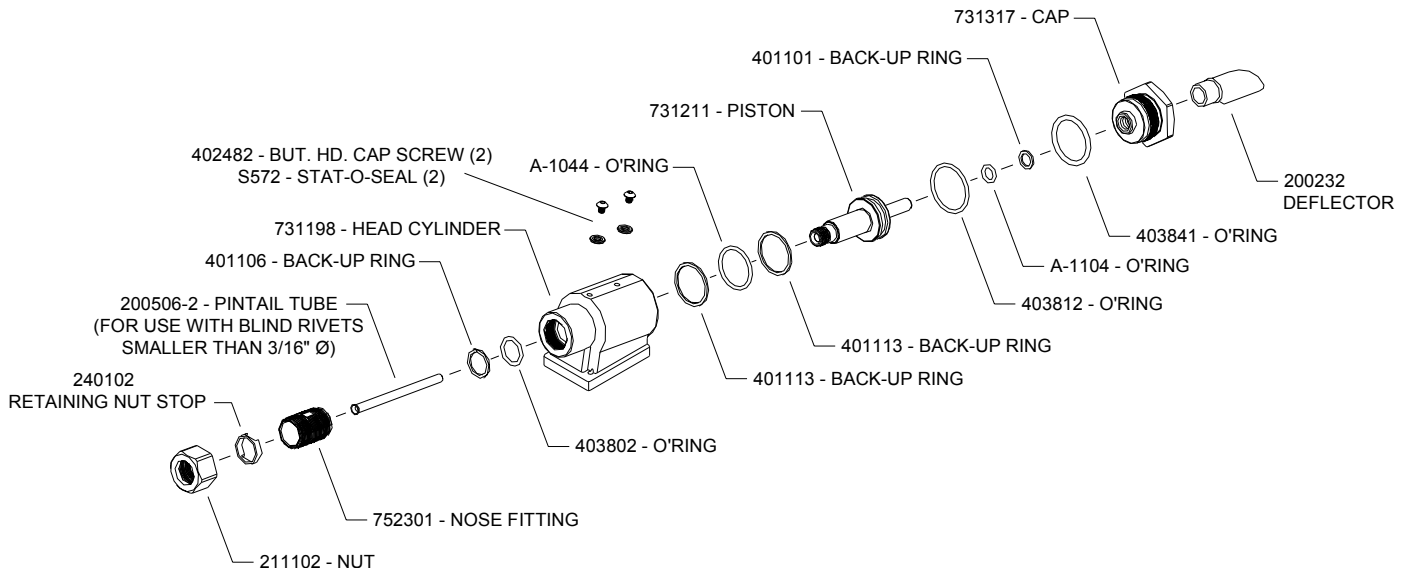

HANDLE

To inspect air cylinder bore, remove base cover (704125). Any further disassembly will require removal of the head cylinder (731198) first. For complete disassembly, start by removing base cover (704125). Next, holding tool upright, remove four button-head cap screws (A-928). Lift head cylinder (731198) from handle (722132) and set aside o-ring (S832) and gasket (745124). Empty all hydraulic fluid into a container. Place piston rod wrench (730151) down into top of power cylinder (731237), into slot of piston rod assy. (731233). While holding this wrench, remove flexlock nut (400559) using a 7/16" socket wrench. Still holding piston rod wrench, remove air piston (704121) using packing plug wrench (704150), by turning counterclockwise. When air piston is completely free from piston rod, tap or push on the piston rod wrench to eject air piston from bottom of handle. After removal of air piston, slide piston rod (731233) back up to the end of its travel. Using packing plug wrench (704150) remove packing plug (704118). With packing plug removed, power cylinder (730237) can be removed by pushing on power cylinder tool (704151) when inserted into top of power cylinder.

To reassemble the handle, reverse the above procedure, being certain that all o-rings are properly lubricated before installation. Torque packing plug (704118) to 45 foot lbs. Attach the seal guide (704152) to the piston rod (730233) and tap the piston rod through the packing plug (704118). Attach air piston (704121) and flexlock nut (400559) torque flexlock nut to 40 inch lbs. Attach air piston (704121) to piston rod (731233). With the piston rod in the down position, fill oil passage on top of handle with automatic transmission fluid, ATF220 or equivalent, when looking at top of handle the oil passage is the hole that has a counterbore for S832 o-ring. Replace gasket (745124) and o-ring (S832), just prior to replacing head cylinder (731198). (See Filling & Bleeding instructions).

AIR VALVE

To disassemble, first disconnect tool from its air source. Remove pin (704244) and muffler (704146). Insert valve extractor (S1178) into end of valve plug (704145) and pull it out. Using the same procedure, pull out spool (703142). NOTE: It should never be necessary to remove valve sleeve (703139) unless the ports in the sleeve are plugged from contaminated air. If ports are plugged, use needle nose pliers to grasp end of spring (704141), turning clockwise and pulling to dislodge from groove in casting. NOTE: 704162 valve spring tool will facilitate the proper installation of the spring (704141), valve sleeve (703139) can be pulled out using valve sleeve removal tool 704163.

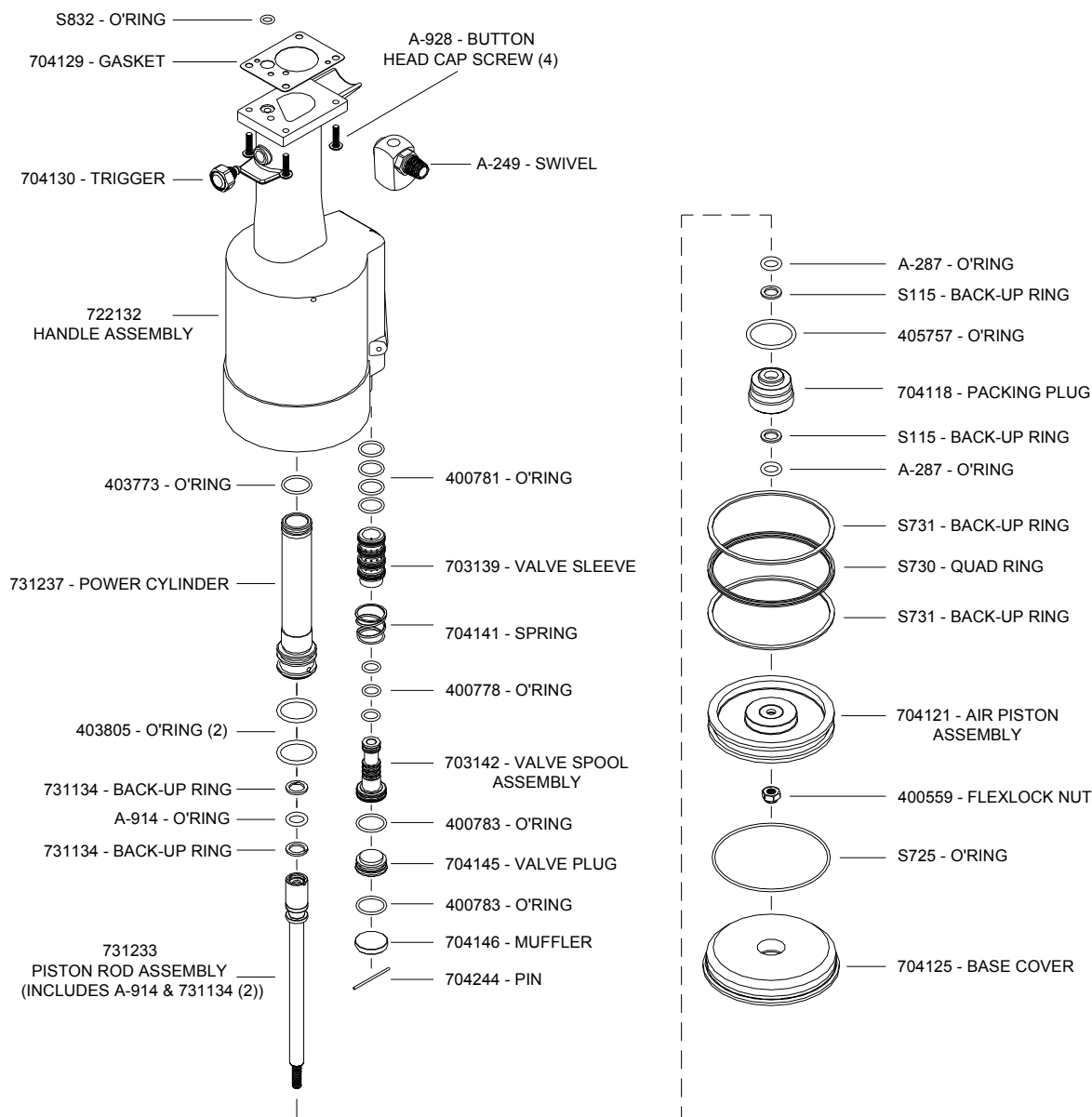

SELECTION CHART FOR GBP731

FASTENER	DIA.	STRAIGHT		*RIGHT ANGLE 1	**OFFSET	
'A' CODE NAS1398 & NAS1399 'A'	3/32	3A-352A-25		3A-751B-54RA		
	1/8	4A-752B-20	4A-752B-45	4A-751B-54RA	4A-752A-43OS	
	5/32	5A-752B-20	5A-752B-45	5A-751B-54RA	5A-752A-43OS	
	3/16	6A-752B-20	6A-752B-45	6A-751B-54RA	6A-752A-43OS	
	1/4	SMLS08-713-20	SMLS08-713-45		SMLS08-752A-43OS	
2 ASP & ASP PF ASP FF & ASP F ASP-LC	13/64	ASP06-752B-20	ASP06-752B-45	ASP06-751B-54RA	ASP06-752A-43OS	
	17/64	ASP08-752B-20	ASP08-752B-45	ASP08-751B-54RA	ASP08-752A-43OS	
LGP LOCKBOLT LGPL2SC-V BACB30VM LGPL18SC-V BACB30XT LGPL4SC-V ABS0548 LGPL2SP-V BACB30VN LGPL4SP-V ASNA2392 LGPL8SC-V BACB30WD LGPL9SC-V BACB30WB LGPL9SP-V BACB30VY	5/32	LGP05-730B-10	LGP05-731-20		LGP05-204B-25OS	LGP05-204B-30OS
		LGP05-731-45			LGP05-204B-34OS	
	3/16	LGP06-730B-10	LGP06-731-20		LGP06-204B-25OS	LGP06-204B-30OS
		LGP06-731-45			LGP06-204B-34OS	
	1/4	LGP08-730B-10	LGP08-731-20		LGP08-204B-25OS	LGP08-204B-30OS
LGP08-731-45		LGP08-204B-34OS				
NAS and GP SHEAR/TENSION LOCKBOLTS BACB30TY BACB30UA BACB30TZ BACB30UB BACB30DY BACB30GX BACB30DX BACB30GP BACB30GO BACB30GY BACB30GW	5/32	NASS05-730B-10	NAST05-730B-10		NASS05-204B-25OS	NAST05-204B-20OS
		NASS05-731-20	NAST05-731-20		NASS05-204B-30OS	NAST05-204B-30OS
	NASS05-731-45	NAST05-731-45	NASS05-204B-34OS		NAST05-204B-34OS	
	3/16	NAS06-730B-10	NAS06-731-20		NA S06-204B-25OS	NAS06-204B-30OS
		NAS06-731-45			NAS06-204B-34OS	
1/4 3	NAS08-730B-10	NAS08-731-20	NAS08-204B-25OS	NAS08-204B-30OS		
NAS08-731-45		NAS08-204B-34OS				
BACR15FR/FP, BACR15GF/GK, NAS1919 & NAS1921 "U" TYPE BLIND RIVET WITH DRIVE WASHER NAS9301-9312	1/8	456MAX-751A-21 2	456MAX-751A-61 2	456MAX-751C-54RA 2	456MAX-752-42OS 2	
	5/32					
	3/16					
	1/4	08MAX-752B-20	08MAX-752B-45	08MAX-713-58RA	08MAX-204C-27OS 08MAX-204C-37OS	
MS90353S & U & MS90354S & U MS21140S & U & MS21141S & U CR7000 SERIES BACB30YY, YU, & YT	5/32	SB05-752B-20	SB05-752B-45	SB05-751B-54RA	SB05-752A-43OS	
		SB05-752B-80				
	3/16	SB06-752B-20	SB06-752B-45		SB06-751B-54RA	SB06-204C-27OS
		SB06-752B-80				
1/4	SB08-713-20	SB08-713-45	SB08-713-58RA	SB08-204C-27OS SB08-204C-37OS		
MS90353 & MS90354 MS21140 & MS21141 "U" TYPE BLIND BOLT WITH DRIVE WASHER	5/32	UBB05-752B-20	UBB05-752B-45	UBB05-751B-54RA	UBB05-752A-43OS	
	3/16	UBB06-752B-20	UBB06-752B-45			UBB06-752A-43OS
	1/4	UBB08-713-20	UBB08-713-45		UBB08-204C-27OS	
EN6122 & UAB130-EU EN6127 & UAB6127-EU EN6128 & UAB100-EU EN6129 & UABP-EU	1/8	UAB04-752B-20	UAB04-752B-45	UAB04-751B-54RA UAB05-751B-54RA UAB06-751B-54RA	UAB04-752A-43OS	
	5/32	UAB568-713-21 4	UAB568-713-61 4			UAB05-752A-43OS UAB06-752A-43OS
	3/16				UAB08-204C-27OS	
		1/4				
SINGLE ACTION BLIND RIVET NAS1919S & U NAS1921S & U	1/8	SMLS04-752B-20	SMLS04-752B-45	SMLS04-751B-54RA SMLS05-751B-54RA SMLS06-751B-54RA SMLS08-713-58RA	SMLS04-752A-43OS	
	5/32	SMLS05-752B-20	SMLS05-752B-45			SMLS05-752A-43OS
	3/16	SMLS06-752B-20	SMLS06-752B-45		SMLS06-752A-43OS	
		1/4	SMLS08-713-20			SMLS08-713-45

THE GAGE BILT GBP731 TOOL IS APPROVED TO INSTALL THE ABOVE FASTENERS.

*ALL RIGHT ANGLE NOSES REQUIRE 731154 STROKE LIMITER.
**ALL OFFSET 204 SERIES NOSES REQUIRE 751204 A DAPTER.
1) RIGHT ANGLE NOSE ASSEMBLIES MAY REQUIRE MORE THAN ONE PULL.
2) INSTALLS 1/8, 5/32 & 3/16 DIAMETERS.
3) NOT FOR TENSION ALLOY
4) INSTALLS 5/32, 3/16 & 1/4 DIAMETERS.

NOTE: THE LAST 2 DIGITS OF THE NOSE ASSEMBLY REPRESENTS THE LENGTH THE NOSE
EXTENDS FROM THE TOOL. IE -20 = 2.0 INCHES

**GAGE BILT ALSO SUPPLIES PIN & COLLAR SWAGE INSPECTION
GAGES TO CERTIFY CORRECT SWAGE INSTALLATION.**



GAGE BILT



DECLARATION OF CONFORMITY

WE DECLARE THAT THE EQUIPMENT SPECIFIED HEREIN
CONFORMS TO THE FOLLOWING STANDARDS AND DIRECTIVES.

EN292 part 1 and part 2
ISO 8662 part 1
ISO 3744
COUNCIL DIRECTIVE: 89/392/EEC, 91/368/EEC
93/44/EEC, 93/68/EEC

EQUIPMENT DESCRIPTION:
GBP700 SERIES FASTENER INSTALLATION TOOLS

MANUFACTURER:
GAGE BILT PRODUCTS CORP.

SIGNATURE: 

NAME: BRUCE T. GODFREY
CHAIRMAN
WARREN, MI U.S.A.
JUNE 2003

WARRANTY

Seller warrants that all goods covered by this catalog will conform to applicable specifications and will replace, or repair, F.O.B. our plant, any goods providing defective from faulty workmanship, or material, for 90 days from date of shipment.

Said warranty to remain in effect if and only if such goods are used in accordance with all instructions as to maintenance, operation, and use set forth in manuals and instruction sheets furnished by seller.

Sellers obligation under this warranty shall be limited to the repair or rework of the goods supplied or replacement thereof, at Seller's option, and in no case is to exceed the invoice value of said goods. Under no circumstances will seller be liable for incidental or consequential damages or for damages incurred by the buyer or subsequent user in repairing or replacing defective goods or if the goods covered by this warranty are reworked or subjected to any type of additional processing.

This warranty is void if Seller is not notified in writing of any rejections or defects within 90 days after the receipt of the material by the customer.

**THIS WARRANTY IS MADE IN LIEU OF ALL OTHER WARRANTIES,
EXPRESS OR IMPLIED, INCLUDING MERCHANTABILITY.**