

GBP751D

INSTALLATION TOOL

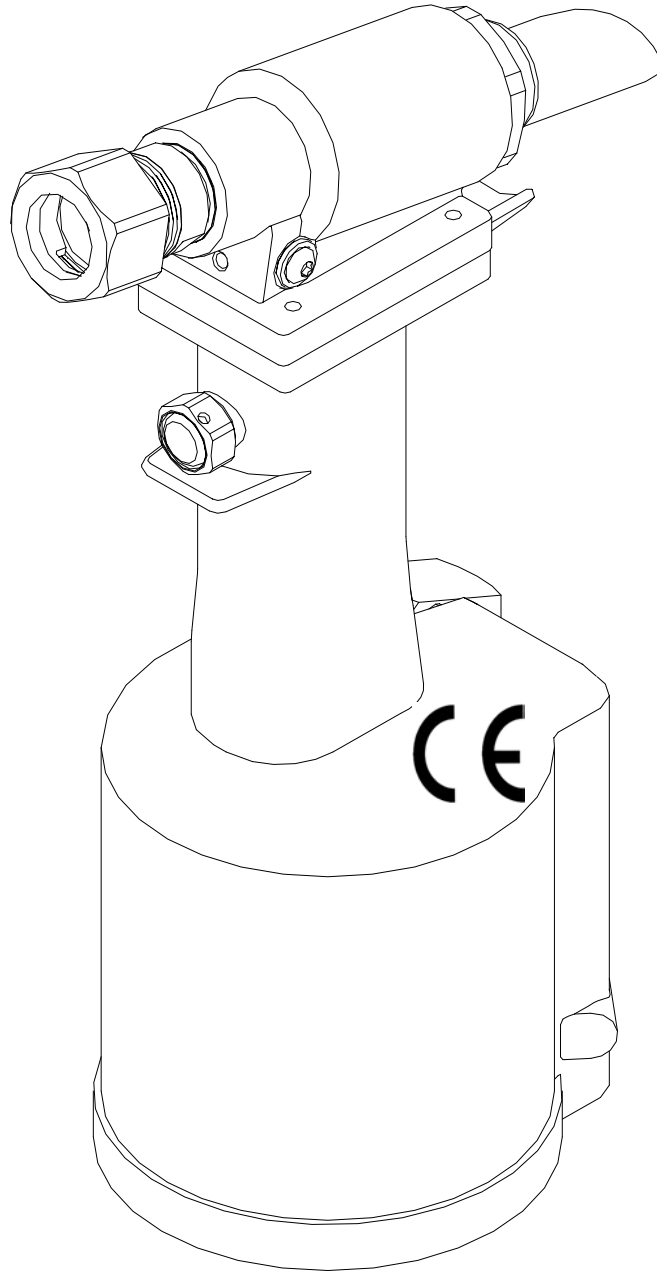

GAGE BILT
MADE IN U.S.A.

GAGE BILT PRODUCTS CORP.

44766 Centre Court (586) 226-1500
Clinton Twp. MI 48038 (586) 226-1505 Fax
e-mail: solutions@gagebilt.com / www.gagebilt.com

TABLE OF CONTENTS

<u>Description</u>	<u>Page</u>
Warnings.....	3
Description, Operation and Maintenance.....	4
Filling, Bleeding and Trouble Shooting.....	5
Overhaul, Disassembly and Parts Lists.....	6-7
Nose Assembly Selection Chart.....	8
EU Conformity and Warranty.....	9

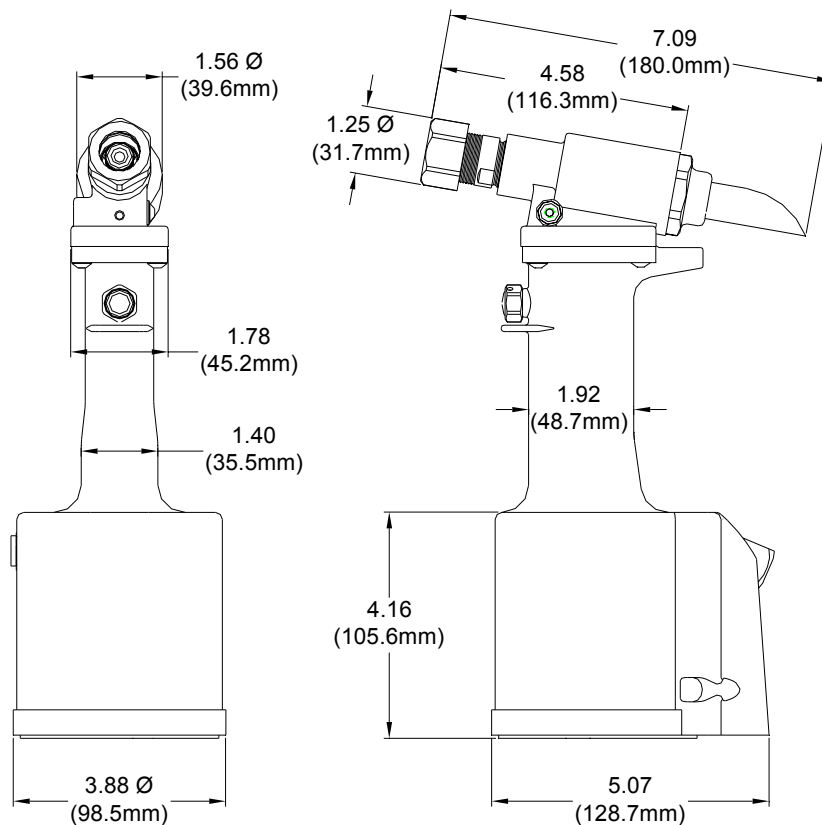

SPECIFICATIONS

- Hand Held Weight** - 4.50 lbs.
- Air pressure req'd** - 90-120 p.s.i.
- Air consumption** - .16 SCF/cycle (4.53 L/cycle)
- Hydraulic fluid** - Automatic Transmission Fluid, Dextron III, or equivalent.

- Setting stroke** - .780"
- Rated pull load** - 2,200 lbs.
- Noise level** - 78.4 dB (A)
- Vibration** - less than 2.5 M/S



NOTE:

PLEASE READ THIS MANUAL BEFORE SERVICING OR USING THIS TOOL. COMPLETE WITH WARNINGS AND CAUTIONS TO PREVENT SEVERE PERSONAL INJURY OR DAMAGE THE TOOL.



CAUTION:

GAGE BILT TOOLS ARE APPROVED TO INSTALL HUCK®, AVDEL®, CHERRY®, POP® AND OTHER FASTENERS WHEN USED BY PERSONS WITH SPECIFIC TRAINING OF BLIND RIVET AND LOCKBOLT INSTALLATION EQUIPMENT.

WARNING

Do not pull fastener unless it is placed in an assembly, pin will eject forcibly when pintail breaks off. Severe personal injury may result.

WARNING

Do not operate without Stat-O-Seal (S572) and cap screw (402482). Pressurized hydraulic fluid may cause severe personal injury.

WARNING

When operating installation equipment always wear approved eye protection. Do not look in front of nose assembly or rear of tool when installing fastener.

WARNING

Always disconnect tool from power before performing any maintenance to any tool or nose assembly. Insure that all connections are proper and there are no visible leaks from tool or hoses before connecting to power.

WARNING

Do not operate if deflector, bottle, catcher bag or vacuum tube is removed or damaged, broken pintails may eject forcibly from rear of tool. Severe personal injury may result.

CAUTION

Insure that nose assembly and tip are properly matched for the fastener being installed.

WARNING

Installation of fasteners may exceed acceptable noise levels. Use approved hearing protection.

WARNING

Be sure there is adequate clearance for tool and operator's hands before proceeding. Keep fingers clear of any moving parts. Keep fingers clear from fasteners and installed materials. Severe personal injury may result.

CAUTION

Keep Nose Assemblies clean and free of chips and debris.

DESCRIPTION

The GBP751D is a pneumatic-hydraulic tool designed specifically for the efficient installation of a wide range of blind rivets. It weighs 4.5 lbs. and can be operated in any position with one hand. It has a .780" rivet setting stroke and a rated pull load of 2200 pounds with 90 psi air pressure at the air inlet.

The GBP751D riveter operates on a wide range of air pressure, with 90 to 100 psi providing the maximum efficiency. At 90 lbs air pressure, the GBP751D does not exceed 85 db (A) and consumes 3 cfm at 20 cycles a minute.

The air inlet is provided with 1/4-18 female pipe threads to accept the users air hose fitting.

NOSE ASSEMBLIES ARE NOT FURNISHED WITH TOOL AND MUST BE ORDERED SEPARATELY. (See page 8 for nose assembly recommendations.)

MAINTENANCE

The performance of any tool depends upon good maintenance practices. Following these minimal requirements for service and care will extend the life of your tool.

- *Only use an air supply set at 90-120 lbs. equipped with a filter-regulator to prevent wear.
- *The tool will eventually lose some hydraulic oil. Keep the hydraulic system full and free of air by using the air bleeder (704153) on a regular basis.
- *Proper care by operator is necessary in maintaining full productivity and reducing downtime. Read all applicable tool manuals and nose assembly data sheets prior to operating tools.
- *Keep nose assemblies, especially jaws, clean and free of chips and debris. Lube jaws and collet surfaces that jaws ride on with light machine oil.
- *For a complete overhaul, tool kit GBP704TK is recommended (see page 6).

CLEANING AND LUBRICATING PROCEDURE

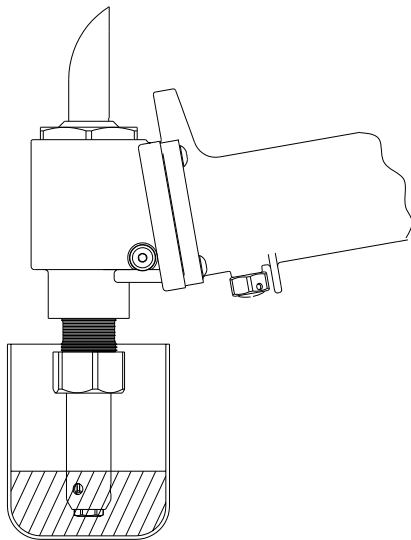

Daily cleaning and lubrication of nose assembly will greatly reduce downtime and increase life of components. Using sewing machine oil, or an equivalent cleaner/lubricant, follow instructions below.

1. Disconnect tool vacuum line (if equipped).
2. Point nose assembly into oil as shown.
3. Cycle tool 8-10 times and wipe dry.

TORQUE SPECIFICATIONS

- Button Head Cap Screws (A-928) = 40 inch lbs.
- Flexlock Nut (400559) = 40 inch lbs.
- Packing Plug (704118) = 45 foot lbs.

FILLING AND BLEEDING TOOL

WARNING

DO NOT CYCLE TOOL WITHOUT AIR BLEEDER, OR THE SCREW AND STAT-O-SEAL, INSTALLED IN TOOL HEAD. SEVERE PERSONAL INJURY MAY RESULT.

CAUTION

BEFORE FILLING HANDLE, AIR PISTON SHOULD BE ALL THE WAY DOWN.

CAUTION WHEN FORCING PISTON ROD ASSEMBLY DOWNWARD WITH HEAD CYLINDER ASSEMBLY REMOVED, HYDRAULIC FLUID WILL EJECT FORCIBLY FROM HANDLE.

To replace a small amount of oil in the tool, attach the air bleeder and connect tool to air line. Cycle a number of times. Disconnect air, remove the air bleeder, and reinstall the cap screw. This will insure the removal of any air from the hydraulic system and its replacement with fluid.

Should it become necessary to completely refill the tool (such as would be required after tool has been dismantled and reassembled), take the following steps after depressing trigger **AND DISCONNECTING THE AIR SUPPLY:**

1. Remove head assembly from handle assembly. Slowly push piston completely forward.
2. Fill handle and the oil passage on top of handle with automatic transmission fluid, ATF220 or equivalent. When looking at the top of the handle, the oil passage is the hole that is counterbored for S832 o'ring.
3. Replace head assembly with care, insuring gasket (704129) and o'ring (S832) are properly installed. Tighten cap screws (A-928 uniformly to prevent leakage around gasket.
4. Remove screw (402482) and stat-o-seal (S572) install bleeder bottle (704153) and connect tool to air line, cycle ten to twenty times to fully circulate fluid through hydraulic system.
5. **DISCONNECT AIR FROM TOOL.** Remove bleeder bottle (704153) install screw (402482) and stat-o-seal (S572). Reconnect air and cycle tool 10 more times. Check tool stroke, if stroke doesn't check .780" min. (See figures below Dim. 'B' - Dim. 'A') repeat steps 4 & 5.

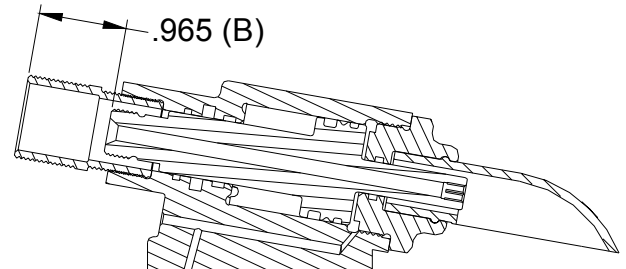
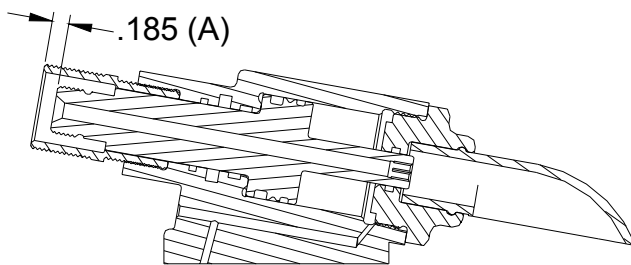

TROUBLE SHOOTING

Providing all maintenance conditions have been met, follow this systematic approach to diagnosis.

1. MORE THAN ONE PULL IS REQUIRED TO BREAK RIVET.
 - a) Tool needs to be bled. (See filling and bleeding instructions.)
 - b) Spring has fatigued, replace.
 - c) Jaws are stripped or packed with chips. Clean or replace.
 - d) Incorrect nose tip.
2. SLOW OR PARTIAL OPERATION WHEN THE TRIGGER IS DEPRESSED
 - a) Head Piston Rings (405865) and (400788) could be worn or damaged. Replace.
 - b) Piston Rod Rings (401102) and (S945) could be worn or damaged. Replace.
 - c) Muffler (704146) or filter inside spool (703142) may be plugged with dirt. Clean thoroughly and back-blow with compressed air.
 - d) Hole in metering screw in valve spool (703142) may be blocked or damaged. Hole diameter should be .028". Clear and size or replace.
3. NO OPERATION WHEN TRIGGER IS DEPRESSED
 - a) Tool seized due to mechanical failure or damaged parts.
4. OIL LEAKAGE
 - a) **DO NOT** OPERATE WITH OIL LEAKING FROM TOOL. HIGH PRESSURE OIL MAY CAUSE SEVERE PERSONAL INJURY.
 - b) Any oil leaking externally should be traced to its source. An o'ring or seal that leaks should be replaced.
5. AIR BYPASS FROM VALVE HOUSING
 - a) If the spring (704141) breaks or dislodges, air will flow freely through the muffler (704146). Replace or reset. Valve spring installation tool (704162) is recommended.
 - b) Check o'rings on valve sleeve (703139), valve spool (703142), and valve plug (704145). If worn or damaged, replace. Valve sleeve removal tool (704163) is recommended.
6. FASTENER STEM JAMMED IN NOSE ASSEMBLY
 - a) Nose assembly components require service. **DISCONNECT AIR FROM TOOL**, remove the nose from the tool and disassemble. Replace worn or broken parts. Clean the surface the jaws ride on.
 - b) Stems lodged side by side in the follower. Disassemble, remove stems, and reassemble.
 - c) Incorrect follower.

OVERHAUL

The disassembly and re-assembly procedure can be accomplished by utilizing the following instructions and drawings. Use extreme care during disassembly and re-assembly not to mar or nick any smooth surface that comes in contact with seals. Before installing seals, always apply a good lubricant, such as Lubriplate, to the surfaces. It is recommended that tool kit (GBP704TK) be used to facilitate overhaul. A complete overhaul can be achieved by the use of Service Kit 703040 which contains a complete set of o-rings, back-up rings, screws, washers and gasket.

WARNING

DEPRESS TRIGGER AND DISCONNECT FROM AIR WITH HEAD PISTON IN THE REAR POSITION BEFORE OVERHAUL. SEVERE PERSONAL INJURY MAY OCCUR IF AIR HOSE IS NOT DISCONNECTED. **USE CAUTION** WHEN FORCING PISTON ROD ASSEMBLY DOWNWARD WITH HEAD CYLINDER ASSEMBLY REMOVED, HYDRAULIC FLUID WILL EJECT FORCIBLY FROM HANDLE.

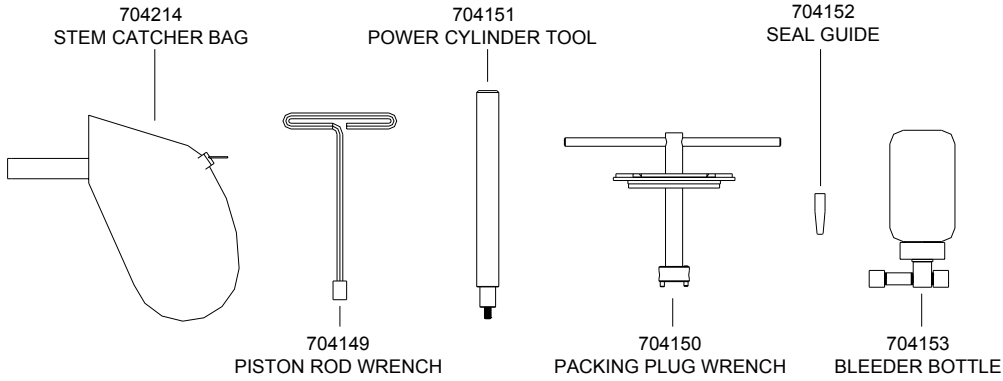

GBP704TK Service Tool Kit Includes:

Part No.	Description
704149	Piston Rod Wrench
704150	Packing Plug Wrench
704151	Power Cylinder Tool
704152	Seal Guide
S1178	Valve Extractor (Not Shown)
704162	Valve Spring Installation Tool (Not Shown)
704163	Valve Sleeve Removal Tool (Not Shown)

HEAD

Remove nose assembly and adapter from tool before attempting disassembly of head assembly.

Remove end cap (703114). Push against threaded end of head piston (751307) to slide it out of head cylinder (703109). Be careful not to damage threads or cause burrs on polished piston rod surface.

The re-assembly sequence is the opposite of disassembly. (See Filling and Bleeding instructions.) Apply Loctite #242 and torque the button head cap screws (A-928) uniformly to 40 inch lbs. to prevent leakage around the gasket.

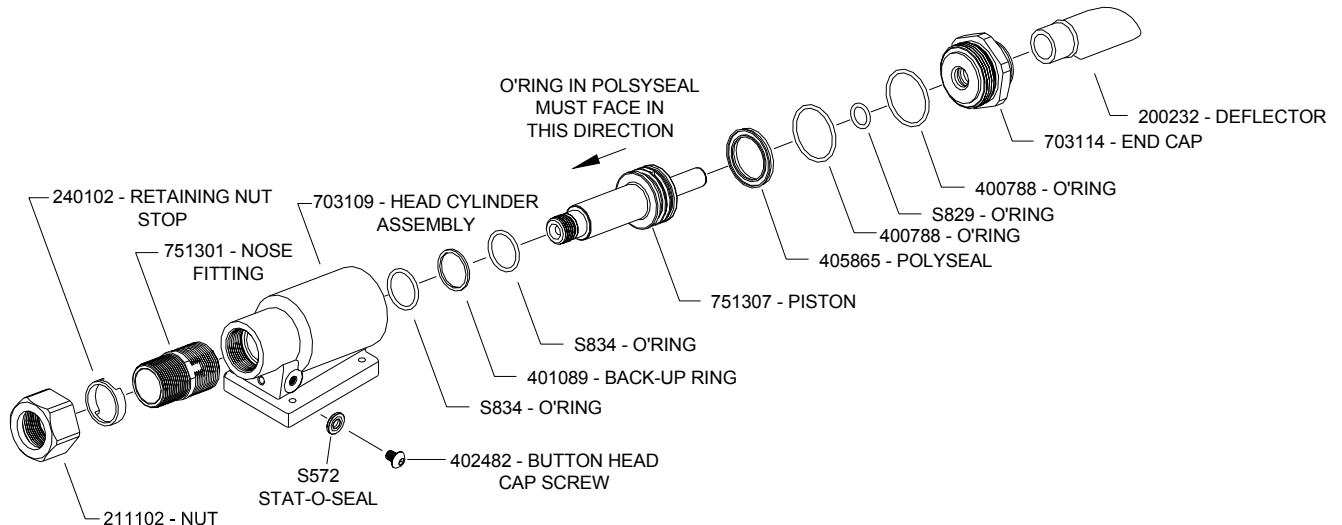

HANDLE

To inspect air cylinder bore, remove base cover (704125). Any further disassembly will require removal of the head cyl. (703109) first. For complete disassembly, start by removing base cover (704125). Next, holding tool upright, remove four button-head cap screws (A-928). Lift head cyl. (703109) from handle (704132) and set aside o-ring (S832) and gasket (704129). Empty all hydraulic fluid into a container. Place piston rod wrench (704149) down into top of power cylinder (751131), into the hex of piston rod assy. (704138). While holding this wrench, remove flexlock nut (400559) using a 7/16" socket wrench. Still holding piston rod wrench, remove air piston (704121) using packing plug wrench (704150), by turning counterclockwise. When air piston is completely free from piston rod, tap or push on the piston rod wrench to eject air piston from bottom of handle. After removal of air piston, slide piston rod (704138) back up to the end of its travel. Using packing plug wrench (704150) remove packing plug (704118). With packing plug removed, power cylinder (751131) can be removed by pushing on power cylinder tool (704151) when inserted into top of power cylinder.

To reassemble the handle, reverse the above procedure, being certain that all o-rings are properly lubricated before installation. Torque packing plug (704118) to 45 foot lbs. Attach the seal guide (704152) to the piston rod (704138) and tap the piston rod through the packing plug (704118). Attach air piston (704121) and flexlock nut (400559) torque flexlock nut to 40 inch lbs. Attach air piston (704121) to piston rod (704138). With the piston rod in the down position, fill oil passage on top of handle with automatic transmission fluid, ATF220 or equivalent, when looking at top of handle the oil passage is the hole that has a counterbore for (S832) o-ring. Replace gasket (704129) and o-ring (S832), just prior to replacing head cyl. (703109). (See Filling & Bleeding instructions.)

AIR VALVE

To disassemble, first disconnect tool from its air source. Remove pin (704244) and muffler (704146). Insert valve extractor (S1178) into end of valve plug (704145) and pull it out. Using the same procedure, pull out spool (703142). NOTE: It should never be necessary to remove valve sleeve (703139) unless the ports in the sleeve are plugged from contaminated air. If ports are plugged, use needle nose pliers to grasp end of spring (704141), turning clockwise and pulling to dislodge from groove in casting. NOTE: 704162 valve spring tool will facilitate the proper installation of the spring (704141), valve sleeve (703139) can be pulled out using valve sleeve removal tool 704163.

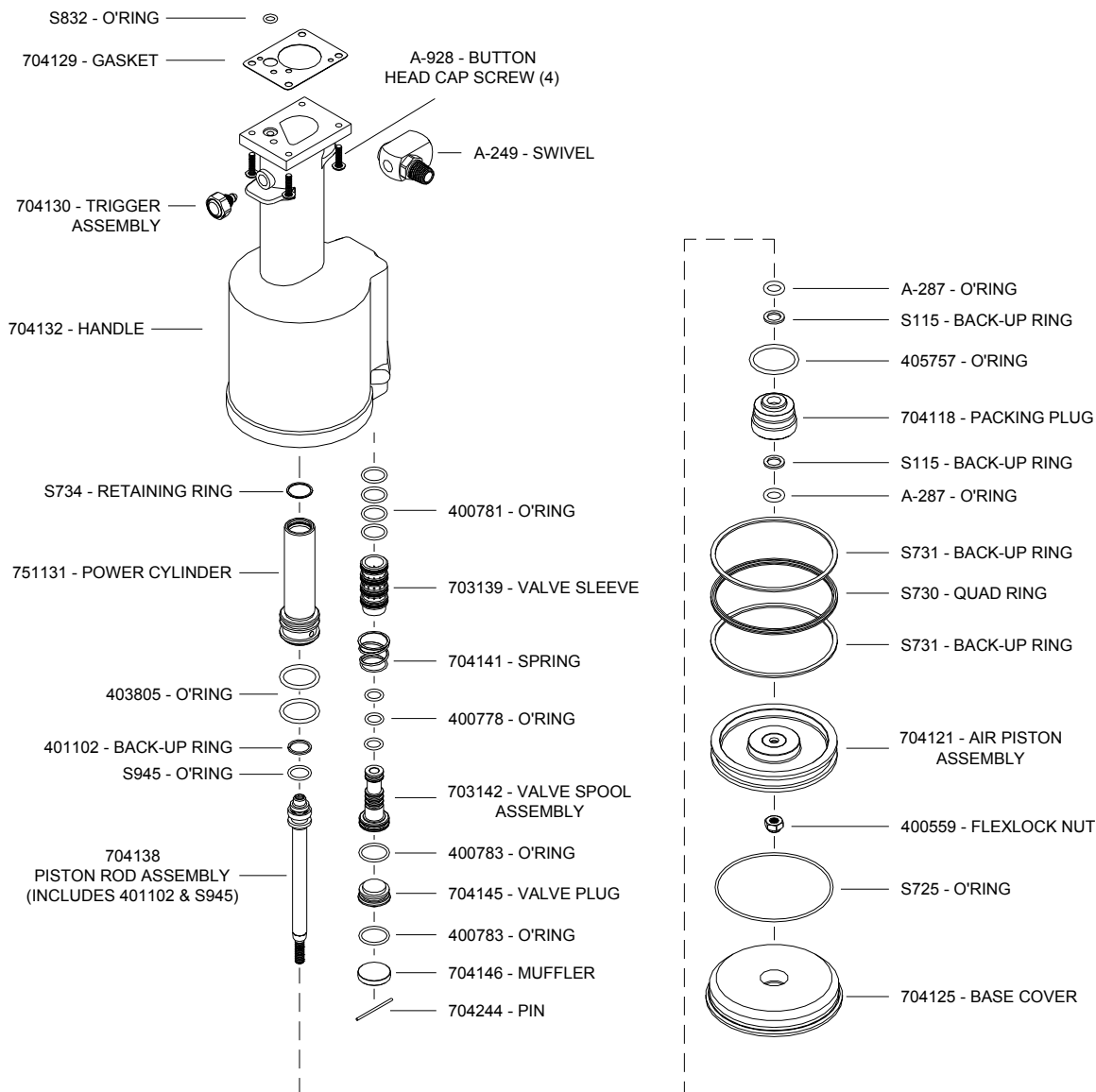

GBP751D SELECTION CHART

FASTENER	DIA.	STRAIGHT		RIGHT ANGLE	OFFSET
MS90353S & U & MS90354S & U MS21140S & U & MS21141S & U CR7000 SERIES BACB30YY, YU, & YT	5/32	SB05-752B-20 SB05-752B-80	SB05-752B-45	SB05-751B-54RA	SB05-752A-43OS
MS90353 & MS90354 MS21140 & MS21141 "U" TYPE BLIND BOLT WITH DRIVE WASHER	5/32	UBB05-752B-20 UBB05-752B-80	UBB05-752B-45	UBB05-751B-54RA	UBB05-752A-43OS
EN6122 & UAB130-EU EN6127 & UAB6127-EU EN6128 & UAB100-EU EN6129 & UABP-EU	5/32	UAB568-713-21	UAB568-713-61	UAB05-751B-54RA	UAB05-752A-43OS
SINGLE ACTION BLIND RIVET NAS1919S & U NAS1921S & U	1/8	SMLS04-752B-20	SMLS04-752B-45	SMLS04-751B-54RA	SMLS04-752A-43OS
	5/32	SMLS05-752B-20	SMLS05-752B-45	SMLS05-751B-54RA	SMLS05-752A-43OS
	3/16	SMLS06-752B-20	SMLS06-752B-45	SMLS06-751B-54RA	SMLS06-752A-43OS
	1/4 ₃	SMLS08-752B-20	SMLS08-752B-45	SMLS08-751B-54RA	SMLS08-752A-43OS ₃
"A" CODE NAS1398A & NAS1399A	3/32	3A-352B-25		3A-751B-54RA	
	1/8	4A-752B-20	4A-752B-45	4A-751B-54RA	4A-752A-43OS
	5/32	5A-752B-20	5A-752B-45	5A-751B-54RA	5A-752A-43OS
	3/16	6A-752B-20	6A-752B-45	6A-751B-54RA	6A-752A-43OS
NUT PLATE RIVETS CCR244/264/274 BACR15DR MS20600	3/32	3NP-352-21	3NP-352-61	3NP-751B-54RA	3NP-751-43OS
	1/8	5N-352-21	5N-352-61	5N-751B-54RA	5N-751-43OS
BACR15FR/FP, BACR15GF/GK, NAS1919 & NAS1921 "U" TYPE BLIND RIVET WITH DRIVE WASHER NAS9301-9312	1/8				
	5/32	456MAX-751A-21 ₂	456MAX-751A-61 ₂	456MAX-751C-54RA ₂	456MAX-752-42OS ₂
	3/16				
ASP 2, ASP PF, ASP 4 FF, ASP 2 F, ASP 2 LC	13/64	ASP06-752B-20	ASP06-752B-45	ASP06-751B-54RA	ASP06-752A-43OS
NAS1719, NAS1720 NAS1721	1/8	MBC04-752B-20	MBC04-752B-45	MBC04-751A-54RA	MBC04-752A-43OS
	5/32	MBC05-752B-20	MBC05-752B-45	MBC05-751A-54RA	MBC05-752A-43OS
	3/16	MBC06-752B-20	MBC06-752B-45	MBC06-751A-54RA	MBC06-752A-43OS
GROUND STUD, M83454 & BACS53B	8/32	GS8-752B-20	GS8-752B-45	GS8-751B-54RA	GS8-752A-43OS
	10/32	GS10-752B-20	GS10-752B-45	GS10-752A-54RA	GS10-752A-43OS
OPEN END, CLOSED END, C'SUNK, PROTRUDING HEAD COMMERCIAL NAIL RIVETS	3/32	3N-352-21	3N-352-61	3N-751B-54RA	3N-751-43OS
	1/8	4N-352-21	4N-352-61	4N-751B-54RA	4N-751-43OS
	5/32	5N-352-21	5N-352-61	5N-751B-54RA	5N-751-43OS
	3/16	6N-352-21	6N-352-61	6N-751B-54RA	6N-751-43OS

THE GAGE BILT GBP751D TOOL IS APPROVED TO INSTALL THE ABOVE FASTENERS

1) RIGHT ANGLE NOSE ASSEMBLYS MAY REQUIRE MORE THAN ONE PULL.

2) INSTALLS 1/8", 5/32" & 3/16" DIAMETERS.

3) ALUMINUM ONLY.

NOTE: THE LAST 2 DIGITS OF THE NOSE ASSEMBLY REPRESENTS THE LENGTH
THE NOSE EXTENDS FROM THE TOOL I.E. -20 = 2.0 INCHES

GAGE BILT



DECLARATION OF CONFORMITY

WE DECLARE THAT THE EQUIPMENT SPECIFIED HEREIN
CONFORMS TO THE FOLLOWING STANDARDS AND DIRECTIVES.

EN292 part 1 and part 2
ISO 8662 part 1
ISO 3744
COUNCIL DIRECTIVE: 89/392/EEC, 91/368/EEC
93/44/EEC, 93/68/EEC

EQUIPMENT DESCRIPTION:
GBP700 SERIES FASTENER INSTALLATION TOOLS

MANUFACTURER:
GAGE BILT PRODUCTS CORP.

SIGNATURE: 

NAME: BRUCE T. GODFREY
CHAIRMAN
WARREN, MI U.S.A.
JUNE 2003

WARRANTY

Seller warrants that all goods covered by this catalog will conform to applicable specifications and will replace, or repair, F.O.B. our plant, any goods providing defective from faulty workmanship, or material, for 90 days from date of shipment.

Said warranty to remain in effect if and only if such goods are used in accordance with all instructions as to maintenance, operation, and use set forth in manuals and instruction sheets furnished by seller.

Sellers obligation under this warranty shall be limited to the repair or rework of the goods supplied or replacement thereof, at Seller's option, and in no case is to exceed the invoice value of said goods. Under no circumstances will seller be liable for incidental or consequential damages or for damages incurred by the buyer or subsequent user in repairing or replacing defective goods or if the goods covered by this warranty are reworked or subjected to any type of additional processing.

This warranty is void if Seller is not notified in writing of any rejections or defects within 90 days after the receipt of the material by the customer.

**THIS WARRANTY IS MADE IN LIEU OF ALL OTHER WARRANTIES,
EXPRESS OR IMPLIED, INCLUDING MERCHANTABILITY.**