

# GBP784B

## INSTALLATION TOOL

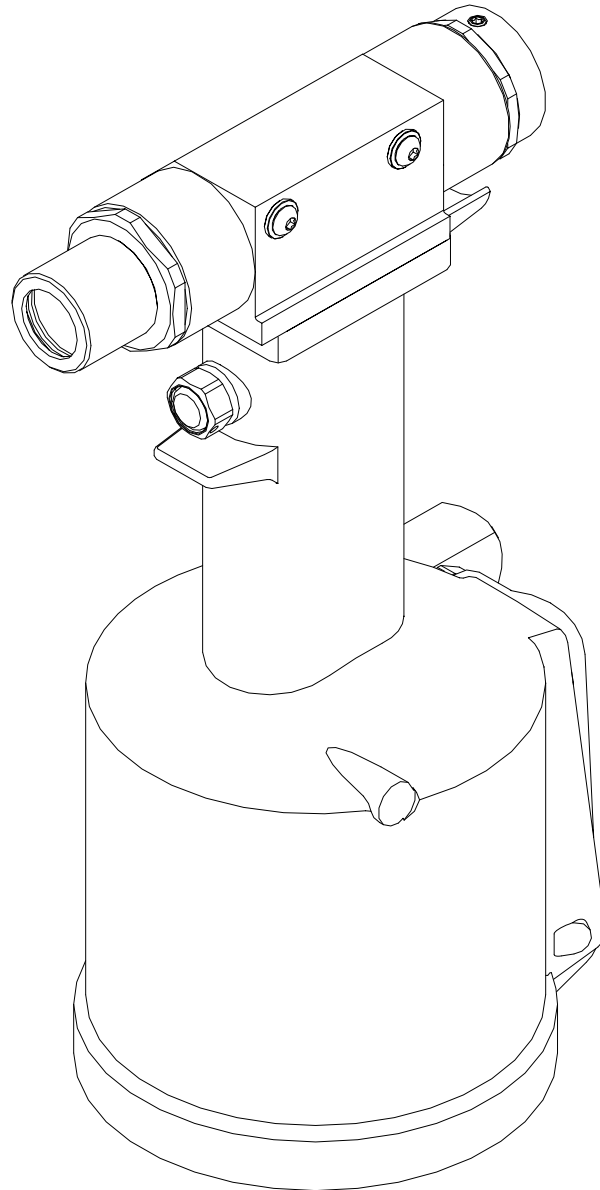

**GAGE BILT**  
MADE IN U.S.A.

**GAGE BILT Inc.**  
44766 Centre Court (586) 226-1500  
Clinton Twp. MI 48038 (586) 226-1505 Fax  
e-mail: [solutions@gagebilt.com](mailto:solutions@gagebilt.com) / [www.gagebilt.com](http://www.gagebilt.com)

## TABLE OF CONTENTS

<u>Description</u>	<u>Page</u>
Warnings.....	3
Description, Operation and Maintenance.....	4
Filling, Bleeding and Troubleshooting.....	5
Parts Breakdown.....	6
Nose Assembly Information.....	7
Shift Settings.....	8
Accessories.....	9

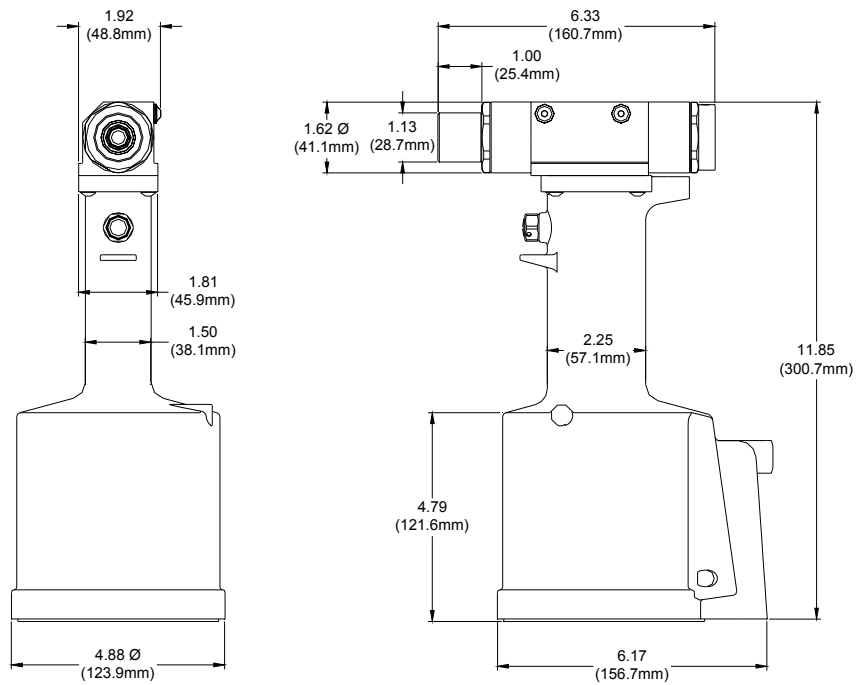

## SPECIFICATIONS

<b>Weight</b>	- 6.25 lbs.
<b>Air pressure req'd</b>	- 90-100 p.s.i.
<b>Air consumption</b>	- 3 c.f.m., based on 20 cycles/min.
<b>Hydraulic fluid</b>	- Automatic Transmission Fluid, Dexron® III, or equivalent.
<b>Setting stroke</b>	- .940"
<b>Rated pull load</b>	- 2,650 lbs.
<b>Noise level</b>	- Does not exceed 85 dB (A)



**NOTE:**

PLEASE READ THIS MANUAL BEFORE SERVICING OR USING THIS TOOL. COMPLETE WITH WARNINGS AND CAUTIONS TO PREVENT SEVERE PERSONAL INJURY OR DAMAGE THE TOOL.



**CAUTION:**

GAGE BILT TOOLS ARE APPROVED TO INSTALL HUCK®, AVDEL®, CHERRY®, POP® AND OTHER FASTENERS WHEN USED BY PERSONS WITH SPECIFIC TRAINING OF BLIND RIVET AND LOCKBOLT INSTALLATION EQUIPMENT.

**WARNING**

Do not pull fastener unless it is placed in an assembly, pin will eject forcibly when pintail breaks off. Severe personal injury may result.

**WARNING**

Do not operate without Stat-O-Seal (S572) and cap screw (402482). Pressurized hydraulic fluid may cause severe personal injury.

**WARNING**

When operating installation equipment always wear approved eye protection. Do not look in front of nose assembly or rear of tool when installing fastener.

**WARNING**

Always disconnect tool from power before performing any maintenance to any tool or nose assembly. Ensure that all connections are proper and there are no visible leaks from tool or hoses before connecting to power.

**WARNING**

Do not operate if deflector, bottle, catcher bag or vacuum tube is removed or damaged, broken pintails may eject forcibly from rear of tool. Severe personal injury may result.

**CAUTION**

Ensure that nose assembly and tip are properly matched for the fastener being installed.

**WARNING**

Installation of fasteners may exceed acceptable noise levels. Use approved hearing protection.

**WARNING**

Be sure there is adequate clearance for tool and operator's hands before proceeding. Keep fingers clear of any moving parts. Keep fingers clear from fasteners and installed materials. Severe personal injury may result.

**CAUTION**

Keep Nose Assemblies clean and free of chips and debris.

**WARNING**

Air pressure not to exceed 100 psi, except where noted.

## DESCRIPTION

The GBP784B is a pneumatic-hydraulic hydro-shift tool designed specifically for the efficient installation of the 2000 series CHERRYLOCK®, NAS1398, NAS1399, NAS1738 and NAS1739 double action blind rivets. The GBP784B weighs only 8 lbs. and can be operated in any position with one hand. It has a .940" rivet setting stroke and a rated pull load of 2650 pounds with 90 psi air pressure at the air inlet.

The GBP784B riveter operates on a wide range of air pressure, with 90 to 100 psi providing the maximum efficiency. At 90 psi air pressure, the GBP784B does not exceed 85 db (A) and consumes 3 cfm at 20 cycles a minute.

The air inlet is provided with 1/4-18 female pipe threads to accept the users air hose fitting.

**TOOL CAPACITY CHART:** The numbers shown in the rivet columns below are the maximum grip length that can be installed with this tool. Dashes indicate those rivet sizes which cannot be installed in any grip length.

GAGE BILT TOOL	STANDARD CHERRYLOCK (NAS1398 & NAS1399)								GAGE BILT TOOL	BULBED CHERRYLOCK (NAS1738 & NAS1739)					
	NOSE ASSEMBLY	RIVET DIAMETER	ALUMINUM		MONEL		STAINLESS			NOSE ASSEMBLY	RIVET DIAMETER	ALUMINUM		MONEL	
			2163 2263	2162 2262	2563	2562	2643 2653 2663	2642 2652 2662				2239 2249	2238 2248	2539	2538
			UNIV. HEAD	CTSK. HEAD	UNIV. HEAD	CTSK. HEAD	UNIV. HEAD	CTSK. HEAD				UNIV. HEAD	CTSK. HEAD	UNIV. HEAD	CTSK. HEAD
GBP784	XX-681-25	-4	ALL	ALL	ALL	ALL	ALL	ALL	ALL	-4	ALL	ALL	ALL	ALL	
		-5	8	8	8	9	8	9	-5	ALL	ALL	ALL	ALL		
		-6	8	8	8	9	8	9	-6	ALL	ALL	ALL*	ALL*		
		-8	8	8	8	9	-	-	-8	ALL	ALL	ALL*	ALL*		

**\*95 psi. required**

Gage Bilt's GBP784B is approved to install the above fasteners.

## MAINTENANCE

The performance of any tool depends upon good maintenance practices. Following these minimal requirements for service and care will extend the life of your tool.

- \*Only use an air supply set at 90-100 psi. equipped with a filter-regulator to prevent wear.
- \*The tool will eventually lose some hydraulic oil. Keep the hydraulic system full and free of air by using the air bleeder (704153) on a regular basis.
- \*Proper care by operator is necessary in maintaining full productivity and reducing downtime. Read all applicable tool manuals and nose assembly data sheets prior to operating tools.
- \*Keep nose assemblies, especially jaws, clean and free of chips and debris.
- \*Service Kit 784004 contains a complete set of o'rings, back-up rings, screws, washers and gasket.
- \*For a complete overhaul, tool kit GBP743ATK is recommended (see page 8).

## TORQUE SPECIFICATIONS

- Button Head Cap Screws (402479) = 40 inch lbs.
- Packing Plug (744118) = 45 foot lbs.
- Flexlock Nut (400559) = 40 inch lbs.
- Rear Cap (784132) = 140 foot lbs.
- Front Cap (784103) = 140 foot lbs.

## FILLING AND BLEEDING TOOL

### **WARNING**

DO NOT CYCLE TOOL WITHOUT AIR BLEEDER, OR THE SCREW AND STAT-O-SEAL, INSTALLED IN TOOL HEAD. SEVERE PERSONAL INJURY MAY RESULT.

### **CAUTION**

BEFORE FILLING HANDLE, AIR PISTON SHOULD BE ALL THE WAY DOWN.

To replace a small amount of oil in the tool, remove rear screw (402482) and stat-o-seal (S572) attach the air bleeder (704153) and connect tool to air line. Cycle a number of times. Disconnect air, remove the air bleeder, and reinstall the cap screw. This will ensure the removal of any air from the hydraulic system and its replacement with fluid.

Should it become necessary to completely refill the tool (such as would be required after tool has been dismantled and reassembled), take the following steps after depressing trigger **AND DISCONNECTING THE AIR SUPPLY:**

1. Remove head assembly from handle assembly. Slowly push piston completely forward. Remove adjuster ring (784138). Turn adjuster knob assembly (784139) completely in clockwise, then back out two turns counterclockwise. This will set gage point #1 very close. It will need to be readjusted slightly after bleeding is complete using setting gage 784159.
2. Fill handle and the oil passage on top of handle with automatic transmission fluid, Dexron III or equivalent. When looking at the top of the handle, the oil passage is the hole that is counterbored for S832 o'ring.
3. Replace head assembly with care, insuring gasket (704129) and o'ring (S832) are properly installed. Tighten cap screws (402479) uniformly to prevent leakage around gasket.
4. Using a pressure oil can filled with automatic transmission fluid, Dexron III or equivalent. Force the fluid into the front hole until it flows freely from the rear hole until the air bubbles stop appearing at rear hole.

### **NOTE**

If fluid does not flow freely, remove base cover and push air piston down, about 1". This will open oil valve on piston rod assembly. Replace base cover. Repeat step 4.

5. Remove bottle from front hole and place bottle at rear hole and reverse step 4.
6. Install front screw (402482) and stat-o-seal (S572)
7. Remove rear screw (402482) and stat-o-seal (S572) install bleeder bottle (704153) and connect tool to air line, cycle ten to twenty times to fully circulate fluid through hydraulic system.
8. **DISCONNECT AIR FROM TOOL.** Remove bleeder bottle (704153) install screw (402482) and stat-o-seal (S572). Reconnect air and cycle tool 10 more times. Check tool stroke, if stroke doesn't check .900" min. repeat steps 7 & 8.

## TROUBLE SHOOTING

Providing all maintenance conditions have been met, follow this systematic approach to diagnosis.

1. **MORE THAN ONE PULL IS REQUIRED TO BREAK RIVET.**
  - a) Tool needs to be bled. (See filling and bleeding instructions.)
  - b) Spring has fatigued, replace.
  - c) Jaws are stripped or packed with chips. Clean or replace.
  - d) Incorrect nose tip.
2. **SLOW OR PARTIAL OPERATION WHEN THE TRIGGER IS DEPRESSED**
  - e) Head Piston Rings (400845) and (S657) could be worn or damaged. Replace.
  - f) Piston Rod Rings (S908) and (A-201) could be worn or damaged. Replace.
  - g) Muffler (744143) or filter inside spool (743142) may be plugged with dirt. Clean thoroughly and back-blow with compressed air.
  - h) Hole in metering screw in valve spool (743142) may be blocked or damaged. Hole diameter should be .028". Clear and size or replace.
3. **NO OPERATION WHEN TRIGGER IS DEPRESSED**
  - a) Tool seized due to mechanical failure or damaged parts.
4. **OIL LEAKAGE**
  - a) **DO NOT OPERATE WITH OIL LEAKING FROM TOOL. HIGH PRESSURE OIL MAY CAUSE SEVERE PERSONAL INJURY.**
  - b) Any oil leaking externally should be traced to its source. An o'ring or seal that leaks should be replaced.
5. **AIR BYPASS FROM VALVE HOUSING**
  - a) If the spring (744144) breaks or dislodges, air will flow freely through the muffler (744143). Replace or reset. Valve spring installation tool (744151) is recommended.
  - b) Check o'rings on valve sleeve (743144), valve spool (743142), and valve plug (744142). If worn or damaged, replace. Valve sleeve removal tool (744152) is recommended.
6. **FASTENER STEM JAMMED IN NOSE ASSEMBLY**
  - a) Nose assembly components require service. **DISCONNECT AIR FROM TOOL**, remove the nose from the tool and disassemble. Replace worn or broken parts. Clean the surface the jaws ride on.
  - b) Stems lodged side by side in the follower. Disassemble, remove stems, and reassemble.

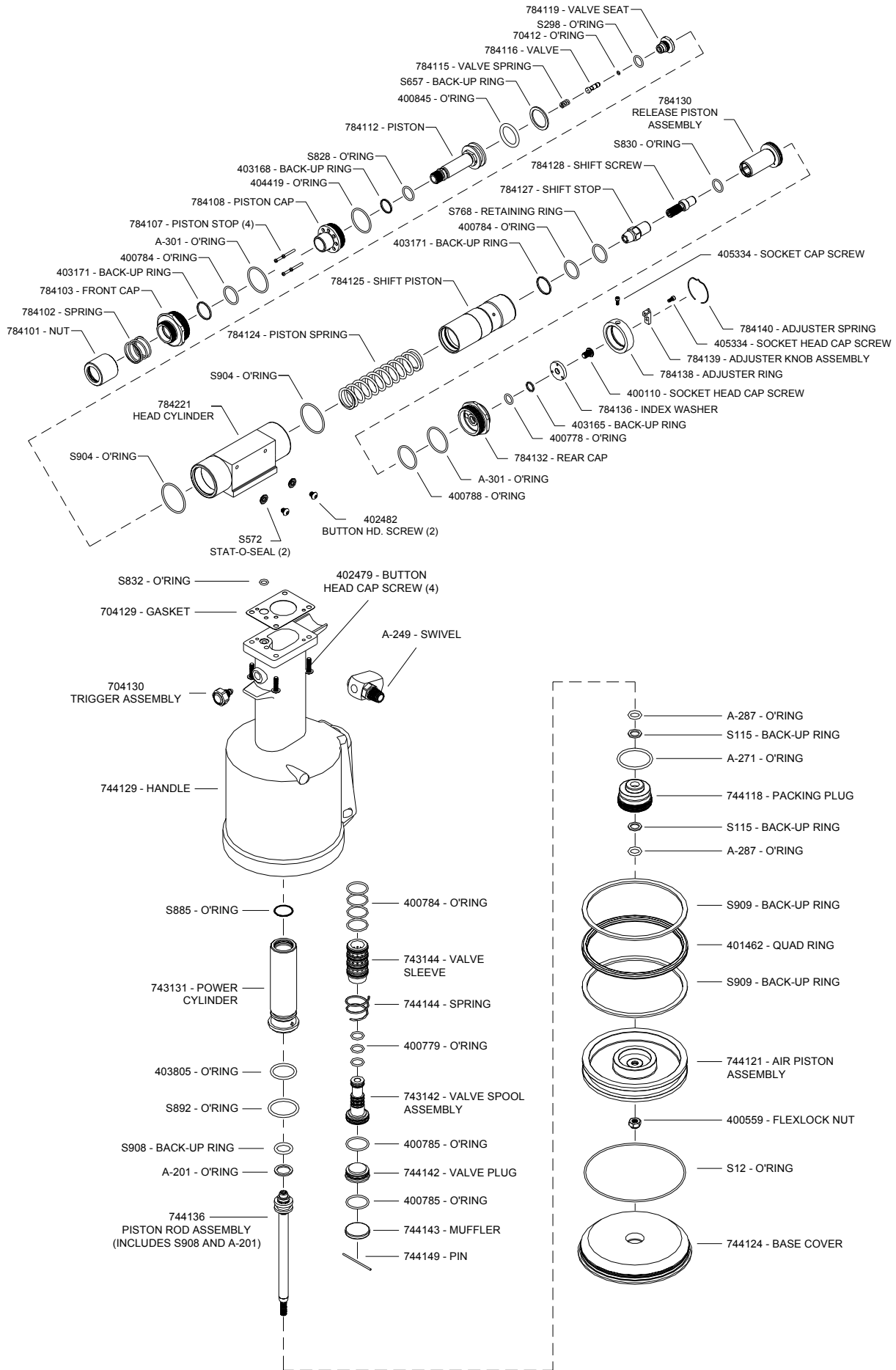

## NOSE ASSEMBLIES:

Nose assemblies are not furnished with the tool and must be purchased separately. In ordering heads be sure to specify the shank diameter and head style (universal or countersunk) of the rivets to be installed.

The following pulling heads will fit directly on the GBP784B Riveter. (NOTE: Cherry 681 series pulling heads fit directly on the GBP784B)

### 681 PULLING HEADS FOR 2000 SERIES CHERRYLOCK RIVETS CONFORMING TO NAS 1400 & NAS 1740

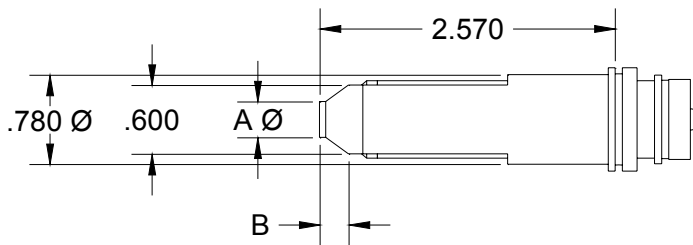

RIVET DIAMETER	NOSE ASSEMBLY	DIMENSION	
		A	B
3/32"	3U-681-25	.188	.348
3/32"	3C-681-25	.163	.332
1/8"	4U-681-25	.250	.341
1/8"	4C-681-25	.208	.377
5/32"	5U-681-25	.313	.377
5/32"	5C-681-25	.269	.352
3/16"	6U-681-25	.375	.418
3/16"	6C-681-25	.335	.386
1/4"	8U-681-25	.500	.452
1/4"	8C-681-25	.458	.398

### INSTALLING 681 PULLING HEAD ON RIVETER

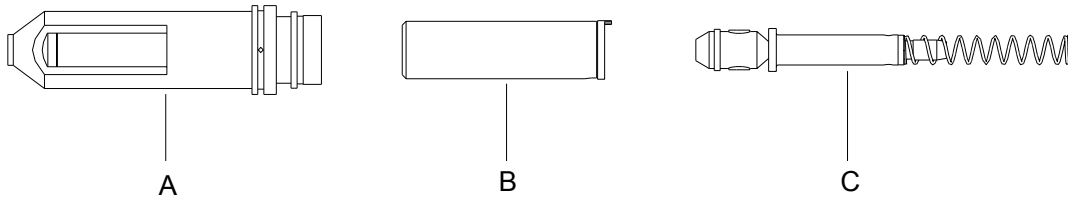

1. Remove knurled cap from front of riveter head.
2. Place jaw assembly (C) inside collet (B).
3. Insert spring end of jaw assembly into hole of head piston. Apply enough pressure to engage collet threads. Turn until collet bottoms on shoulder of piston and collet lock snaps into slot in piston. Hand tight is sufficient.

NOTE: To remove collet, push collet lock back into collet (using a blunt pointed tool) turning the collet clockwise.

4. Place sleeve assembly (A) over collet and head piston. Slip knurled cap over the sleeve assembly and hand tighten onto end of riveter head.

## SETTING THE SHIFT POINT:

The shift point must be adjusted to ensure the flushness of the rivet stem after installation. To Adjust:

1. Connect the tool to a clean dry air source of 90 psi to 100 psi. Remove nut.
2. Hand tighten small end of 784159 gage onto piston.
3. Depress trigger and hold. Gage point #1 should line up with face of front cap as shown. Release Trigger.
4. To increase gage protrusion turn adjuster knob clockwise or counter-clockwise to decrease gage protrusion. Tool must be rechecked after making adjustments.

**NOTE:** Adjustment can only be made by one-half turn in either direction.

**CAUTION:** Trigger must be released before turning adjuster knob.

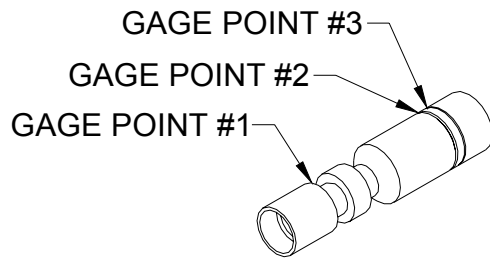

784159 - SETTING GAGE

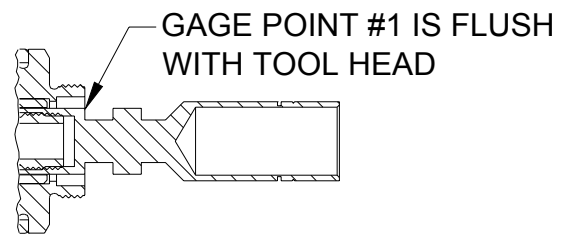

## SHIFT PISTON CHECK:

The shift piston should be checked to ensure that the shift stroke is complete.

1. Connect the tool to a clean dry air source of 90 psi to 100 psi. Remove nut.
2. Install large unthreaded end of 784159 gage over threads on piston until it seats on pistons shoulder, gage point #2 must line up with front of tool as shown in figure A.
3. Depress and hold trigger. The piston should shift gage in forward position exposing gage point #3 in front of tool head as shown in figure B.
4. If tool fails to meet the above check it should be overhauled.

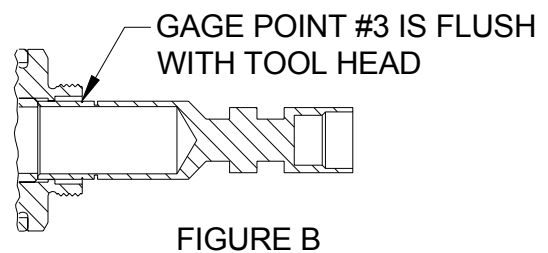
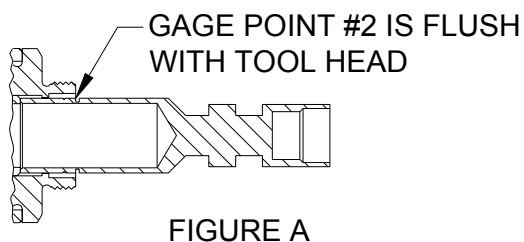

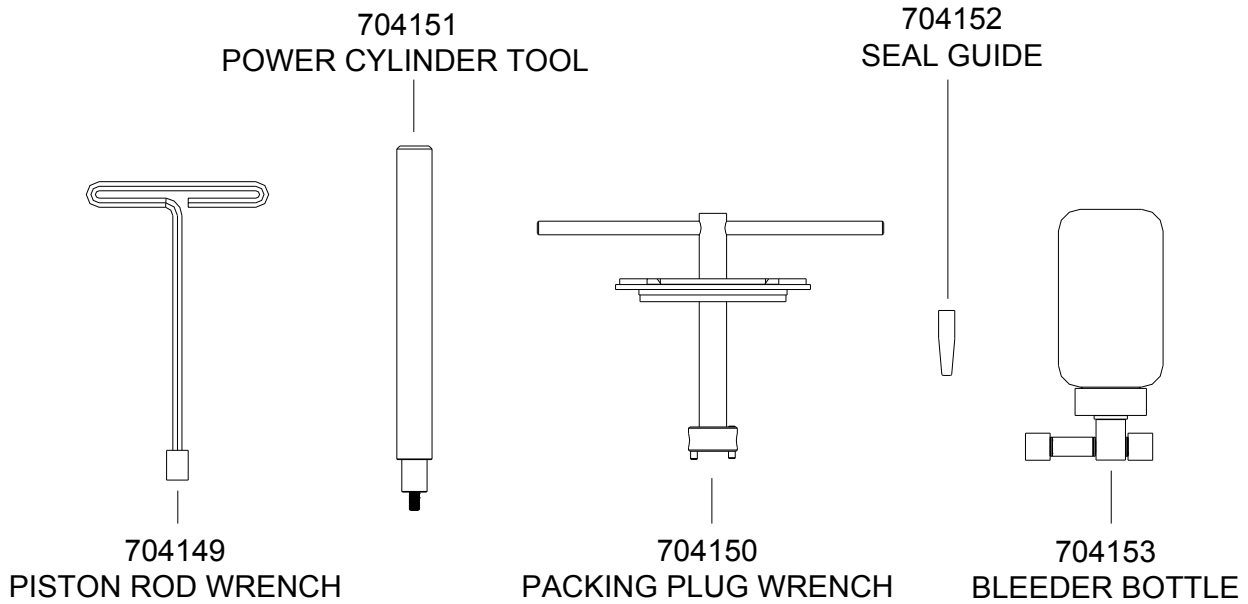

### GBP743ATK Service Tool Kit

Part No.	Description
704149	Piston Rod Wrench
704150	Packing Plug Wrench
704151	Power Cylinder Tool
704152	Seal Guide
S1178	Valve Extractor (Not Shown)
744151	Valve Spring Installation Tool (Not Shown)
744152	Valve Sleeve Removal Tool (Not Shown)

#### WARRANTY

Seller warrants that all goods covered by this catalog will conform to applicable specifications and will replace, or repair, F.O.B. our plant, any goods providing defective from faulty workmanship, or material, for 90 days from date of shipment.

Said warranty to remain in effect if and only if such goods are used in accordance with all instructions as to maintenance, operation, and use set forth in manuals and instruction sheets furnished by seller.

Sellers obligation under this warranty shall be limited to the repair or rework of the goods supplied or replacement thereof, at Seller's option, and in no case is to exceed the invoice value of said goods. Under no circumstances will seller be liable for incidental or consequential damages or for damages incurred by the buyer or subsequent user in repairing or replacing defective goods or if the goods covered by this warranty are reworked or subjected to any type of additional processing.

This warranty is void if Seller is not notified in writing of any rejections or defects within 90 days after the receipt of the material by the customer.

**THIS WARRANTY IS MADE IN LIEU OF ALL OTHER WARRANTIES, EXPRESS OR IMPLIED, INCLUDING MERCHANTABILITY.**