

GBP585

HYDRAULIC INSTALLATION TOOL

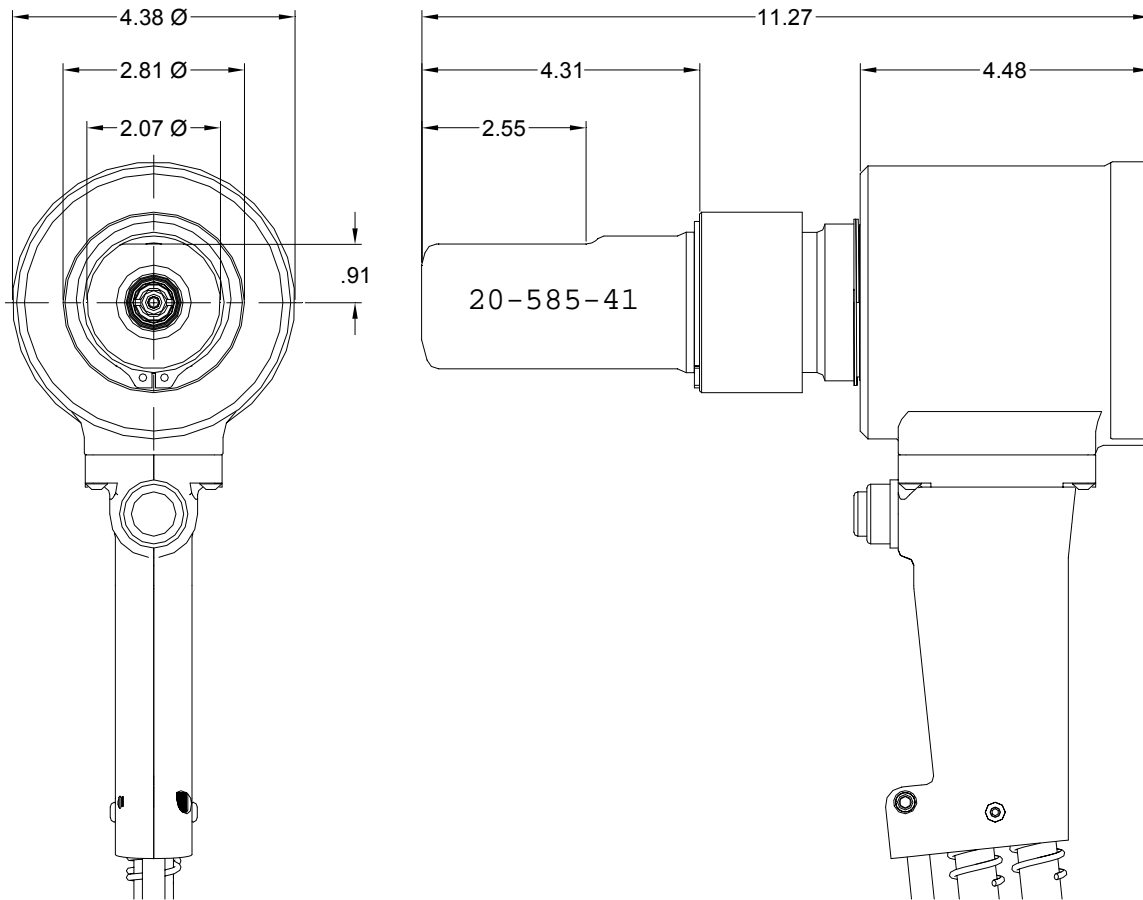

DESCRIPTION

The GBP585 is a hydraulic installation tool capable of installing 5/8" and 3/4" HP8 or standard lockbolts. It weighs just under 20 lbs. and is our most powerful hand tool. It has a 1.600" rivet setting stroke and a rated pull load of 40,000 lbs.

The GBP585 installation tool operates on hydraulic pressure developed by the GBP940 Powerunit set at 5400-5700 psi PULL pressure and 2200-2400 psi RETURN pressure. The tool comes equipped with 24" hoses and electric cord kit complete with quick disconnects.

NOSE ASSEMBLIES ARE NOT FURNISHED WITH THE RIVETER AND MUST BE ORDERED SEPARATELY.

GAGE BILT
MADE IN U.S.A.

GAGE BILT PRODUCTS CORP.

14500 Barber Drive

Warren, Mi 48088

e-mail:solutions@gagebilt.com / www.gagebilt.com

(586) 771-7664

(586) 771-2665 Fax

GBP585 SELECTION CHART

FASTENER	DIA.	NOSE ASSEMBLY
LOCKBOLT HIGH TENSILE PULL TYPE C50L	5/8 3/4	20-585-41 24-585-46
BLIND OVERSIZE MANDREL	5/8 3/4	BOM20-585-41 BOM24-585-46
HP8	5/8 3/4	HP20-585-41 HP24-585-46
MHP 10.9	16MM * 20MM ¹	HP20-585-41 HP20MM-585-46

*FOR NON-PRODUCTION APPLICATIONS ONLY

1) POWER UNIT REQUIRES ADJUSTMENT TO 7,200 PSI FOR PULL AND 4,000 PSI FOR RETURN

NOSE ASSEMBLY KEY

20-585-41

- A ~The first numerical digit represent the diameter of the fastener in 32nds of an inch. (20/32)
- B ~The second set of digits represent ONE of the tool models which MAY be used with this head. (Model 585)
- C ~The last set of numerical digits signify the “Gun Line”, or reach of the pulling head to the nearest tenth of an inch. (41 is 4.1 inch “Gun Line”)