

# GB51

## PNEUMATIC INSTALLATION TOOL

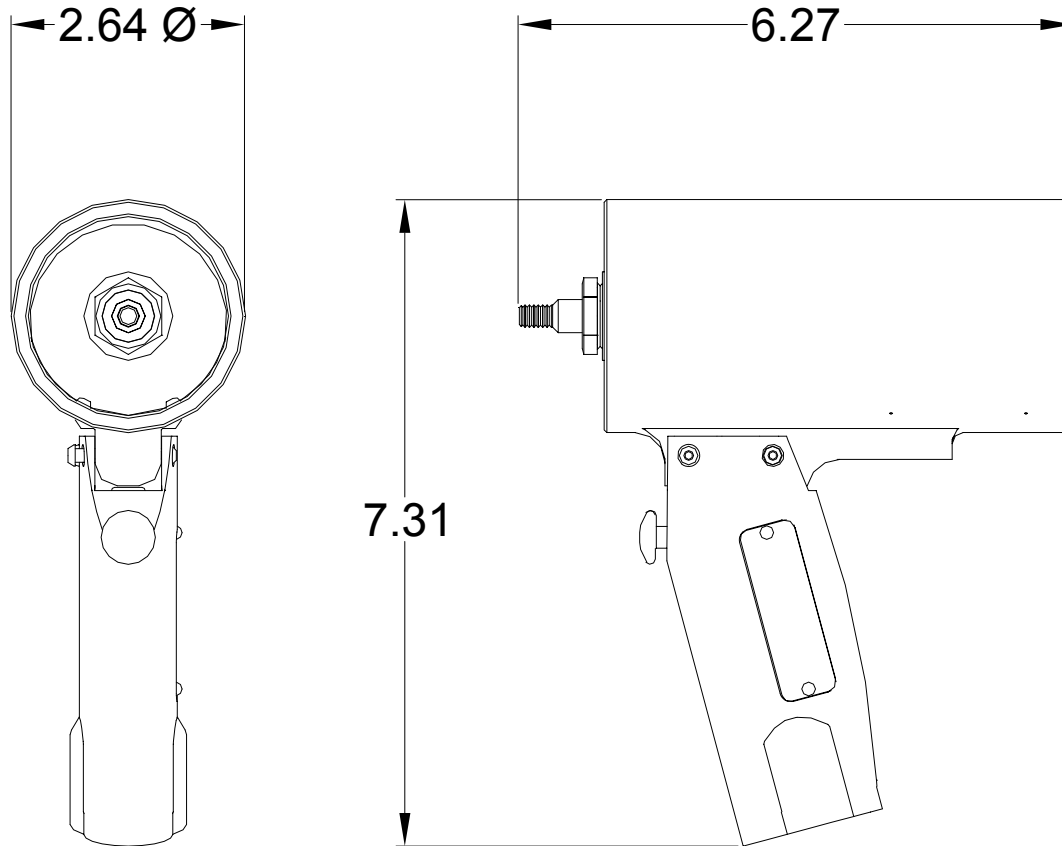

### DESCRIPTION

The GB51 pneumatic riveter is designed specifically for the most efficient installation of a wide range of blind rivets. It will install aluminum rivets through 3/16" diameter, and through 1/8" diameter rivets in any material. It weighs only 2 1/2 lbs. and can be operated in any position with one hand.

The GB51 Riveter is 7" high, has a .740 stroke and generates a minimum of 1000 lbs. of pull at 90 psi. It operates from 80 to 110 psi of air pressure at the tool.

**NOSE ASSEMBLIES ARE NOT FURNISHED WITH THIS TOOL AND MUST BE PURCHASED SEPARATELY.**

**GAGE BILT**  
MADE IN U.S.A.

**GAGE BILT PRODUCTS CORP.**

14500 Barber Drive

(586) 771-7664

Warren, Mi 48088

(586) 771-2665 Fax

e-mail:solutions@gagebilt.com / www.gagebilt.com

# GB51 SELECTION CHART



FASTENER	DIA.	STRAIGHT	RIGHT ANGLE <sup>1,6</sup>	OFFSET
NUT PLATE RIVETS MS20600 SERIES CCR244/264/274 MS/9SP/PT BACR15CC/CF/DA/DR	3/32 1/8 5/32 <sub>3</sub> 3/16 <sub>3</sub>	3C-715B-43 4C-715B-43 5C-715B-43 6C-715B-43	3C-715-54RA 4C-715-54RA 5C-715-54RA 6C-715-54RA	3C-715-40OS 4C-715-40OS 5C-715-40OS 6C-715-40OS
"A" CODE NAS1398A, NAS1399A NAS1740A, NAS1739A	3/32 1/8 5/32 <sub>3</sub> 3/16 <sub>5</sub>	3A-715B-43 4A-715B-43 5A-715B-43 6A-715B-43	3A-715-54RA 4A-715-54RA 5A-715-54RA 6A-715-54RA	3A-715-40OS 4A-715-40OS 5A-715-40OS 6A-715-40OS
NAS1919S & 1921S	1/8 5/32 <sub>3</sub> 3/16 <sub>3</sub>	SMLS04-715B-43 SMLS05-715B-43 SMLS06-715B-43	SMLS04-715-54RA SMLS05-715-54RA SMLS06-715-54RA	SMLS04-715A-40OS SMLS05-715A-40OS SMLS06-715A-40OS
UNIMATIC® SINGLE ACTION NAS1919U & NAS1621U NAS9301-NAS9312 BACR14FP/FR & BACR15GF/GK	1/8 5/32 <sub>3</sub> 3/16 <sub>3</sub>	UBR04-715B-43 UBR05-715B-43 UBR06-715B-43	UBR04-715-54RA UBR05-715-54RA UBR06-715-54RA	UBR04-715-40OS UBR05-715-40OS UBR06-715-40OS
NAS1919U & 1921U	1/8 5/32 <sub>3</sub> 3/16 <sub>3</sub>	456MAX-715-43 <sub>2</sub>	456MAX-715-54RA <sub>2</sub>	456MAX-715-40OS <sub>2</sub>
N, Q & E POP®, CLOSED END AVEX® & COMMERCIAL RIVETS	3/32 1/8 5/32 <sub>3</sub> 3/16 <sub>3</sub>	3N-715E-43 4N-715E-43 5N-715E-43 6N-715E-43	3N-715-54RA 4N-715-54RA 5N-715-54RA 6N-715-54RA	3N-715-40OS 4N-715-40OS 5N-715-40OS 6N-715-40OS

**THE GAGE BILT GB51 TOOL IS APPROVED TO INSTALL THE ABOVE FASTENERS.**

1) RIGHT ANGLE NOSE ASSEMBLYS MAY REQUIRE MORE THAN ONE PULL.
2) INSTALLS 1/8, 5/32 & 3/16 DIAMETERS.
3) ALUMINUM ONLY.
4) ALUMINUM & STEEL ONLY.
5) SELF-PLUGGING ALUMINUM ONLY
6) RIGHT ANGLE NOSE ASSEMBLYS REQUIRE 510152 STROKE LIMITER.
*ALL COUNTERSUNK 'C' NOSE ASSEMBLYS MAY BE USED TO INTSALL BOTH UNIVERSAL & COUNTERSUNK HEAD RIVETS

NOTE: THE LAST 2 DIGITS OF THE NOSE ASSEMBLY REPRESENTS THE LENGTH THE NOSE  
EXTENDS FROM THE TOOL I.E. -20 = 2.0 INCHES