

GBP205 GBP205A

HYDRAULIC INSTALLATION TOOL

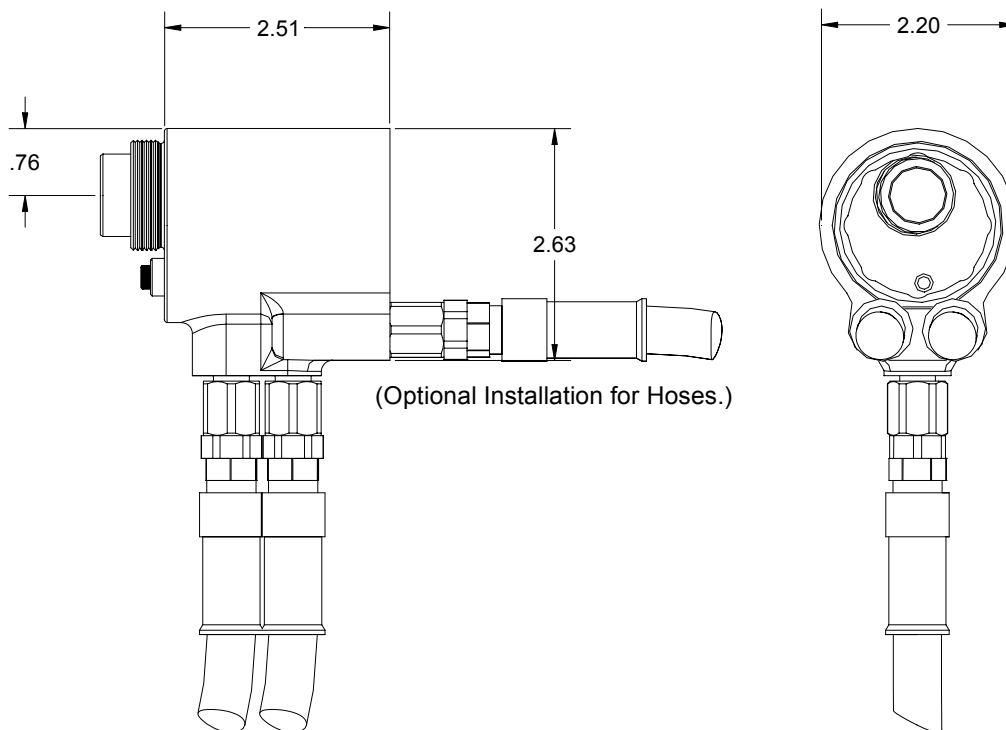

DESCRIPTION

The GBP205 and the GBP205A are hydraulic installation tools designed specifically for the efficient installation of a wide range of blind rivets and lockbolt fasteners thru 3/8" diameter. It weighs just over 4 lbs. and can be operated in any position with one hand. It has a .750 rivet setting stroke and a rated pull load of 10,000 lbs.

The GBP205 installation tool operates on hydraulic pressure developed by the GBP940 Powerunit set at 5600 to psi maximum PULL pressure and 2400 psi maximum RETURN pressure. The tool comes equipped with 12 feet of hydraulic hoses and couplings, electric switch and cord. The GBP205A installation tool operates on hydraulic pressure developed by the GBP910 Powerunit set at 5600 psi maximum PULL pressure and 2400 psi maximum RETURN pressure. The tool comes equipped with 12 feet of hydraulic hoses, swivels and couplings, air trigger and tube.

ALL GBP HYDRAULIC INSTALLATION TOOLS ARE COMPATIBLE WITH HUCK POWERUNIT'S. NOSE ASSEMBLIES ARE NOT FURNISHED WITH THESE TOOLS AND MUST BE ORDERED SEPARATELY.

GAGE BILT
MADE IN U.S.A.

GAGE BILT PRODUCTS CORP.
14500 Barber Drive (586) 771-7664
Warren, Mi 48088 (586) 771-2665 Fax
e-mail: solutions@gagebilt.com / www.gagebilt.com

GBP205 SELECTION CHART



| FASTENER | DIA. | NOSE ASSEMBLY |
|--|--------|---------------|
| PULL-IN HI-LITE | 9/16" | HL18-205B-35 |
| | 5/8" | HL20-205B-35 |
| | 3/4" | HL24-205B-35 |
| | 7/8" | HL28-205B-35 |
| | 1" | HL32-205B-35 |
| | 1-1/4" | HL36-205B-35 |
| LOCKBOLT, NAS SHEAR PULL TYPE, NAS TENSION PULL TYPE, NASS = SHEAR & GP NAST = TENSION | 1/4" | NAS08-205A-31 |
| | 5/16" | NAS10-205A-31 |
| | 3/8" | NAS12-205A-31 |
| Light weight Groove Proportion LOCKBOLT | 1/4" | LGP08-205A-31 |
| | 5/16" | LGP10-205A-31 |
| | 3/8" | LGP12-205A-31 |
| SINGLE ACTION BLIND BOLT MS90353S & U, MS90354S & U MS12140S & U, MS21141S & U | 1/4" | SB08-205A-35 |
| | 5/16" | SB10-205A-35 |
| | 3/8" | SB12-205A-35 |

THE GBP205 IS APPROVED TO INSTALL THE ABOVE FASTENERS.

*TO REDUCE STROKE TO .625" UNLOADING VALVE (208109) AND STROKE LIMITER (208112) ARE AVAILABLE.

NOTE: THE LAST 2 DIGITS OF THE NOSE ASSEMBLY REPRESENTS THE LENGTH THE NOSE ASSEMBLY EXTENDS FROM THE TOOL. (I.e. -25 = 2.5 inches)

GAGE BILT ALSO SUPPLIES PIN & COLLAR SWAGE INSPECTION GAGES TO CERTIFY CORRECT SWAGE INSTALLATION.

