

# NOSE ASSEMBLY DATA SHEET

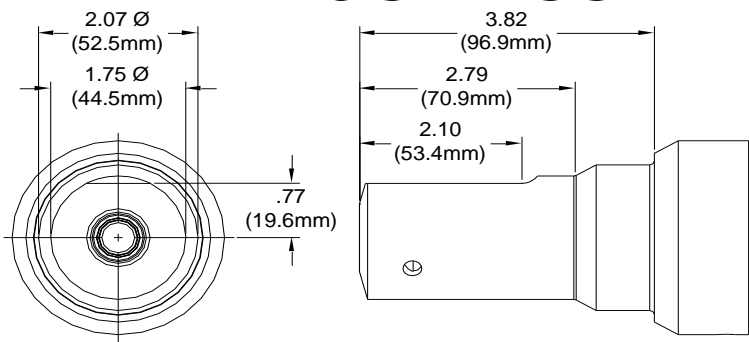

1. Drop sleeve into tool adapter.
2. Hand screw collet onto piston until it stops.
3. Unscrew collet to align ball lock assembly with closest groove on piston. Screw in set screw
4. Slide anvil over collet.
5. Slide nut over anvil and tighten.

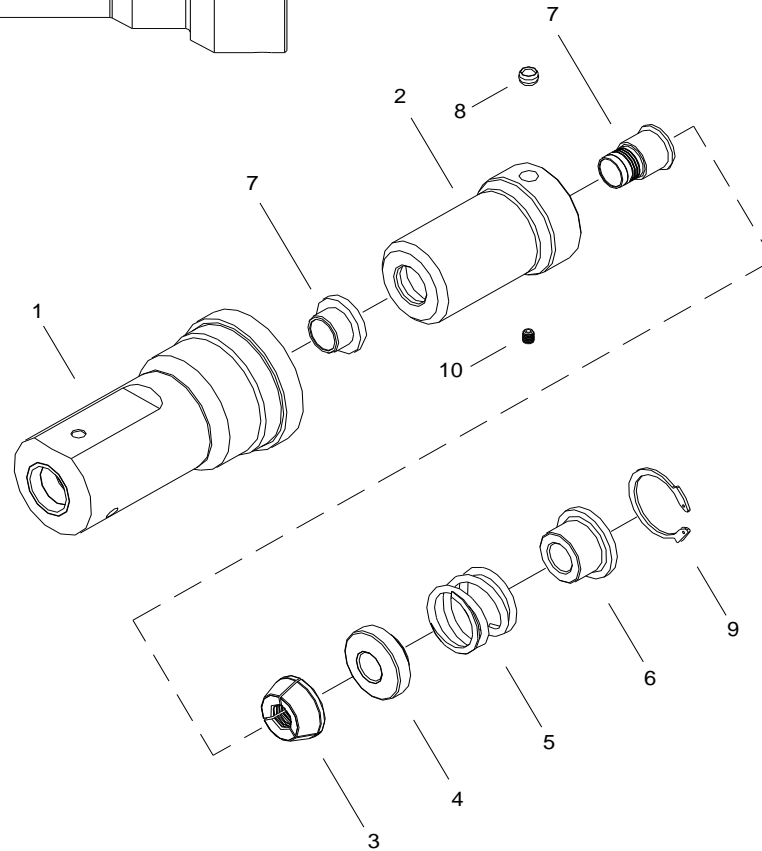

Rev. 2/06

## GAGE BILT

## GAGE BILT Inc.

44766 Centre Court (586) 226-1500  
 Clinton Twp., MI 48038 (586) 226-1505 Fax  
 e-mail: solutions@gagebilt.com / www.gagebilt.com

Type:		Fastener:	Recommended Tool:
Self-Releasing 1/2" Ø		C50L®	GBP7500A(A)
Ref. No.	Qty.	Description	16-7500B-41
1	1	Anvil	11620
2	1	Collet Assembly (Inc. 7 & 8)	21611
3	1	Jaw Set	31601
4	1	Follower	41608
5	1	Spring	52007
6	1	Sleeve	61611
7	1	Release & Ejector Kit	81600
8	1	Ball Lock Assembly	54502
9	1	Retaining Ring	402263
10	1	Set Screw	A-280