

353204-1 ADAPTER DATA SHEET

To attach adapter and nose to tool:

1. Remove nut from drawbar on nose assembly, nut not to be used with adapter assembly.
2. Insert large end of nut (3) into threaded end of collet. Thread collet adapter (2) onto head piston.
3. Ensure collet is installed in anvil on nose assembly.
4. Slide anvil adapter (1) over collet adapter (2) and lock into place on tool. Slide drawbar into nose assembly thru adapter assembly.
5. Using tee-wrench (4) thru rear of installation tool and 1/4" allen wrench on front of nose assembly drawbar tighten nut to drawbar.

CAUTION

Pintail may eject forcibly.
Used for closed access applications only to prevent severe personal injury!

To remove adapter and nose from tool
reverse assembly instructions

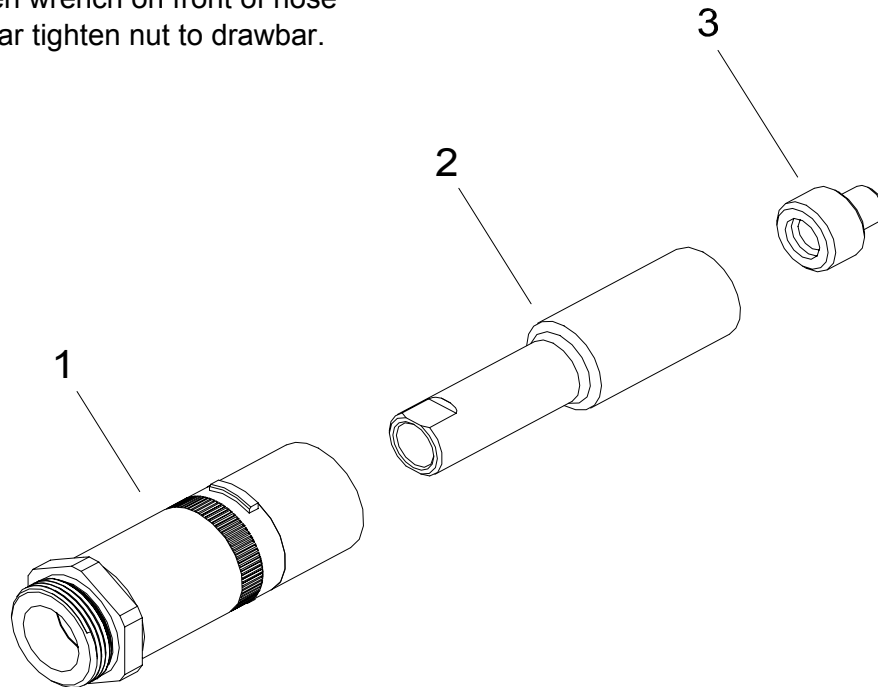

6/03

GAGE BILT

GAGE BILT Inc.

44766 Centre Court (586) 226-1500
Clinton Twp., MI 48038 (586) 226-1505 Fax
e-mail:solutions@gagebilt.com / www.gagebilt.com

Type:

Rotatable
Offset Nose Assembly
Adapter

Adapts GB204A Series Nose Assemblies to:
G87 Installation Tool

Ref. No.	Qty.	Description	353204-1
1	1	Anvil Adapter	353220
2	1	Collet Adapter	353221
3	1	Nut	353222
4	1	Tee-Wrench	A-133