

NOSE ASSEMBLY DATA SHEET

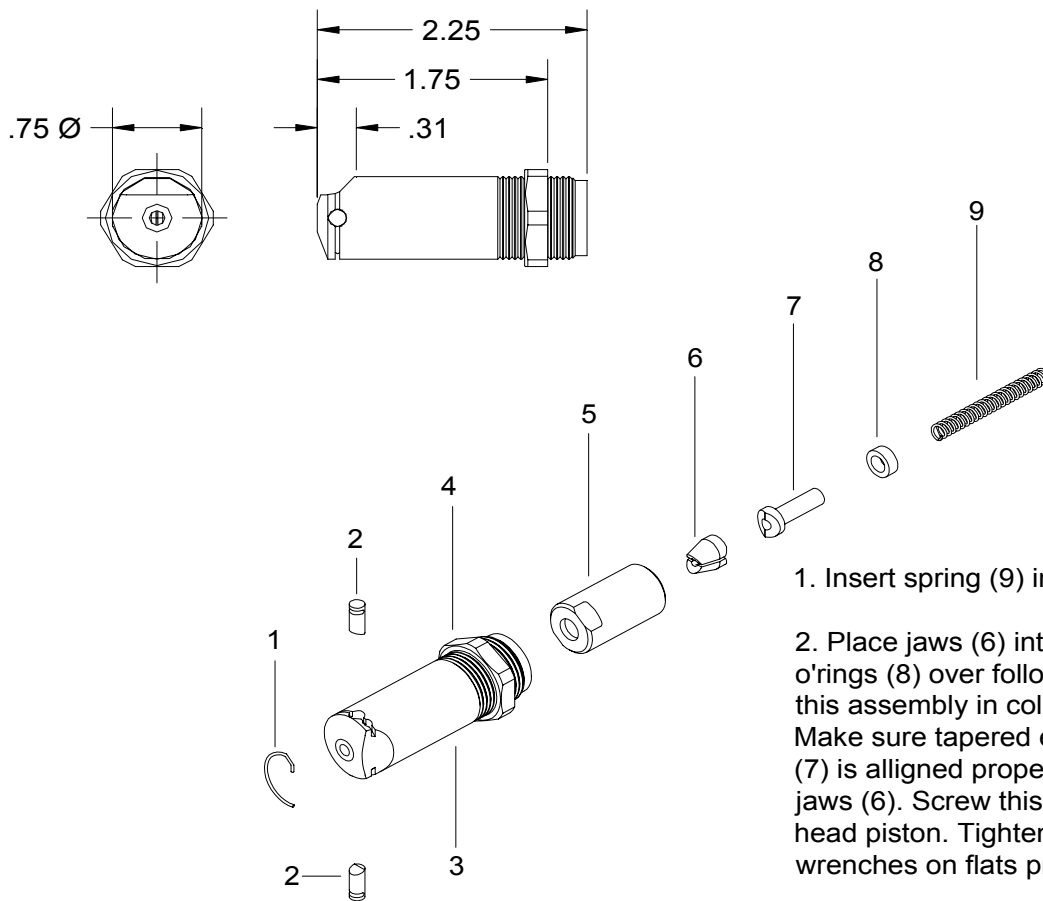

1. Insert spring (9) into head piston on tool.

2. Place jaws (6) into collet (5). Place o-rings (8) over follower (7) and place this assembly in collet against jaws. Make sure tapered end of jaw follower (7) is aligned properly in bevel in back of jaws (6). Screw this assembly onto end of head piston. Tighten securely, using wrenches on flats provided.

3. Thread outer sleeve (3), which contains jam nut (4), snugly into end of head cylinder. Tighten jam nut (4) securely.

KEEP NOSE ASSEMBLIES CLEAN



3/06 Rev.1/11

GAGE BILT
MADE IN U.S.A.

GAGE BILT Inc.

44766 Centre Court (586) 226-1500
Clinton Twp. MI 48038 (586) 226-1505 Fax
e-mail:solutions@gagebilt.com / www.gagebilt.com

Type:		Fastener:		Recommended Tool: GB704
Non Self-Releasing 5/32" \varnothing		NUT PLATE BACR15CC/CF/DA/DR		
Ref. No.	Qty.	Description	3NP-704-17	
1	1	Retaining Ring	70101	
2	2	Stem Stop	70102	
3	1	Sleeve	12213	
4	1	Jam Nut	70104	
5	1	Collet	70105	
6	1	Jaw Set (2 pcs.)	30513	
7	1	Follower	40506	
8	1	Bumper	70108	
9	1	Spring	70109	