

NOSE ASSEMBLY DATA SHEET

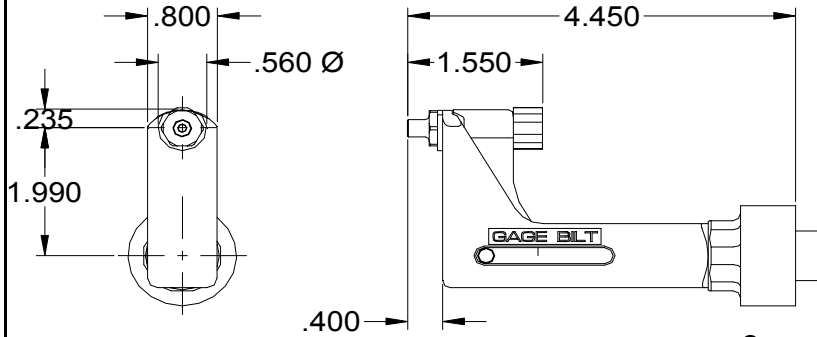

Attachment:

Screw nose assembly onto tool until it stops then back off until nose is in desired position. (Warning: do not back off nose assembly more than one complete turn). Lock jam nut (70336) against adapter (70331).

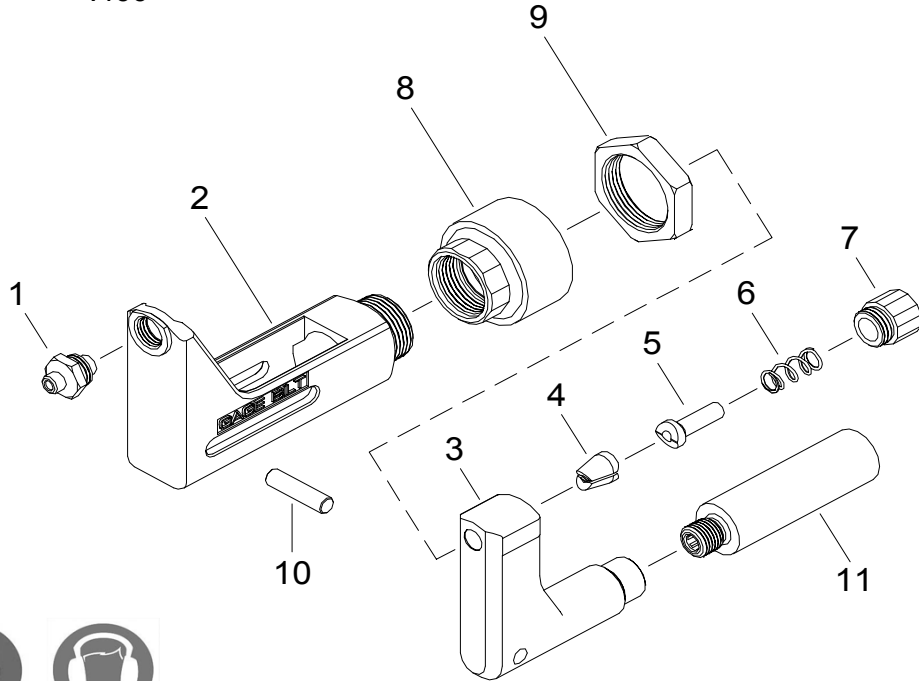

10/07



GAGE BILT
MADE IN U.S.A.

GAGE BILT Inc.

44766 Centre Court (586) 226-1500
Clinton Twp. MI 48038 (586) 226-1505 Fax
e-mail:solutions@gagebilt.com / www.gagebilt.com

Type:		Fasteners:		Recommended Tool:
Non Self-Releasing 3/32" Ø		NUT PLATE RIVETS MS20600-MS20605		GB751
				Alternate Tools: GB752, GB722 & GB2480
Ref. No.	Qty.	Description	3NP 751-430S	
1	1	Nose Tip	10231	
2	1	Anvil Holder	13368	
3	1	Collet	20914	
4	1	Jaw Set	30617	
5	1	Follower	40506	
6	1	Spring	50418	
7	1	Cap	60429	
8	1	Anvil Adapter	70331	
9	1	Jam Nut	70336	
10	1	Pin	70468	
11	1	Collet Adapter	70332	