

NOSE ASSEMBLY DATA SHEET

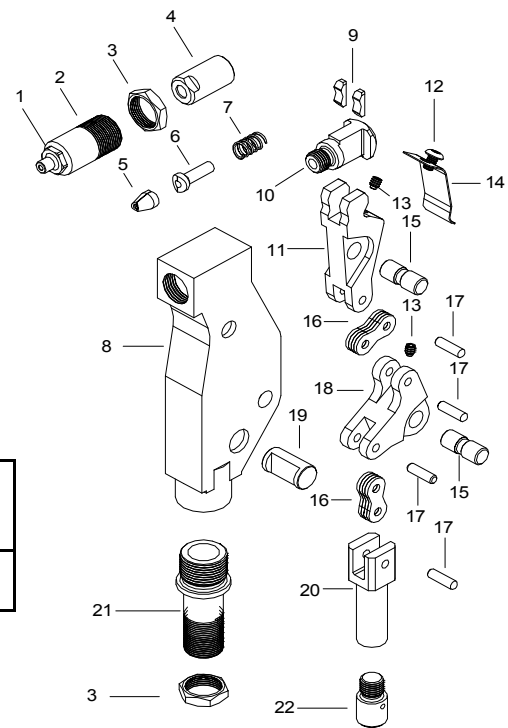
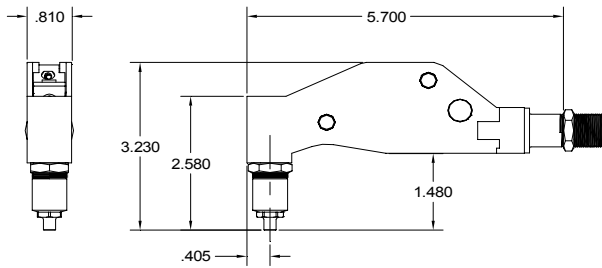

CAUTION!

Pintails may eject forcibly. This nose is for closed access applications. If used in open access applications, 704214 catcher bag is recommended TO PREVENT SEVERE PERSONAL INJURY.

*RECOMMENDED FOR MAINTENANCE APPLICATIONS ONLY.

N, Q & E, POP®, CLOSED END, AVEX® & COMMERCIAL RIVETS	3/32 1/8	3N-715-54RA 4N-715-54RA	10247 10202
NUT PLATE RIVETS	3/32 1/8	4N-715-54RA 4NP-715-54RA	10202 10203

3/05 REV 3/11

GAGE BILT GAGE BILT Inc.

44766 Centre Court (586) 226-1500
Clinton Twp., MI 48038 (586) 226-1505 Fax
e-mail:solutions@gagebilt.com / www.gagebilt.com

Type:	Fasteners:	Recommended Tool: GBP715C
Single Action Self Releasing 1/8", 5/32" & 3/16" Ø	See Chart	
		Alternate Tool: GB51

ATTACHMENT:

Connect tool to air supply. Push adapter-frame (21) and collet extension (22) against head piston and nose fitting on tool and simultaneously thread both adapter-frame (21) and collet extension (22) onto tool. After nose is tight tighten jam nut (3) against face of tool.

DISASSEMBLY:

Loosen jam nut (3) and remove sleeve (2). Unscrew collet (4) which contains jaws (5), follower (6), and spring (7) from collet bolt (10).

Remove screw (12) and guard (14). Remove 2 set screws (13) and push out 2 pivot pins (15) to permit removal of linkage. Shoe bearings (9) and collet bolt (10) will disengage from lever (11).

Remove 4 link pins (17) to disassemble lever (11), links (16), bell crank (18) and drawbolt (20).

Remove guide pin (19) from frame (8). Adapter fitting (21) is secured to frame with Loctite® and need not be removed unless damaged.

REASSEMBLY:

Reverse the procedure. Linkage, consisting of lever (11), links (16), bell crank (18) and drawbolt (20) should be assembled as a subassembly before inserting lever (11) into shoe bearings (9) and collet bolt (10). This complete subassembly may then be inserted into frame (8) and retained by guide pin (19) and pivot pins (15).

Ref. No.	Qty.	Description	3X-715-54RA
1	1	Nose Tip	See Chart
2	1	Sleeve	10125
3	1	Jam Nut	70411
4	1	Collet	20327
5	1	Jaw Set	30617
6	1	Follower	40506
7	1	Spring	50420
8	1	Frame	75310
9	2	Shoe Bearing	75311
10	1	Collet Bolt	70443-1
11	1	Lever	75313
12	1	But. Hd Screw	402471
13	2	Set Screw	75315
14	1	Guard	75316
15	2	Pivot Pin	75317
16	8	Link	75318
17	4	Link Pin	75319
18	1	Bell Crank	75320
19	1	Guide Pin	75321
20	1	Drawbolt	75322
21	1	Adapter-Frame	70458
22	1	Collet Extension	70457