

NOSE ASSEMBLY DATA SHEET

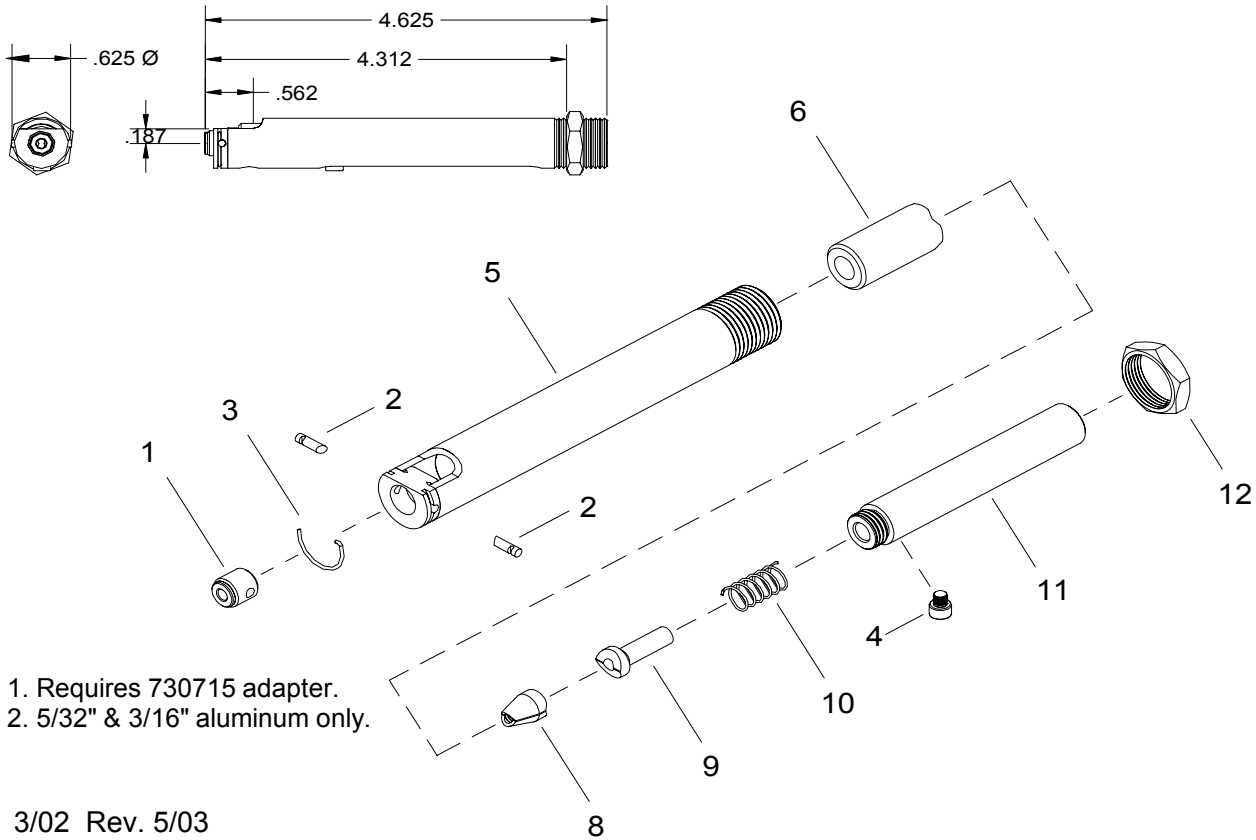

GAGE BILT

GAGE BILT Inc.

44766 Centre Court (586) 226-1500
 Clinton Twp., MI 48038 (586) 226-1505 Fax
 e-mail:solutions@gagebilt.com / www.gagebilt.com

Type:		Fasteners:	Recommended Tool:
Non Self-Releasing 1/8", 5/32" & 3/16" Ø		CHERRYMAX®, CHERRYMAX® 'AB', MBC® LOCK CREATOR BACR15FR/FP, BACR15GF/GK, NAS1900 S & U SERIES BLIND RIVET WITH DRIVE WASHER	(2) GBP715C
			Alternate Tools: (2) GB51 & (1) GB751
Ref. No.	Qty.	Description	456MAX-715-43
1	1	Anvil - Driving	10386
2	2	Pin - Ratchet	15501
3	1	Spring Ratchet - Pin	50302
4	1	Screw	70303
5	1	Anvil Holder	10301
6	1	Collet	20513-2
7	1	Jaw Assembly (Inc. 8-10)	30513-F1
8	1	Jaw Set	30513
9	1	Follower	40506
10	1	Spring	50301
11	1	Drawbolt	70301
12	1	Locknut	70411