

NOSE ASSEMBLY DATA SHEET

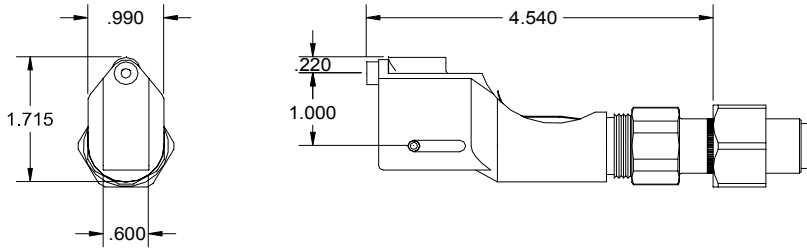

Screw drawbolt adapter (10) onto head piston of tool one to two turns. Screw frame adapter (11) into front of head cylinder until drawbolt saddle comes into contact with the front of the frame. When installing the nose assembly rivet pintail may be inserted into the nose assembly to insure proper adjustment. For optimal installation, pintail should be engaged when inserted into the nose. Rotate nose assembly to desired position and tighten retaining nut on frame adapter assembly (11) securely. With tool connected to air insert a pintail into the jaws to set position.

Disassembly:

Remove frame adapter (11) providing access to drawbolt adapter (10). Remove drawbolt adapter, use wrench to loosen. Remove guard (5) and roll pin (8) allowing drawbolt and jaw assembly to be lifted out of frame (9). Remove dowel pin (2) and roll pin (3) and dismantle jaw assembly.

Assembly:

Reverse procedure. Insert spring (6) and jaw (4) into drawbolt (7). Place saddle (1) onto drawbolt and install dowel (2) and roll pin (3). Place drawbolt and jaw subassembly into frame (9) and install roll pin (8) and guard (5).

Use Loctite® #242 or equivalent when assembling drawbolt adapter and drawbolt, and when assembling frame adapter to frame.

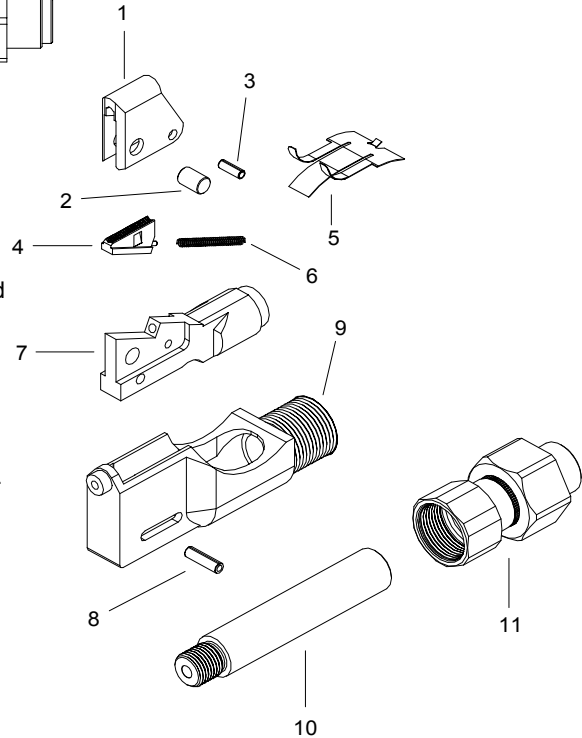

5/07 Rev 8/07

GAGE BILT
MADE IN U.S.A.

GAGE BILT Inc.

44766 Centre Court (586) 226-1500
Clinton Twp. MI 48038 (586) 226-1505 Fax
e-mail:solutions@gagebilt.com / www.gagebilt.com

Type:		CHERRYMAX®, CHERRYMAX® 'AB', MBC® LOCK CREATOR BACR15FR/FP, BACR15GF/GK, NAS1900 S & U SERIES BLIND RIVET WITH DRIVE WASHER	Recommended Tool(s):
Non Self-Releasing 1/8", 5/32" & 3/16" Ø			GB722, GB731 GB751 & GB752
Ref. No.	Qty.	Description	456MAX-731-43OS
1	1	Drawbolt Saddle	78201
2	2	Dowel Pin	76302
3	1	Roll Pin	78103
4	1	Jaw	78104
5	1	Guard	76305
6	1	Spring	76306
7	1	Drawbolt	78207
8	1	Roll Pin	76308
9	1	Frame	76309
10	1	Drawbolt Adapter	70469
11	1	Frame Adapter	70460