

NOSE ASSEMBLY DATA SHEET

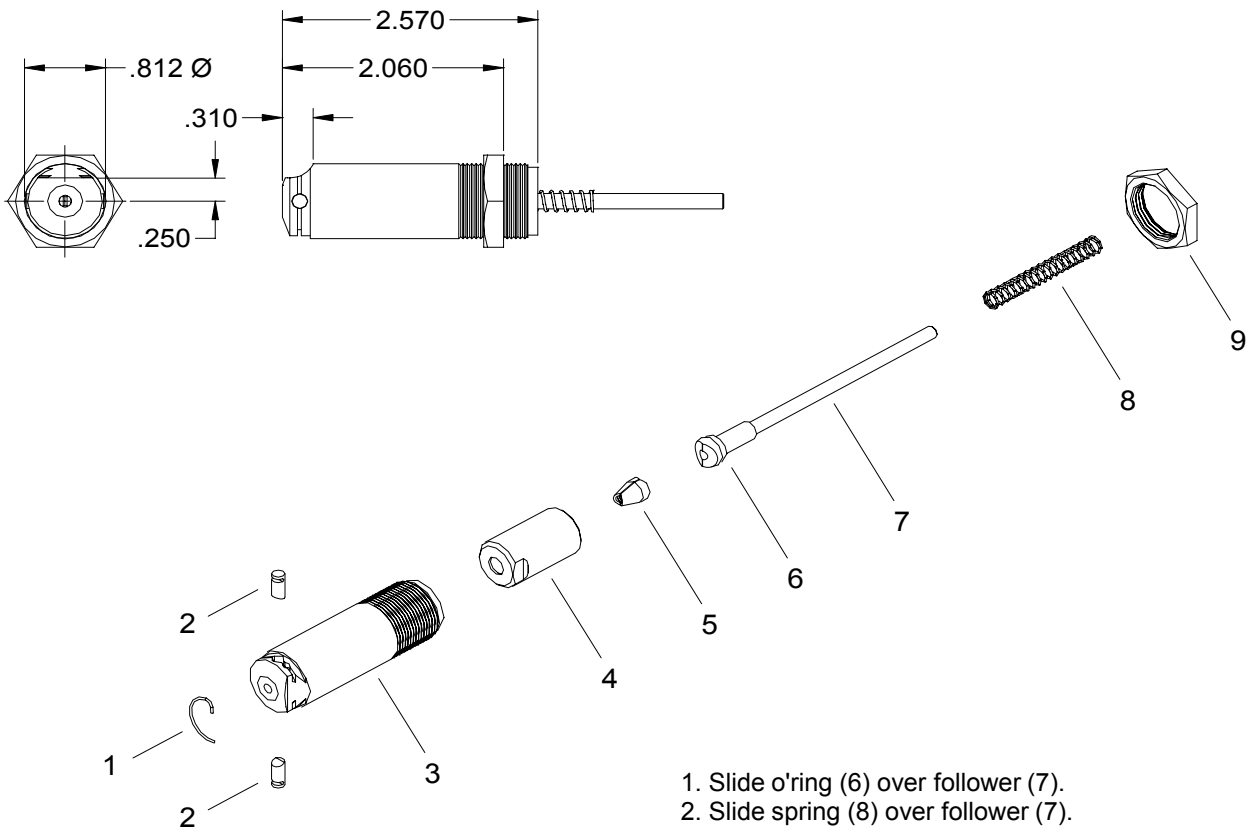

1. Slide o'ring (6) over follower (7).
2. Slide spring (8) over follower (7).
3. Place jaws (5) inside collet (4). Insert follower (7) inside collet (4) against jaws (5). Screw this assembly onto end of head piston. Tighten securely, using wrenches on flats provided.
4. Thread anvil (3), which contains jam nut (9) snugly into end of head cylinder. Tighten jam nut securely.

Rev. 1/03

GAGE BILT

GAGE BILT Inc.

44766 Centre Court (586) 226-1500
 Clinton Twp. MI 48038 (586) 226-1505 Fax
 e-mail:solutions@gagebilt.com / www.gagebilt.com

Type:		Fastener:		Recommended Tool: GBP744E
Non Self-Releasing 1/8", 5/32" & 3/16" Ø		CHERRYMAX®, CHERRYMAX® 'AB', MBC® LOCK CREATOR BACR15FR/FP, BACR15GF/GK, NAS1900 S & U SERIES BLIND RIVET WITH DRIVE WASHER		
Ref. No.	Qty.	Description	456MAX-744-20	
1	1	Retaining Ring	70101	
2	2	Stem Stop	70102	
3	1	Anvil	10436	
4	1	Collet	20403	
5	1	Jaw Set	30513	
6	1	O'Ring	A-720	
7	1	Follower Assembly	40403	
8	1	Spring	50806	
9	1	Jam Nut	70821	