

NOSE ASSEMBLY DATA SHEET

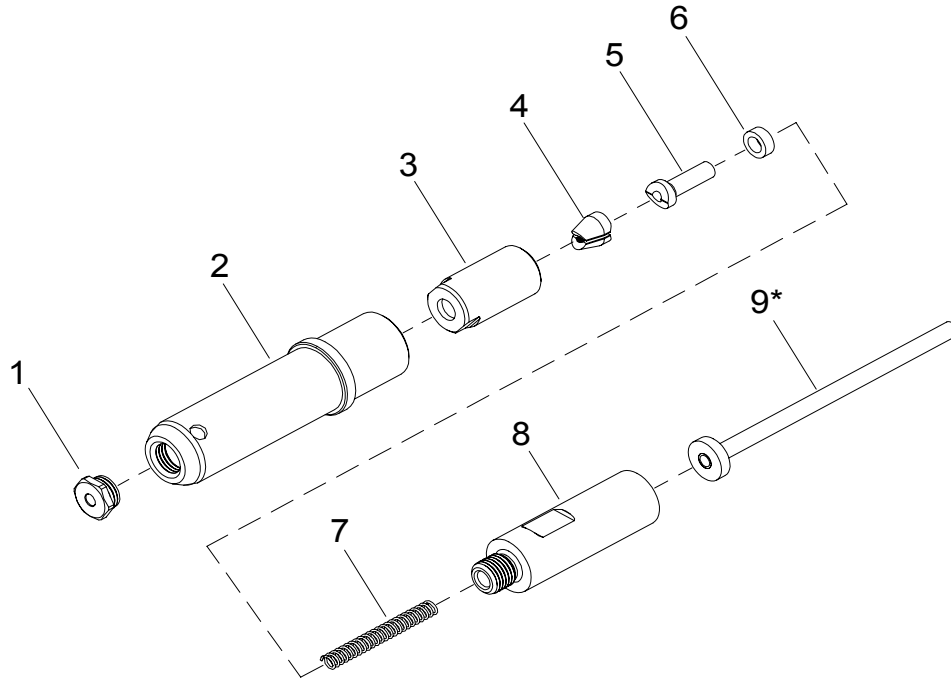
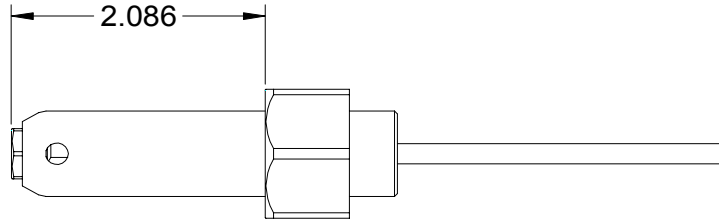
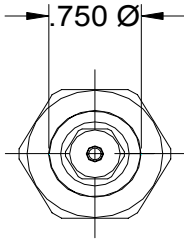

Use Hex-Key in rear of piston for nose assembly attachment.

*Remove for -6 Intermax.

11/06 Rev. 7/10

GAGE BILT
MADE IN U.S.A.

GAGE BILT Inc.

44766 Centre Court (586) 226-1500
Clinton Twp. MI 48038 (586) 226-1505 Fax
e-mail: solutions@gagebilt.com / www.gagebilt.com

Type:		Fastener:		Recommended Tool:
Non Self-Releasing 1/8", 5/32" & 3/16" Ø		CHERRYMAX®, CHERRYMAX® 'AB', MBC® LOCK CREATOR BACR15FR/FP, BACR15GF/GK, NAS1900 S & U SERIES BLIND RIVET WITH DRIVE WASHER		GB752
				Alternate Tools: GB751 & GBP2480(A)
Ref. No.	Qty.	Description	456MAX-751A-21	
1	1	Nose Tip	10206-1	
2	1	Anvil-Holder	10942-4	
3	1	Collet	70105	
4	1	Jaw Set	30513	
5	1	Follower	40506	
6	1	Bumper	70108	
7	1	Spring	70109	
8	1	Collet Extension	70466	
9*	1	Pintail Tube	40446	