

NOSE ASSEMBLY DATA SHEET

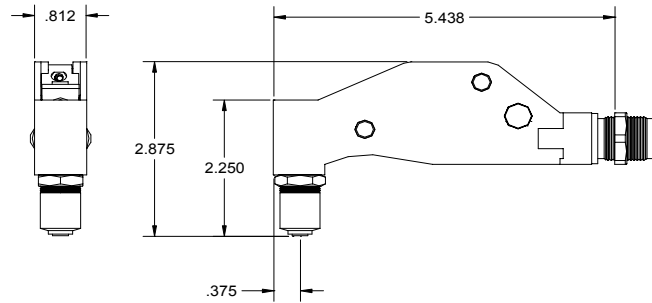

*RECOMMENDED FOR MAINTENANCE APPLICATIONS ONLY.
 **RIGHT ANGLE NOSE ASSEMBLIES REQUIRE MORE THAN ONE "PULL".



3/08

GAGE BILT GAGE BILT PRODUCTS CORP.

14500 Barber Drive (586) 771-7664
 Warren, Mi 48088 (586) 771-2665 Fax
 e-mail:solutions@gagebilt.com / www.gagebilt.com

Type:	Fasteners:	Recommended Tool:
Self-Releasing Front Ejecting 1/8", 5/32" & 3/16" Ø	Single Action Blind Rivet NAS1919U & NAS1921U NAS9301-NAS9312 M7885 BACR15FP/FR BACR15GF/GK	GBP704E

Ref. No.	Qty.	Description	456MAX-753A-54
1	1	Sleeve	10420
2	1	Jam Nut	70411
3	1	Collet	20513
4	1	Jaw Set	30513
5	1	Follower	40557
6	1	O'Ring	400774
7	1	Spring	50505
8	1	Stem Stop	70408
9	2	O'Ring	A-1034
10	1	Frame	75310
11	2	Shoe Bearing	75311
12	1	Collet Bolt	75312
13	1	Lever	75313
14	1	But. Hd Screw	402471
15	2	Set Screw	75315
16	1	Guard	75316
17	2	Pivot Pin	75317
18	8	Link	75318
19	4	Link Pin	75319
20	1	Bell Crank	75320
21	1	Guide Pin	75321
22	1	Drawbolt	75322
23	1	Adapter Fitting	75323
24	1	Jam Nut	70104

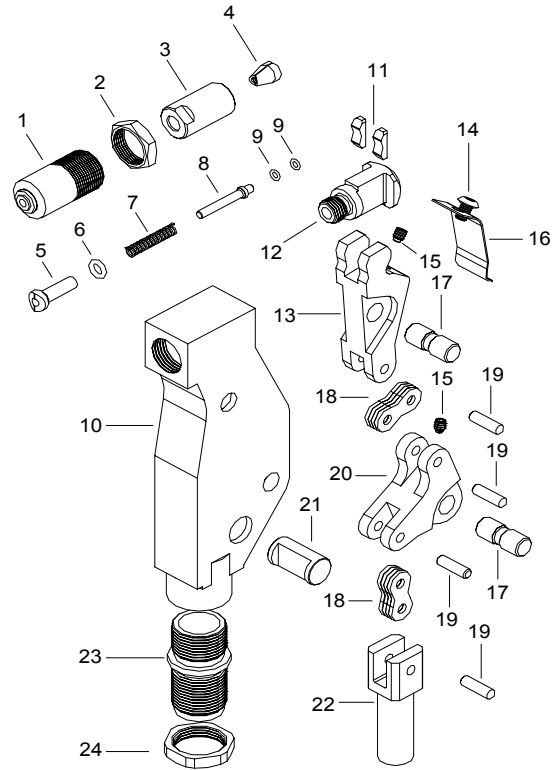

Engage 1 or 2 threads of drawbolt (22) onto head piston, then insert adapter fitting (23) into end of head cylinder and turn clockwise until snug. Rotate nose assembly to desired position and tighten jam nut (24) securely.

After attaching the nose assembly to the riveter, adjust sleeve (1) by loosening jam nut (2), then insert largest diameter rivet to be installed in sleeve and rotate sleeve until jaws just grab pintail. Tighten jam nut (2) securely. By this sleeve adjustment, the nose assembly can be made to release or to hold the pintail after installation.

DISASSEMBLY AND ASSEMBLY

Disassembly:

Loosen jam nut (2) and remove sleeve (1). Unscrew collet (3) which contains jaws (4), follower (5), o'ring (6), spring (7), stem stop (8) and o'rings (9) from collet bolt (12).

Remove screw (14) and guard (16). Remove 2 set screws (15) and push out 2 pivot pins (17) to permit removal of linkage. Shoe bearings (11) and collet bolt (12) will disengage from lever (13).

Remove 4 link pins (19) to disassemble lever (13), links (18), bell crank (20) and drawbolt (22).

Remove guide pin (21) from frame (10). Adapter fitting (23) is secured to frame with loctite and need not be removed unless damaged.

Reassembly:

Reverse the procedure. Linkage, consisting of lever (13), links (18), bell crank (20) and drawbolt (22) should be assembled as a subassembly before inserting lever (13) into shoe bearings (11) and collet bolt (12). This complete subassembly may then be inserted into frame (10) and retained by guide pin (21) and pivot pins (17).