

NOSE ASSEMBLY DATA SHEET

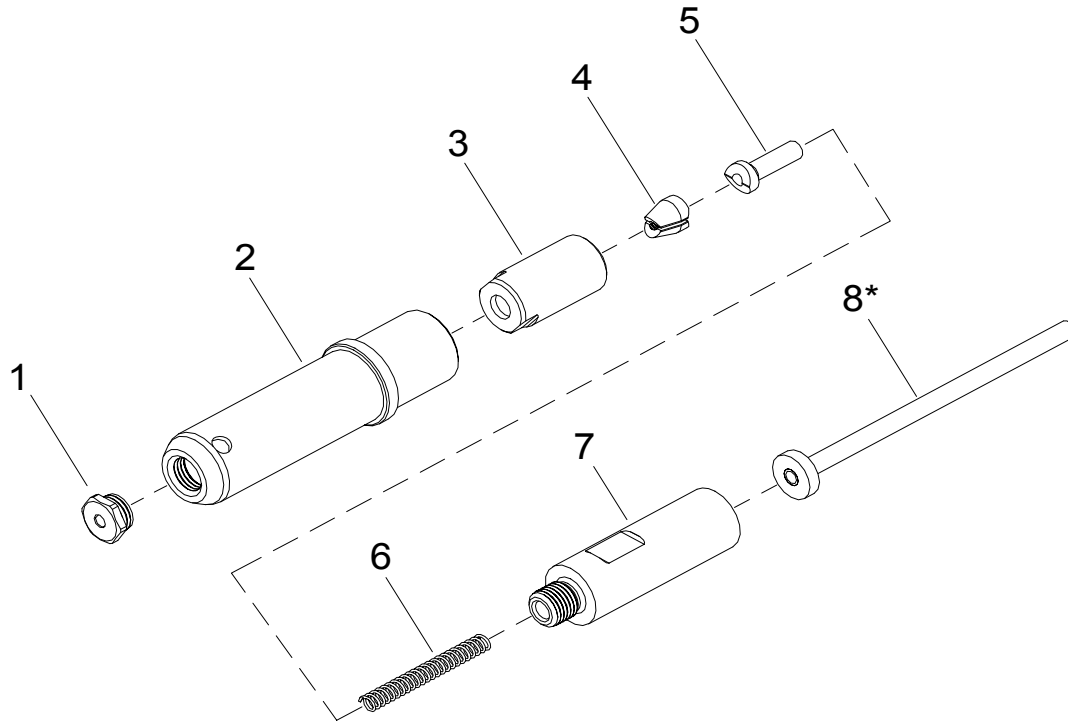
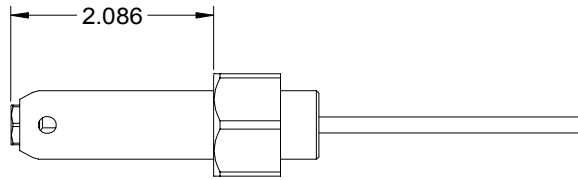
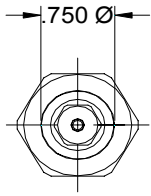

Use Hex-Key in rear of piston
for nose assembly attachment.

*Remove for -6 NAS1919/21 U.

1/08 Rev. 12/08

GAGE BILT
MADE IN U.S.A.

GAGE BILT Inc.

44766 Centre Court (586) 226-1500
Clinton Twp. MI 48038 (586) 226-1505 Fax
e-mail:solutions@gagebilt.com / www.gagebilt.com

Type:		Fastener:	Recommended Tool: GB752
Non Self-Releasing 1/8", 5/32" & 3/16" Ø		NAS1919 & NAS1921 "U" TYPE BLIND RIVET WITH DRIVE WASHER	Alternate Tools: GB751 & GB2480(A)
Ref. No.	Qty.	Description	456UBR-751A-21
1	1	Nose Tip	10206-1
2	1	Anvil-Holder	10942-4
3	1	Collet	70105
4	1	Jaw Set	30513
5	1	Follower	40506-1
6	1	Spring	50316
7	1	Collet Extension	70466
8*	1	Pintail Tube	40446