

NOSE ASSEMBLY DATA SHEET

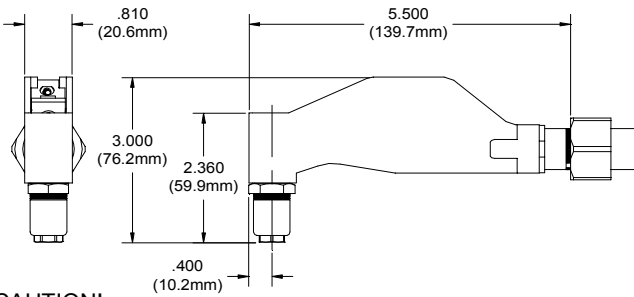

CAUTION!

Pintails may eject forcibly. This nose is for closed access applications. If used in open access applications, 704214 catcher bag is recommended TO PREVENT SEVERE PERSONAL INJURY.

- *GBP722A USE 722142 STROKE LIMITER.
- **GBP752F USE 752142 STROKE LIMITER.
- ***GBP751D USE 751156 STROKE LIMITER.
- ****MOST FASTENERS REQUIRE MORE THAN ONE PULL.



9/10

GAGE BILT

GAGE BILT, INC.

44766 Centre Court (586) 226-1500
 Clinton Twp. MI 48038 (586) 226-1505 Fax
 e-mail:solutions@gagebilt.com / www.gagebilt.com

Type:	Fasteners:	Recommended Tool: ***GB751
Single Action 3/16" Ø	Plastic Split	Alternate Tool: *GB722 & **GB752

Ref. No.	Qty.	Description	6P-751C-54RA
1	1	Nose Tip	10167
2	1	Sleeve	10125
3	1	Jam Nut	70411
4	1	Collet	20327
5	1	Jaw Set	30311-1
6	1	Follower	40304-2
7	1	Spring	50627
8	1	Frame	75310
9	2	Shoe Bearing	75311
10	1	Collet Bolt	70443-2
11	1	Lever	75313
12	1	But. Hd Screw	402471
13	2	Set Screw	75315
14	1	Guard	75316
15	2	Pivot Pin	75317
16	8	Link	75318
17	4	Link Pin	75319
18	1	Bell Crank	75320
19	1	Guide Pin	75321
20	1	Drawbolt	75322
21	1	Adapter Assembly	70459
22	1	Collet Extension	70463

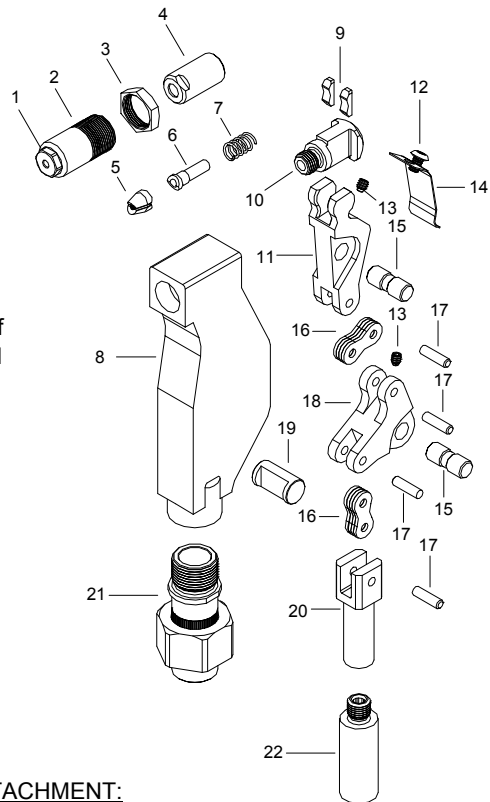

ATTACHMENT:

Screw collet adapter (22) onto head. Insert adapter assembly (21) into nose adapter and hand tighten nut. Nose assembly should rotate if stop is properly aligned when tightening. Hold finger at rear of collet bolt (10) and screw nose tip & sleeve assembly down until pintail moves freely in & out.

DISASSEMBLY:

Loosen jam nut (3) and remove sleeve (2). Unscrew collet (4) which contains jaws (5), follower (6), and spring (7) from collet bolt (10).

Remove screw (12) and guard (14). Remove 2 set screws (13) and push out 2 pivot pins (15) to permit removal of linkage. Shoe bearings (9) and collet bolt (10) will disengage from lever (11).

Remove 4 link pins (17) to disassemble lever (11), links (16), bell crank (18) and drawbolt (20).

Remove guide pin (19) from frame (8). Adapter fitting (21) is secured to frame with Loctite® and need not be removed unless damaged.

REASSEMBLY:

Reverse the procedure. Linkage, consisting of lever (11), links (16), bell crank (18) and drawbolt (20) should be assembled as a subassembly before inserting lever (11) into shoe bearings (9) and collet bolt (10). MAKE SURE NOTCHES ON COLLET BOLT (10) ARE POINTING TOWARDS LEVER (11). This complete subassembly may then be inserted into frame (8) and retained by guide pin (19) and pivot pins (15).