

751204 ADAPTER DATA SHEET

To attach adapter and nose to tool:

1. Remove nose assembly nut from nose drawbar.
2. Place adapter nut (3) into threaded end of collet with thread forward as shown. Thread collet adapter (2) onto head piston.
3. With collet placed in nose assembly anvil, tighten both onto anvil adapter assembly (1).
4. Slide anvil adapter (1) over collet adapter (2) and lock into place on tool. Slide drawbar into nose assembly thru adapter assembly.
5. Using tee-wrench (4) thru rear of installation tool and 1/4" allen wrench on front of nose assembly drawbar tighten nut to drawbar.

CAUTION

Pintail may eject forcibly.
Used for closed access applications only to prevent severe personal injury!

To remove adapter and nose from tool
reverse assembly instructions

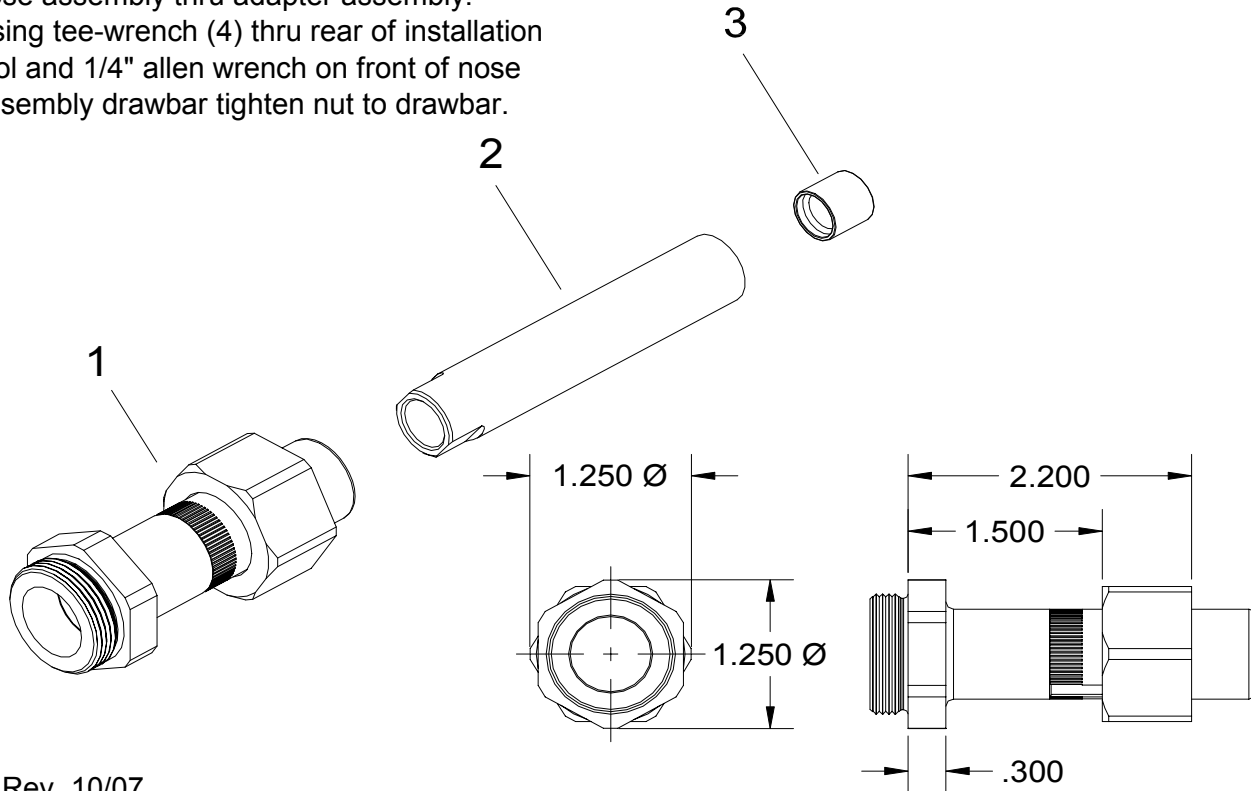

3/03 Rev. 10/07

GAGE BILT

GAGE BILT Inc.

44766 Centre Court (586) 226-1500
Clinton Twp. MI 48038 (586) 226-1505 Fax
e-mail:solutions@gagebilt.com / www.gagebilt.com

Type:

Rotatable
Offset Nose Assembly
Adapter

Adapts GB204 Series Nose Assemblies to:
GB722, GB731, GB751 Installation Tools

Ref. No.	Qty.	Description	751204
1	1	Anvil Adapter Assembly	352218
2	1	Collet Adapter	352210
3	1	Nut	352211
4	1	Tee-Wrench	A-291