

# NOSE ASSEMBLY DATA SHEET

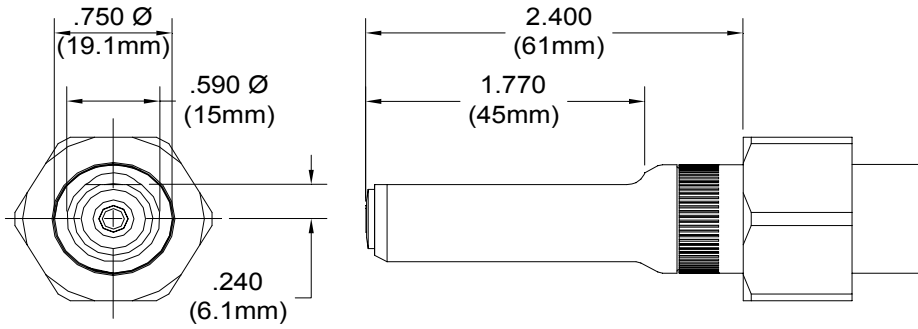

Use Hex-Key in rear of piston  
For nose assembly attachment

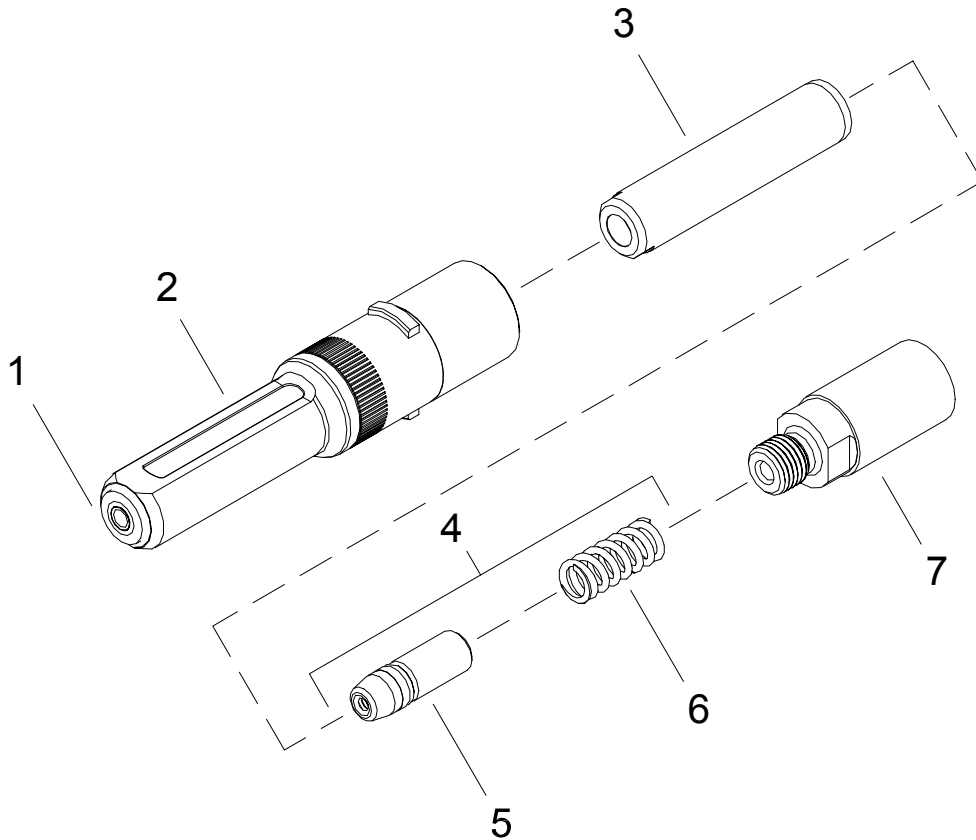

4/05

\*Anvil Assembly includes 35208 retainer.

## GAGE BILT

## GAGE BILT PRODUCTS CORP.

14500 Barber Drive (586) 771-7664  
Warren, Mi 48088 (586) 771-2665 Fax  
e-mail:solutions@gagebilt.com / www.gagebilt.com

Type: Self-Releasing		Fastener: NAS1398A/1399A NAS1738A/1739A RV1000/1100 & 1200	Recommended Tool: GBP752D			
3/32", 1/8", 5/32" and 3/16" Ø			Alternate Tools: GBP751B, GBP713B & GBP2400B			
Ref. No.	Qty.	Description	3A- 352B-25	4A- 352B-25	5A- 352B-25	6A- 352B-25
1	1	Anvil-Driving	10362	10427	10560	10657
2	1	Anvil & Holder Assembly (Inc. #1)	19943	19944	19945	19946
3	1	Collet	20502	20502	20502	20502
4	1	Jaw Assembly (Inc. 5 & 6)	30301-M3	30406-M6	30511-M7	30610-M7
5	1	Jaw Assembly	30301-M2	30406-M5	30511-M6	30610-M6
6	1	Spring	50401	50401	50401	50401
7	1	Collet Extension	70501	70501	70501	70501