

NOSE ASSEMBLY DATA SHEET

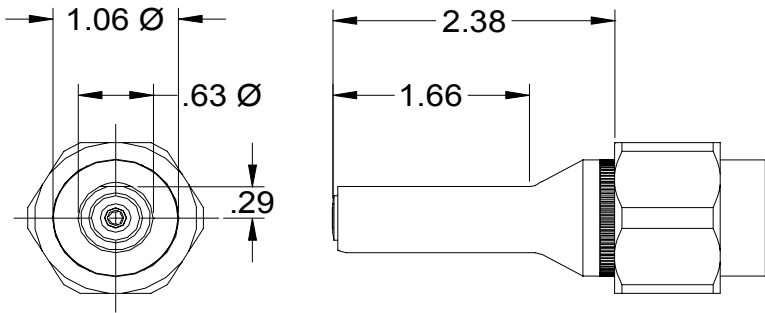

Use Hex-Key in rear of piston for nose assembly attachment.

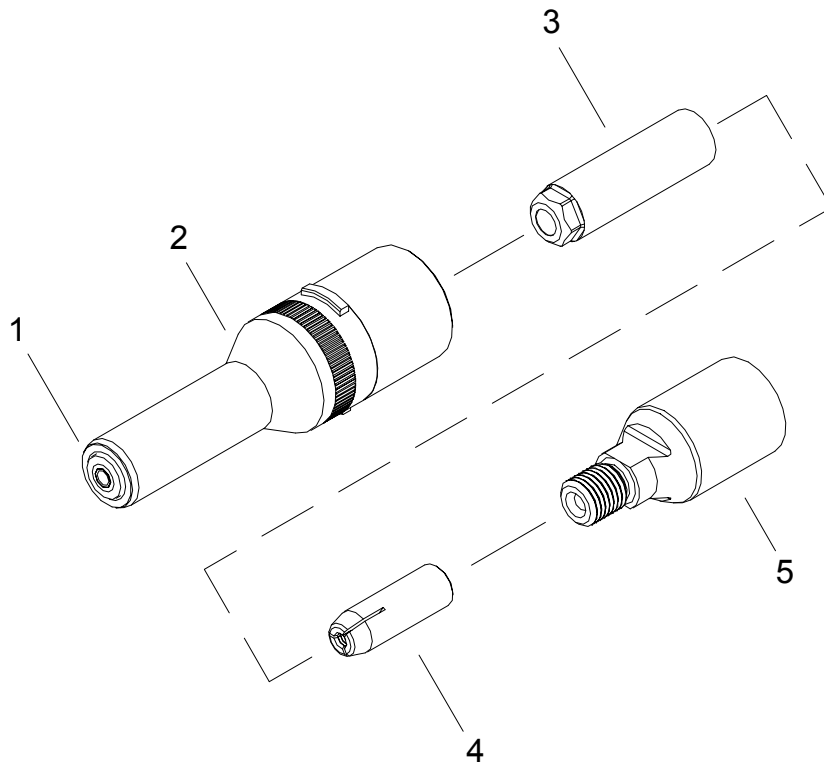

8/03

GAGE BILT

GAGE BILT Inc.

44766 Centre Court (586) 226-1500
 Clinton Twp., MI 48038 (586) 226-1505 Fax
 e-mail:solutions@gagebilt.com / www.gagebilt.com

Type:		Fastener:		Recommended Tool: GBP745D	
Non Self-Releasing 1/8", 5/32" & 3/16" Ø		NAS1398A/NAS1399A RV1000/RV1100 & RV1200		Alternate Tools: GBP4801B & GBP4804	
Ref. No.	Qty.	Description	4A-745B-23	5A-745B-23	6A-745B-23
1	1	Anvil Insert	10427	10560	10657
2	1	Anvil Assembly (Includes #1)	13302	13303	13304
3	1	Collet	20717	20717	20717
4	1	Super-Grip Jaw Assembly	30425-S	30545-S	30656-S
5	1	Collet Extension	70552	70552	70552