

# NOSE ASSEMBLY DATA SHEET

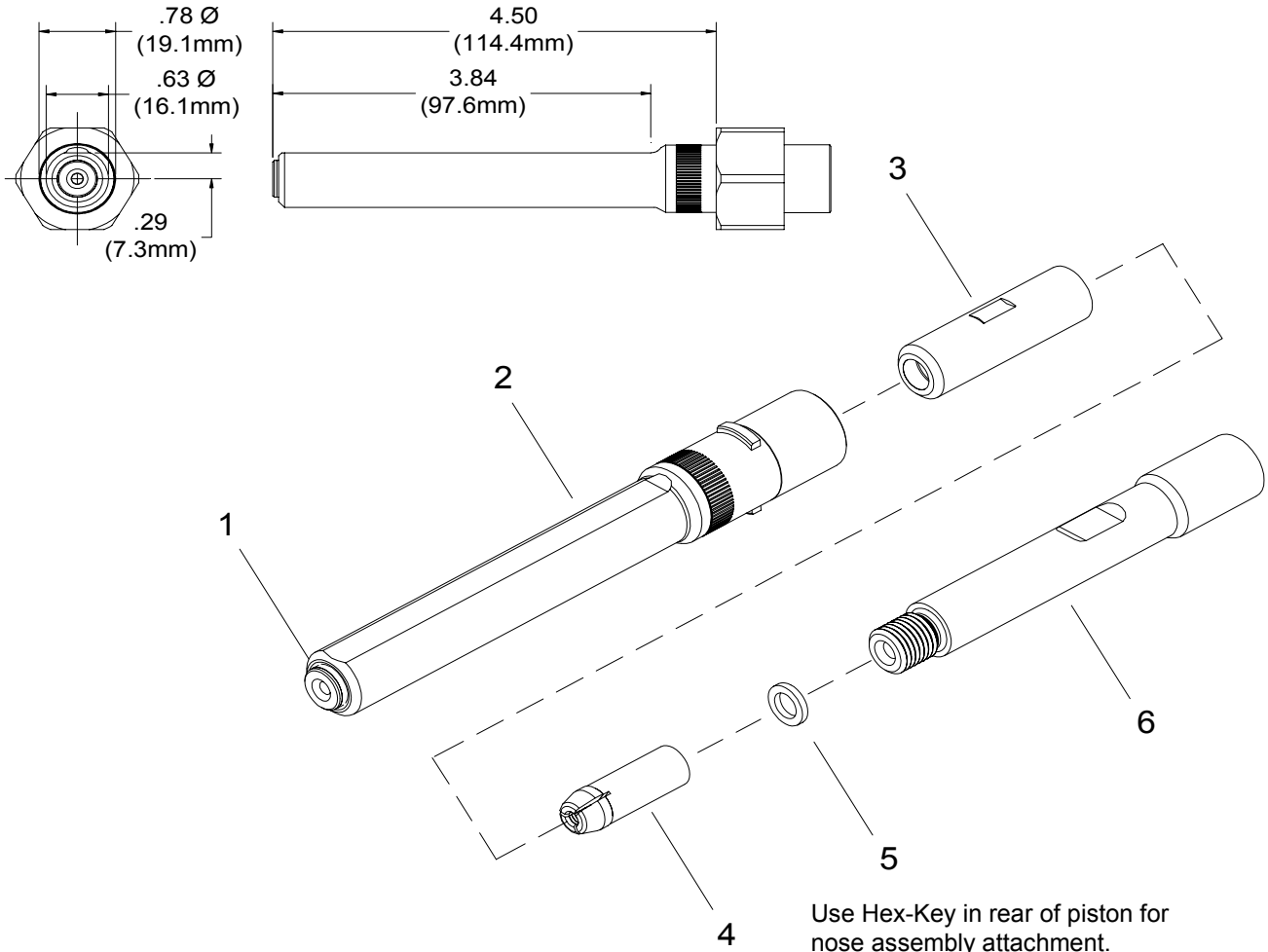

\*Anvil Assembly consists of #1 and 35208 retainer.

1/12

**GAGE BILT**  
MADE IN U.S.A.

**GAGE BILT Inc.**

44766 Centre Court (586) 226-1500  
Clinton Twp., MI 48038 (586) 226-1505 Fax  
e-mail:solutions@gagebilt.com / www.gagebilt.com

Type:		Fastener:		Recommended Tool:	
Non Self-Releasing 1/8, 5/32 & 3/16 Ø		NAS1398A/1399A RV1000/1100 & 1200		GB752	
				Alternate Tools: GB751 & GB2480	
Ref. No.	Qty.	Description	4A-752C-45	5A-752C-45	6A-752C-45
1	1	Anvil-Driving	10427	10560	10657
2	1	Anvil & Holder Assy.	17763	17764	17765
2a	1	(Includes #1)			
3	1	Collet	20727	20727	20727
4	1	Super-Grip Jaw Assembly	30425-CS	30545-CS	30656-CS
5	1	Spacer	70572	70572	70572
6	1	Collet Extension	70551	70551	70551