

NOSE ASSEMBLY DATA SHEET

Use Hex-Key in rear of piston for nose assembly attachment.

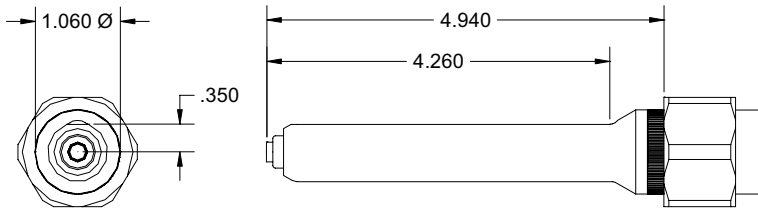

NOTE!
Use with driver:
ASP-06 for 13/64 dia.
ASP-08 for 17/64 dia.
asp-10 for 21/64 dia.

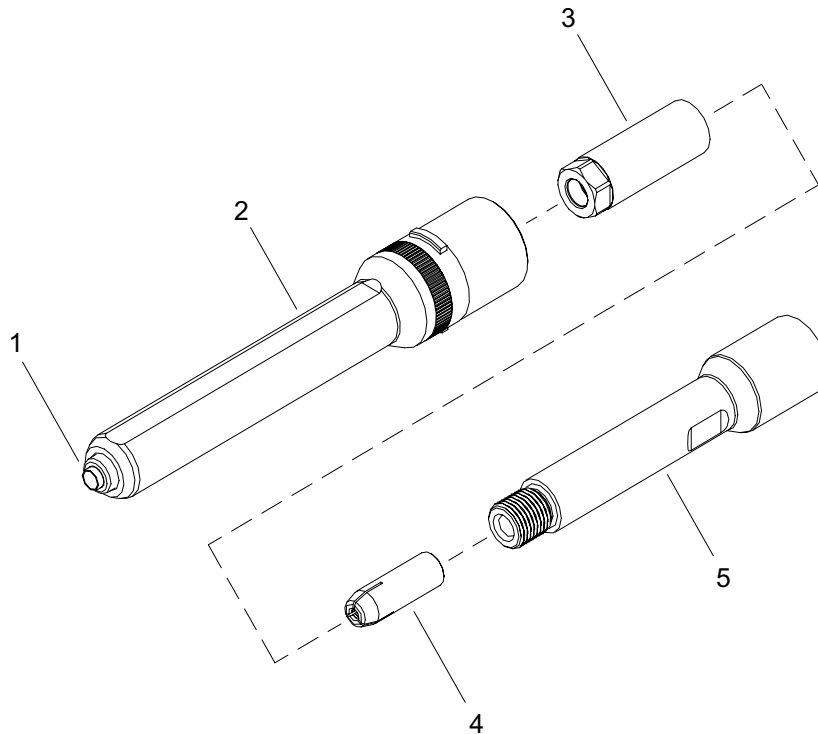

*Anvil Assembly includes 35308 retainer.
**ASP10 for maintenance and close clearance applications. Use ASP10-745C-48 for high production applications.

10/01 Rev. 4/08

GAGE BILT

GAGE BILT PRODUCTS CORP.

44766 Centre Court (586) 226-1500
Clinton Twp, Mi 48038 (586) 226-1505 Fax
e-mail:solutions@gagebilt.com / www.gagebilt.com

Type:		Fastener:		Recommended Tool:	
Non Self-Releasing 13/64", 17/64" & 21/64" Ø		2 ASP, ASP PF, ASP FF ASP F & ASP LC		GBP745B	
				Alternate Tools: GBP4801 & GBP4804	
Ref. No.	Qty.	Description	ASP06-745B-48	ASP08-745B-48	**ASP10-745B-48
1	1	Cap Assembly	10142	10143	10174
2	1	Anvil & Holder Assy. (Inc.#1)	11181	11182	11183
3	1	Collet	20717	20717	20717
4	1	Super-Grip Jaw Assembly	30656-S	30864-S2	30863-S
5	1	Collet Extension	70553	70553-1	70553-1