

NOSE ASSEMBLY DATA SHEET

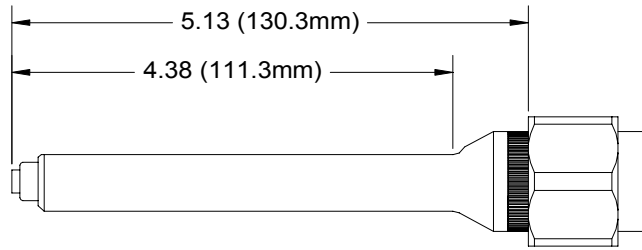

Use Hex-Key in rear of piston for nose assembly attachment.

NOTE:
Use with driver:
ASP-06 for 13/64 dia.
ASP-08 for 17/64 dia.

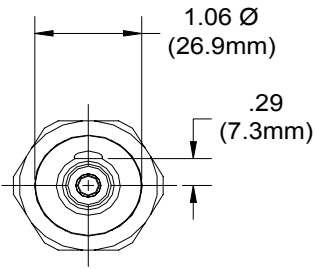
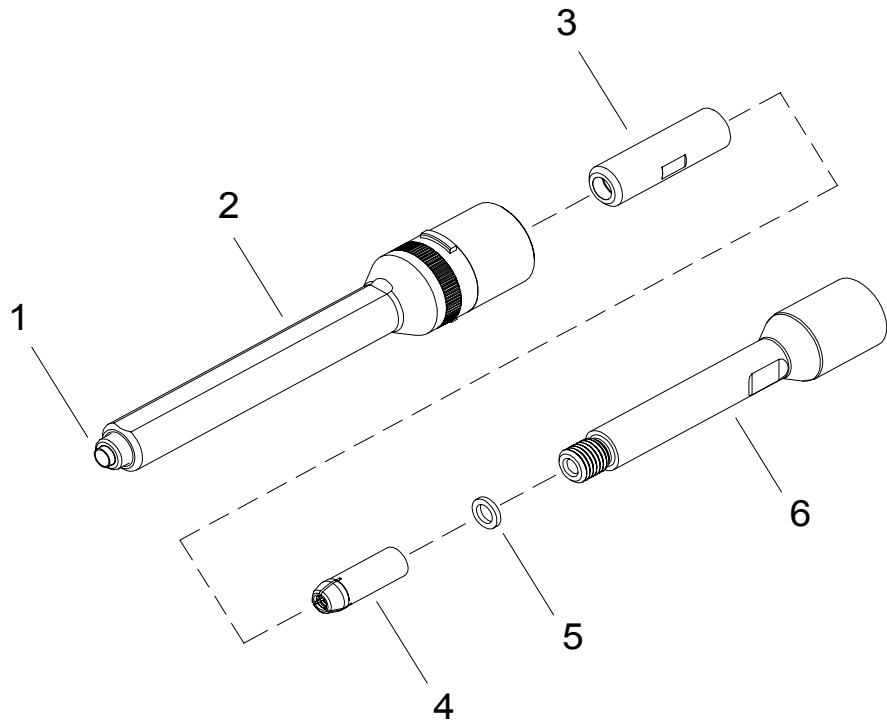

*Anvil Assembly includes 35308 retainer.



1/12

GAGE BILT
MADE IN U.S.A.

GAGE BILT Inc.

44766 Centre Court (586) 226-1500
Clinton Twp., MI 48038 (586) 226-1505 Fax
e-mail:solutions@gagebilt.com / www.gagebilt.com

Type:		Fastener:	Recommended Tool: GB745	
Non Self-Releasing 13/64" & 17/64"Ø		2 ASP®, ASP PF, ASP FF ASP F & ASP LC	Alternate Tools: GBP4801B & GBP4804	
Ref. No.	Qty.	Description	ASP06-745C-48	ASP08-745C-48
1	1	Cap Assembly	10142	10143
2	1	Anvil & Holder Assy. (Inc.#1)	11181	11182
3	1	Collet	20727	20727
4	1	Super-Grip Jaw Assembly	30656-CS	30864-CS
5	1	Spacer	70572	70572
6	1	Collet Extension	70553	70553-1