

NOSE ASSEMBLY DATA SHEET

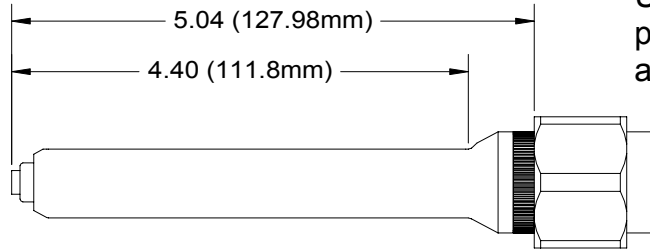

Use Hex-Key in rear of piston for nose assembly attachment.

NOTE:
Use with driver:
ASP-10 for 21/64 dia.

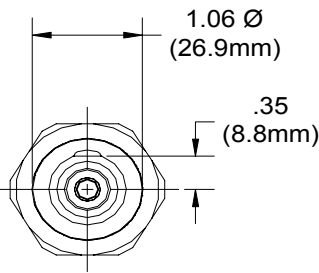
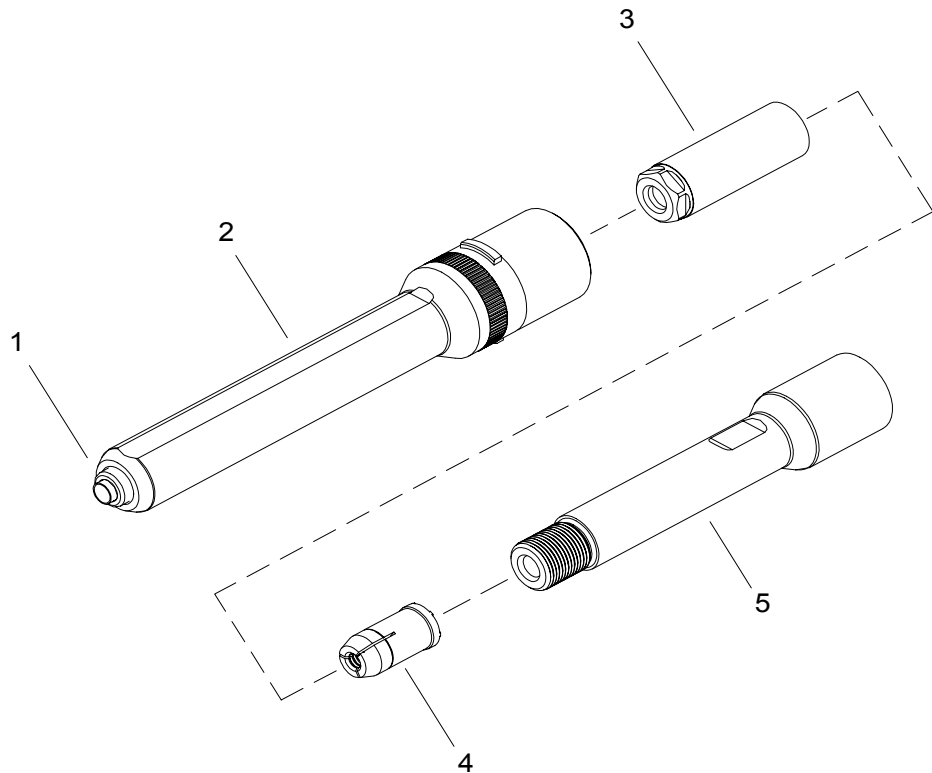

*Anvil Assembly includes 35308 retainer.

1/12

GAGE BILT

GAGE BILT Inc.

44766 Centre Court (586) 226-1500
Clinton Twp., MI 48038 (586) 226-1505 Fax
e-mail:solutions@gagebilt.com / www.gagebilt.com

Type:		Fastener:	Recommended Tool:
Non Self-Releasing 21/64" Ø		2 ASP®, ASP PF, ASP FF ASP F & ASP LC	GB745
			Alternate Tools: GBP4801B & GBP4804
Ref. No.	Qty.	Description	ASP10-755-48
1	1	Cap Assembly	10174
2	1	Holder Assembly (Inc. #1)	11193
3	1	Collet Extension	20841
4	1	Super-Grip Jaw Assembly	30865-S
5	1	Collet Extension	70642