

NOSE ASSEMBLY DATA SHEET

Use Hex-Key in rear of piston for nose assembly attachment.

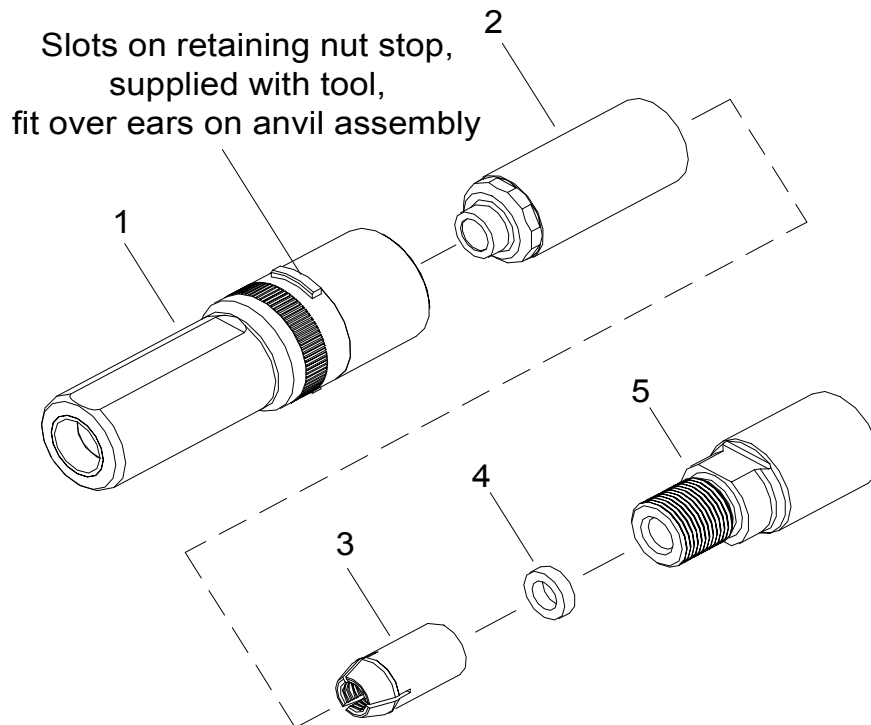

3/09

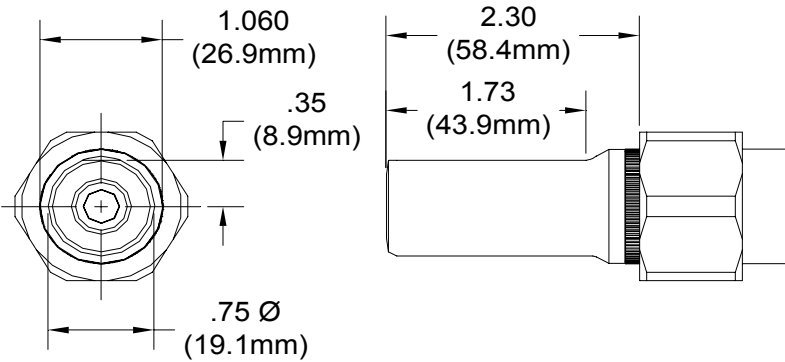

*Anvil Assembly includes 35308 retainer.

GAGE BILT

MADE IN U.S.A.

GAGE BILT Inc.

44766 Centre Court (586) 226-1500
 Clinton Twp., MI 48038 (586) 226-1505 Fax
 e-mail:solutions@gagebilt.com / www.gagebilt.com

Type:		Fasteners:	Recommended Tool: GB745
Non Self-Releasing 5/16 Ø		BL10	Alternate Tools: GBP4804
Ref. No.	Qty.	Description	BL10-755-23
1	1	Anvil	18801
2	1	Collet	28824-1
3	1	Super-Grip Jaw Assembly	30861-S1
4	1	Spacer	60835
5	1	Collet Extension	70836