

NOSE ASSEMBLY DATA SHEET

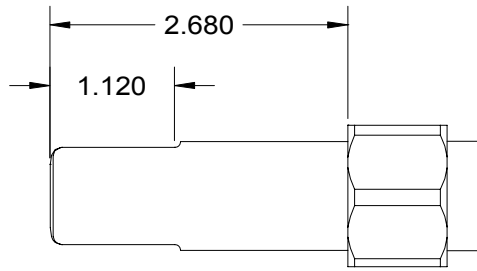

Use Hex-Key in rear of piston for nose assembly attachment.

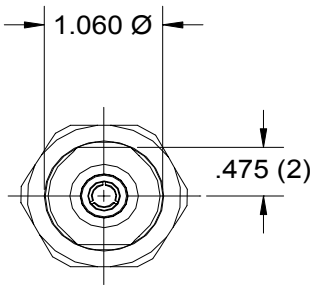
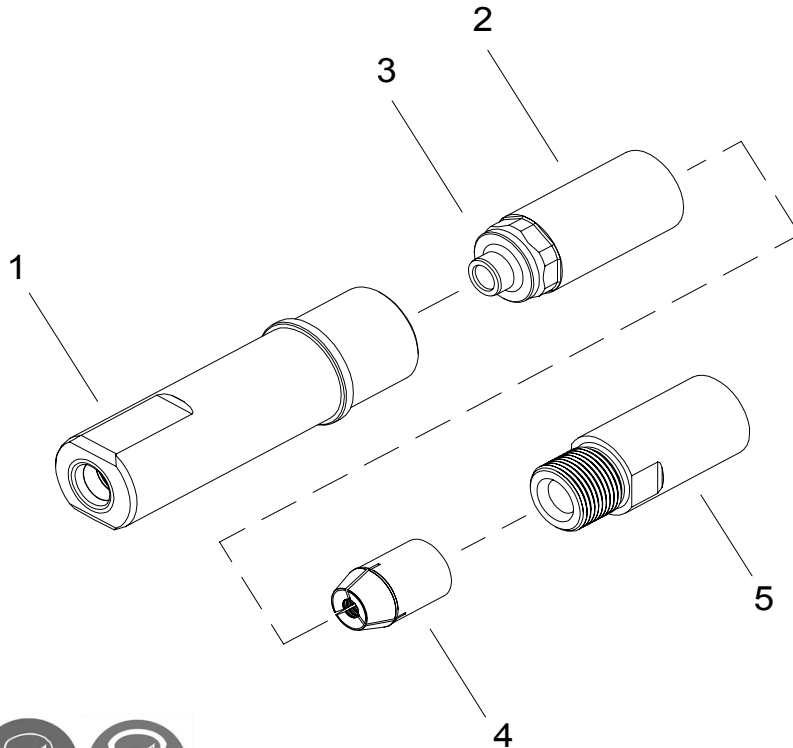

10/06

GAGE BILT
MADE IN U.S.A.

GAGE BILT Inc.

44766 Centre Court (586) 226-1500
Clinton Twp. MI 48038 (586)226-1505 Fax
e-mail:solutions@gagebilt.com / www.gagebilt.com

Type:		Fastener:	Recommended Tool: GB756
Non Self-Releasing 5/16 Ø		BOM®	Alternate Tools: GBP4801B & GBP4804
Ref. No.	Qty.	Description	BOM10-756-26
1	1	Anvil	11005
2	1	Collet Assembly (Includes #3)	21024
3	1	Ejector	81009-1
4	1	Super Grip Jaw Assembly	30869-S1
5	1	Collet Extension	71219

BOM® IS A REGISTERED TRADEMARK OF ALCOA INC.