

NOSE ASSEMBLY DATA SHEET

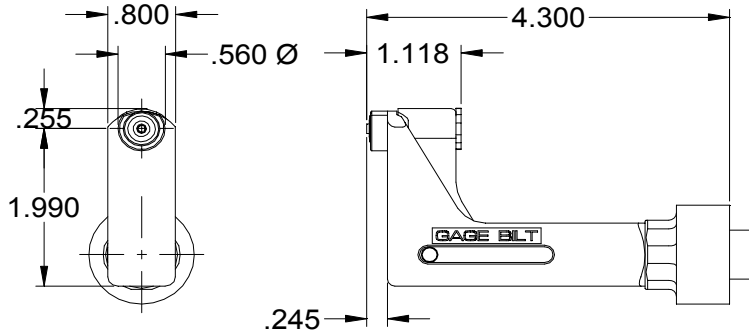

Attachment:

Screw on jam nut (70336) onto nose fitting of tool at least 3/4". Screw nose assembly onto nose fitting of tool until it stops then back off until nose is in desired position. (Warning: do not back off nose assembly more than one complete turn). Lock jam nut (70336) against adapter (70331).

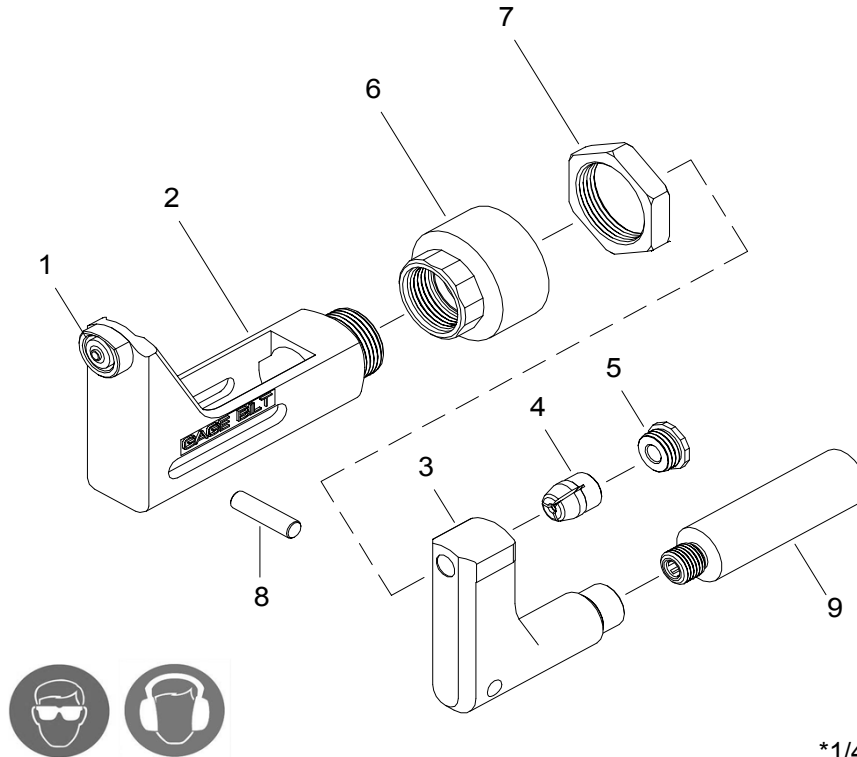

9/06 Rev. 3/07



*1/4" aluminum only

GAGE BILT
MADE IN U.S.A.

GAGE BILT Inc.

44766 Centre Court (586) 226-1500
Clinton Twp. MI 48038 (586) 226-1505 Fax
e-mail:solutions@gagebilt.com / www.gagebilt.com

Type:		Fasteners:				Recommended Tool: GB751	
Non Self-Releasing 1/8", 5/32", 3/16" & 1/4" Ø		NAS1919S NAS1921S				Alternate Tools: GB752, GB722 & GB2480	
Ref. No.	Qty.	Description	BR4-751A-430S	BR5-751A-430S	BR6-751A-430S	*BR8-751A-430S	
1	1	Anvil Insert	10426	10563	10684	10868	
2	1	Anvil & Holder Assembly (Inc. #1)	13357	13358	13359	13360	
3	1	Collet	20911	20911	20911	20911	
4	1	Super-Grip Jaw Assembly	30425-S2	30545-S4	30656-S3	30864-S5	
5	1	Cap	60428	60428	60428	60428	
6	1	Anvil Adapter	70331	70331	70331	70331	
7	1	Jam Nut	70336	70336	70336	70336	
8	1	Pin	70468	70468	70468	70468	
9	1	Collet Adapter	70332	70332	70332	70332	