

NOSE ASSEMBLY DATA SHEET

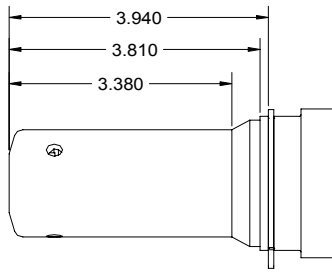

1. Ensure Piston is in full forward position.
2. Disconnect tool control cord.
3. Screw assembled Collet onto Piston until top of collet flat lines up with Adapter face of tool.
4. If Collet Lock (11) is not in Piston groove, continue to turn 1/4 turn, or less until lock engages groove.
5. Tighten Set Screw (12) on (new noses).
6. Slide Anvil (1) over assembled Collet. Install Split Ring, Sleeve (furnished with tool) and Retaining Ring (13).

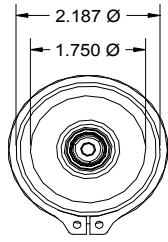
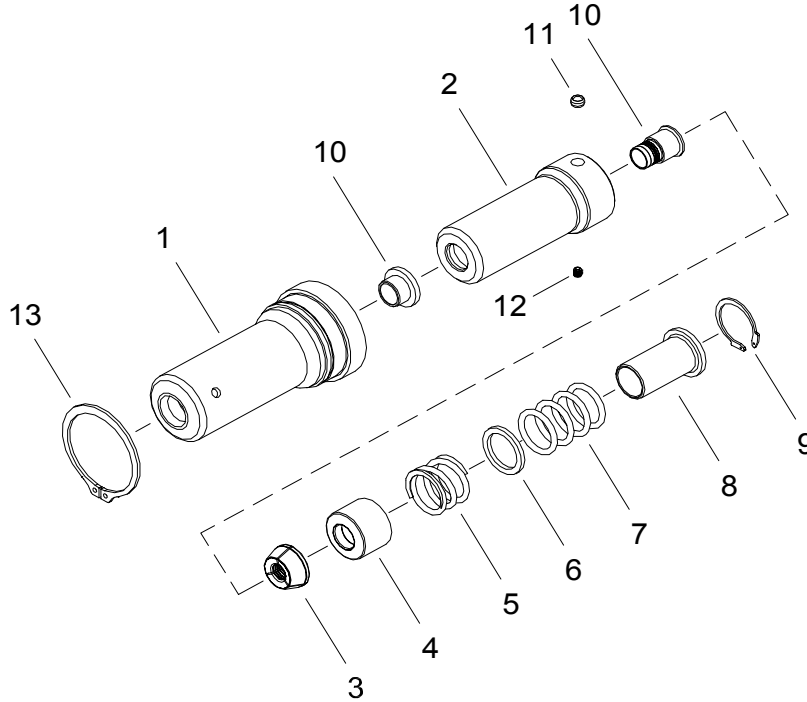

7/08 Rev 9/08

GAGE BILT
MADE IN U.S.A.

GAGE BILT Inc.

44766 Centre Court (586) 226-1500
Clinton Twp. MI 48038 (586) 226-1505 Fax
e-mail:solutions@gagebilt.com / www.gagebilt.com

Type:		Fastener:	Recommended Tool: GB7624(A)
Self-Releasing 1/2" Ø		HP8®	Alternate Tools: GB585, Model 585 or Model 586
Ref. No.	Qty.	Description	HP16-7624-40
1	1	Anvil Assembly	11625
2	1	Collet Assembly (Inc. 10,11 & 12)	21613
3	1	Jaw Set	31601
4	1	Follower	42003
5	1	Spring	52001
6	1	Spacer	55020
7	4	O'Ring	400846
8	1	Sleeve	62006
9	1	Retaining Ring	402263
10	1	Release & Ejector Kit	81600
11	1	Collet Lock	54502
12	1	Socket Set Screw	A-280
13	1	Retaining Ring	401027