

NOSE ASSEMBLY DATA SHEET

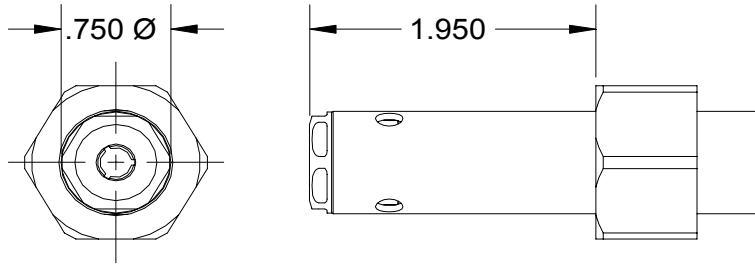

Use Hex-Key in rear of piston for nose assembly attachment.

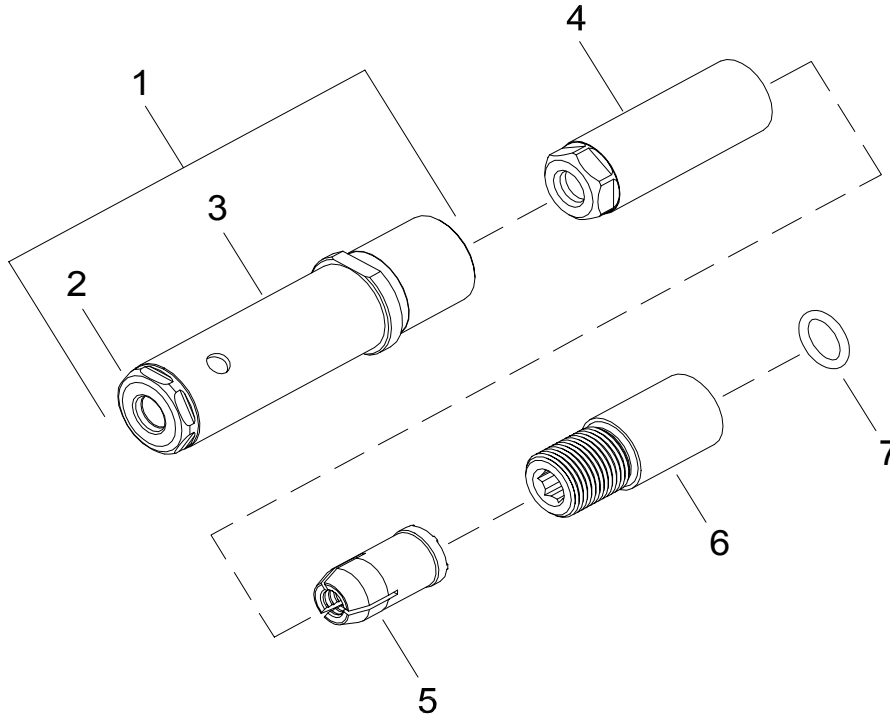

REV. 3/11

GAGE BILT
MADE IN U.S.A.

GAGE BILT Inc.

44766 Centre Court (586) 226-1500
Clinton Twp. MI 48038 (586) 226-1505 Fax
e-mail:solutions@gagebilt.com / www.gagebilt.com

Type:		Fasteners:		Recommended Tool: GB722	
Non Self-Releasing 3/16 & 1/4 Ø		Commercial Lockbolt C6L®, Avdelok®		Alternate Tools: GB731 & GB2480	
Ref. No.	Qty.	Description		LB06-722-20	LB08-722-20
1	1	Anvil & Holder Assembly		16002	18873
2	1	Anvil		16003	18874
3	1	Holder		12242-3	12242-2
4	1	Collet		20636	20841
5	1	Super-Grip Jaw Assembly		30653-CS	30861-CS
6	1	Extension		70823	70823
7	1	O'Ring		400778	400778