

# NOSE ASSEMBLY DATA SHEET

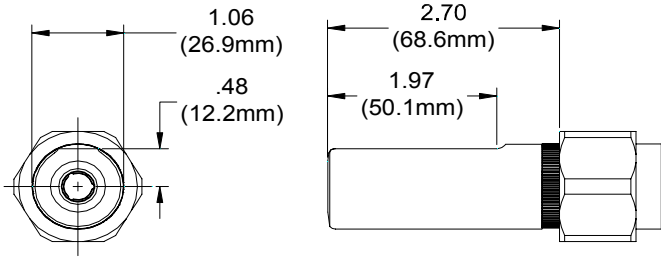

Use Hex-Key in rear of piston for nose assembly attachment.

Slots on retaining nut stop, supplied with tool, fit over ears on anvil assembly

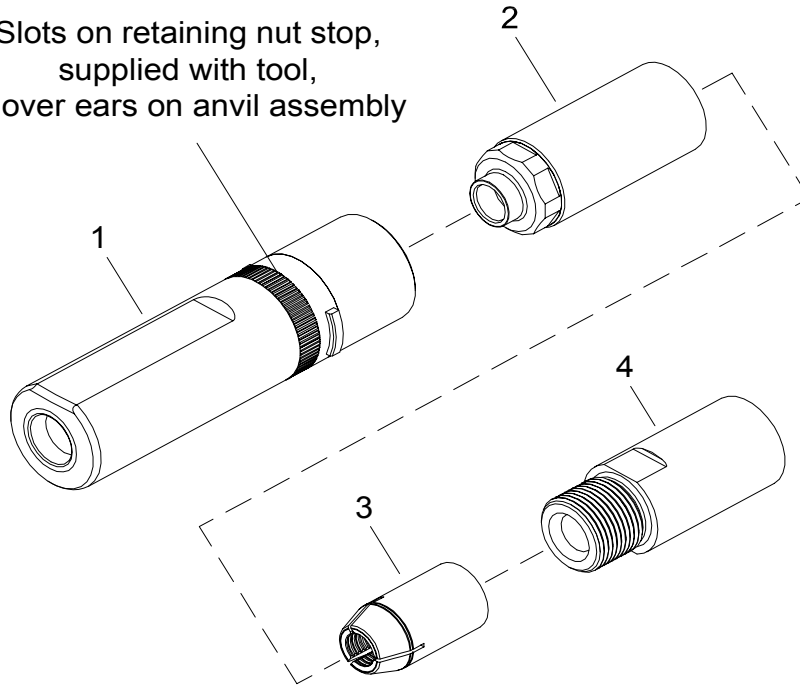

Rev. 12/06



\*Anvil Assembly includes 35308 retainer.  
\*\*GB745 not recommended for C120L lockbolts.

**GAGE BILT**  
MADE IN U.S.A.

**GAGE BILT Inc.**

44766 Centre Court (586) 226-1500  
Clinton Twp. MI 48038 (586) 226-1505 Fax  
e-mail:solutions@gagebilt.com / www.gagebilt.com

Type:		Fasteners:	Recommended Tools: **GB745
Non Self-Releasing 3/8 Ø		Commercial Lockbolt	Alternate Tools: GBP4801B & GBP4804
Ref. No.	Qty.	Description	LB12-756-26
1	1	Anvil	11202
2	1	Collet	21224
3	1	Super-Grip Jaw Assembly	31226-S
4	1	Collet Extension	71219