

NOSE ASSEMBLY DATA SHEET

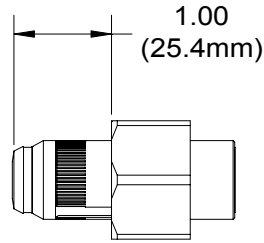

Use Hex-Key in rear of piston for nose assembly attachment.

A 05-.635 (16.1mm)
06-.705 (17.9mm)
08-.750 (19.1mm)

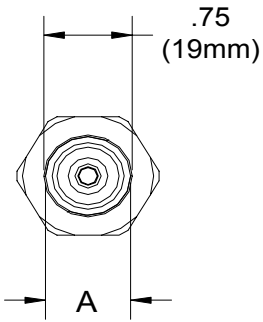
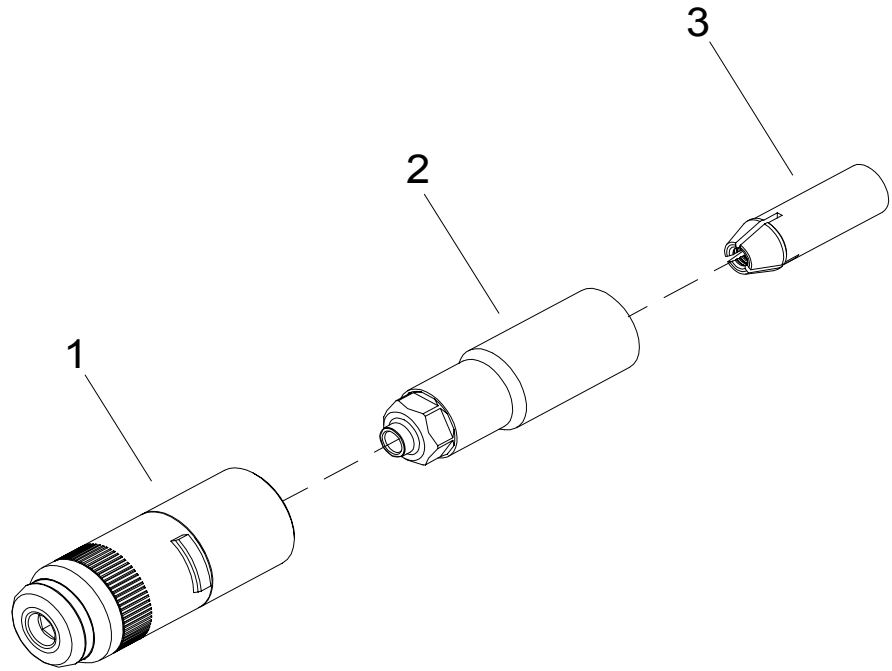

6/02

*Anvil Assembly includes 35208 retainer.

GAGE BILT

GAGE BILT Inc.

44766 Centre Court (586) 226-1500
Clinton Twp., MI 48038 (586) 226-1505 Fax
e-mail:solutions@gagebilt.com / www.gagebilt.com

Type:		Fastener:		Recommended Tool: GBP730E	
5/32, 3/16 & 1/4 Ø		LGP® Lockbolts		Alternate Tools: GBP713D & GBP2480	
Ref. No.	Qty.	Description	LGP05-730B-10	LGP06-730B-10	LGP08-730B-10
1	1	Anvil Assembly	10590	16621	18816
2	1	Collet	20540	20660	20877
3	1	Super Grip Jaw Assembly	30542-S2	30651-S2	30858-S2