

NOSE ASSEMBLY DATA SHEET

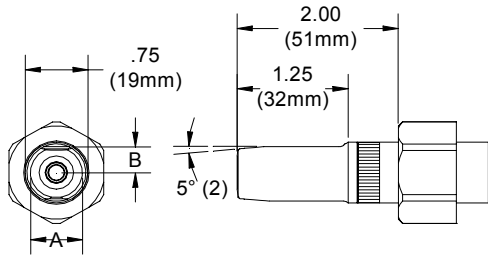

Use Hex-Key in rear of piston for nose assembly attachment.

Use Hex-Key in rear of collet-extension for collet disassembly.

A 05-.635 (16.1mm)
06-.705 (17.9mm)
08-.750 (19.1mm)

B 05-.290 (7.4mm)
06-.320 (8.1mm)
08-.350 (8.9mm)

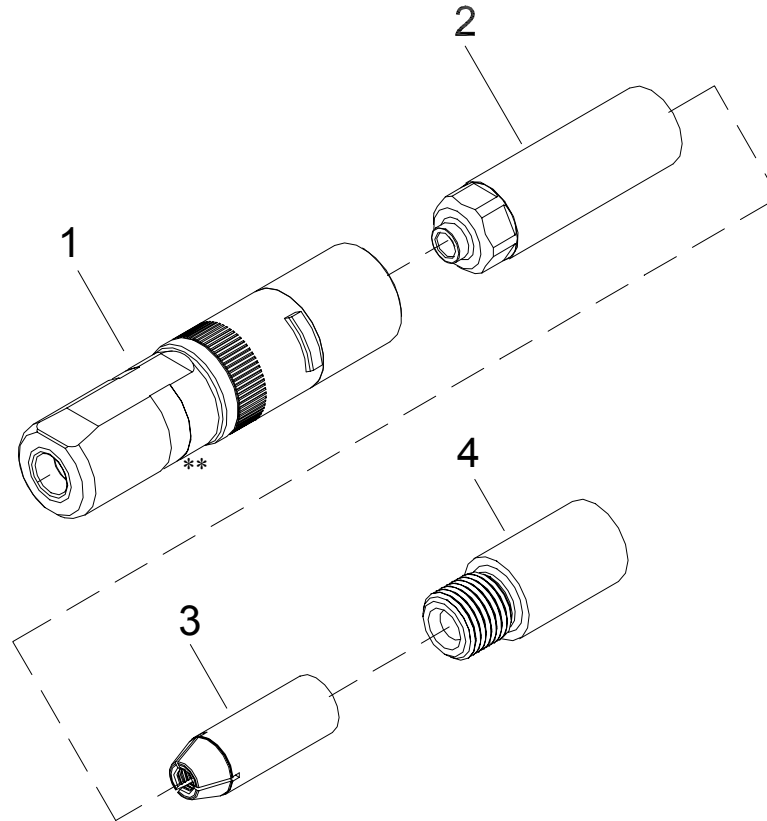

*Anvil Assembly includes 35208 retainer.

**Yellow band designates nose assemblies for liehtwiegtht GP® fasteners.

4/00

GAGE BILT

GAGE BILT PRODUCTS CORP.

14500 Barber Drive (586) 771-7664
Warren, Mi 48088 (586) 771-2665 Fax
e-mail:solutions@gagebilt.com / www.gagebilt.com

Type:
Non Self-Releasing
Chisel Nose
5/32, 3/16 & 1/4 Ø

Fastener:

LGP® Lockbolts

Recommended Tool:
GBP730B
Alternate Tools:
GBP712 & GBP2400

| Ref. No. | Qty. | Description | LGP05-730B-20CN | LGP06-730B-20CN | LGP08-730B-20CN |
|----------|------|-------------------------|-----------------|-----------------|-----------------|
| 1 | 1 | Anvil Assembly | 10572 | 16610 | 18807 |
| 2 | 1 | Collet | 20537 | 20655 | 20869 |
| 3 | 1 | Super Grip Jaw Assembly | 30542-S | 30651-S | 30858-S |
| 4 | 1 | Collet Extension | 70550 | 70636 | 70835 |

LGP® is a registered trademark of Huck Int'l. Inc.