

# NOSE ASSEMBLY DATA SHEET

Use Hex-Key in rear of piston for nose assembly attachment.

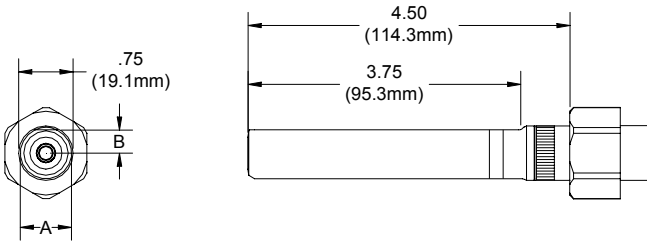

A 05-.635 (16.1mm)  
06-.705 (17.9mm)  
08-.750 (19.1mm)

B 05-.290 (7.4mm)  
06-.320 (8.1mm)  
08-.350 (8.9mm)

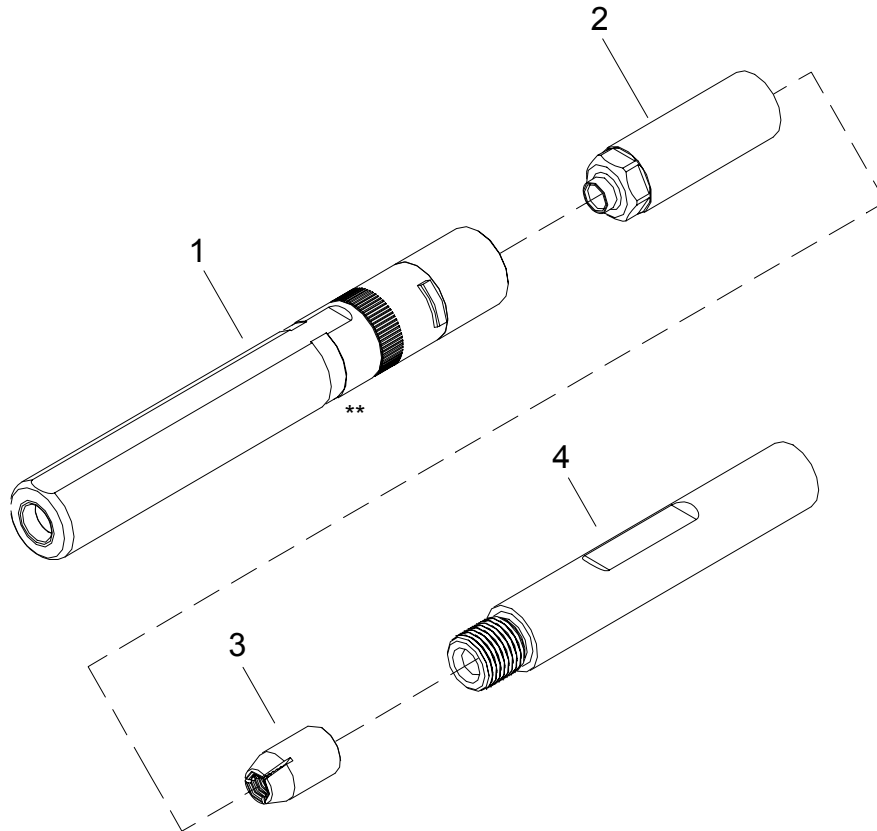

4/00

\*Anvil Assembly includes 35208 retainer.  
\*\*Yellow band designates nose assemblies for lightweight GP® fasteners.

## GAGE BILT

### GAGE BILT PRODUCTS CORP.

14500 Barber Drive (586) 771-7664  
Warren, Mi 48088 (586) 771-2665 Fax  
e-mail:solutions@gagebilt.com / www.gagebilt.com

Type: Non Self-Releasing		Fastener:		Recommended Tool: GBP730B	
5/32, 3/16 & 1/4 Ø		LGP® Lockbolts		Alternate Tools: GBP712 & GBP2400	
Ref. No.	Qty.	Description	LGP05-730B-45	LGP06-730B-45	LGP08-730B-45
1	1	Anvil Assembly	10567	16604	10889
2	1	Collet	20537	20655	20869
3	1	Super Grip Jaw Assembly	30542-S	30651-S	30858-S
4	1	Collet Extension	70551	70637	70834

LGP® is a registered trademark of Huck Int'l. Inc.