

# NOSE ASSEMBLY DATA SHEET

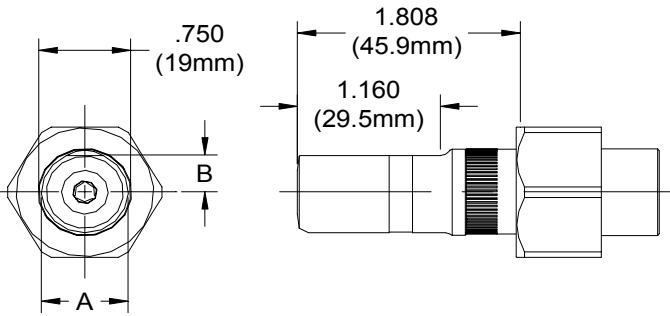

A 05-.635 (16.1mm)  
06-.705 (17.9mm)  
08-.750 (19.0mm)

B 05-.290 (7.4mm)  
06-.320 (8.1mm)  
08-.350 (8.9mm)

1. Drop jaws #3 and spacer #4 (if needed) into collet #2.
2. Snug extension #5 and collet #2 together using wrench on collet #2 and hex key in rear of extension #5.
3. Thread assembly onto piston and snug with wrench on collet #2 and hex key (provided with tool) into rear of piston.
4. Slide anvil #1 over assembled collet #2 and extension #6.
5. Slide retaining nut stop and nut from tool over anvil #1 and tighten.

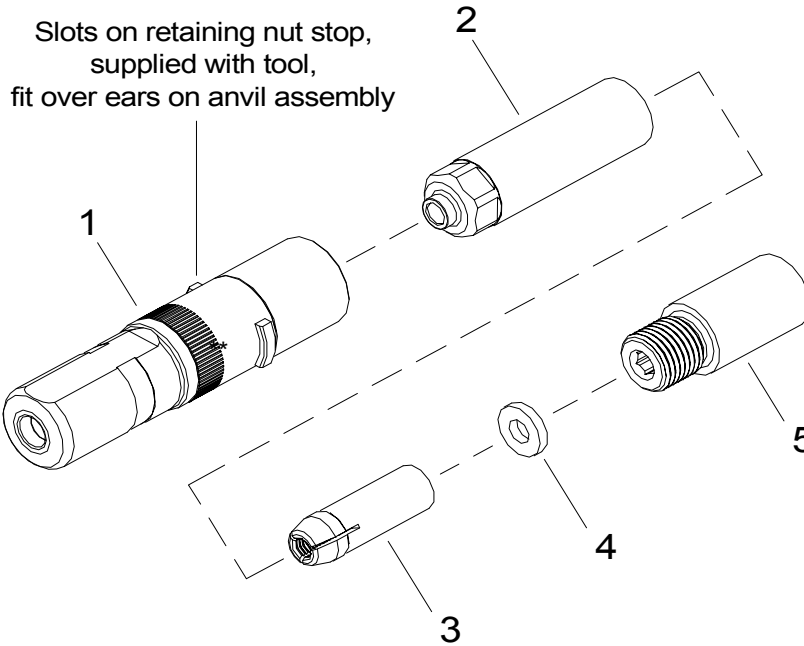

\*Anvil Assembly includes 35208 retainer.

\*\*Yellow band designates nose assemblies for lightweight GP® fasteners.

Rev. 8/09

## GAGE BILT

### GAGE BILT Inc.

44766 Centre Court (586) 226-1500  
Clinton Twp., MI 48038 (586) 226-1505 Fax  
e-mail:solutions@gagebilt.com / www.gagebilt.com

Type:		Fasteners:		Recommended Tool:	
Non Self-Releasing 5/32, 3/16 & 1/4 Ø		LGP® Lockbolts		GB731	
				Alternate Tools: GB730 & GB2480	
Ref. No.	Qty.	Description	LGP05-731-20	LGP06-731-20	LGP08-731-20
1	1	Anvil	10566	16602	10891
2	1	Collet	20584	26606	28825
3	1	Super-Grip Jaw Assembly	30543-S	30654-S	30861-S1
4	1	Spacer	----	60615	60832
5	1	Collet Extension	70550	70636	70835