

# NOSE ASSEMBLY DATA SHEET

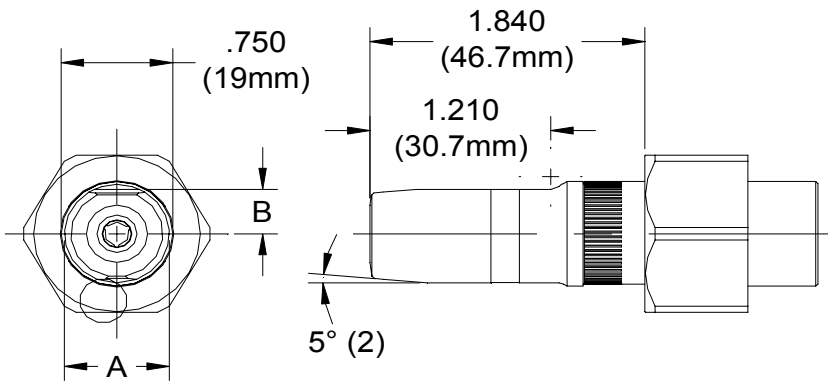

Use Hex-Key in rear of piston for nose assembly attachment.

Use Hex-Key in rear of collet extension for collet disassembly.

A 05-.635 (16.1mm)  
06-.705 (17.9mm)  
08-.749 (19.0mm)

B 05-.290 (7.4mm)  
06-.320 (8.1mm)  
08-.350 (8.9mm)

Slots on retaining nut stop, supplied with tool, fit over ears on anvil assembly

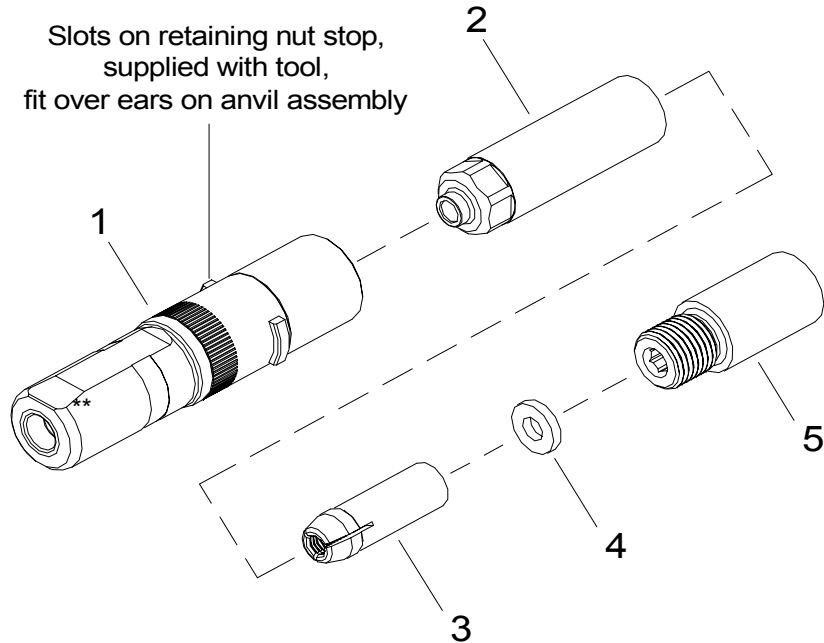

\*Anvil Assembly includes 35208 retainer.

\*\*Yellow band designates nose assemblies for lightweight GP® fasteners.

5/05 REV. 3/12

## GAGE BILT

### GAGE BILT Inc.

44766 Centre Court (586) 226-1500  
Clinton Twp., MI 48038 (586) 226-1505 Fax  
e-mail:solutions@gagebilt.com / www.gagebilt.com

Type:		Fasteners:		Recommended Tool: GB731	
Non Self-Releasing 5/32, 3/16 & 1/4 Ø		LGP® Lockbolts		Alternate Tool: GB2480	
Ref. No.	Qty.	Description	LGP05-731-20CN	LGP06-731-20CN	LGP08-731-20CN
1	1	Anvil	10572	16610	18807
2	1	Collet	20584	26606	28825
3	1	Super-Grip Jaw Assembly	30543-S	30654-S	30861-S1
4	1	Spacer	----	60615	60832
5	1	Collet Extension	70550	70636	70835