

NOSE ASSEMBLY DATA SHEET

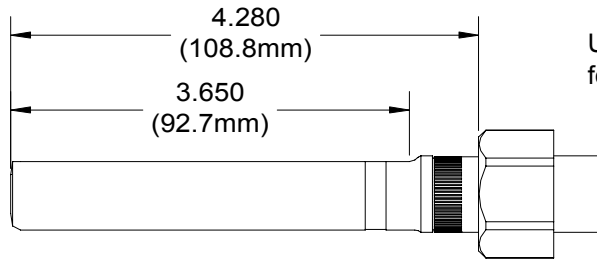
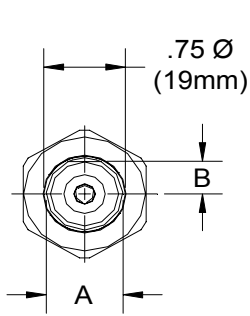

Use Hex-Key in rear of piston for nose assembly attachment.

A 05-.635 (16.1mm)
06-.705 (17.9mm)
08-.750 (19.0mm)

B 05-.290 (7.4mm)
06-.320 (8.1mm)
08-.350 (8.9mm)

Slots on retaining nut stop, supplied with tool, fit over ears on anvil assembly

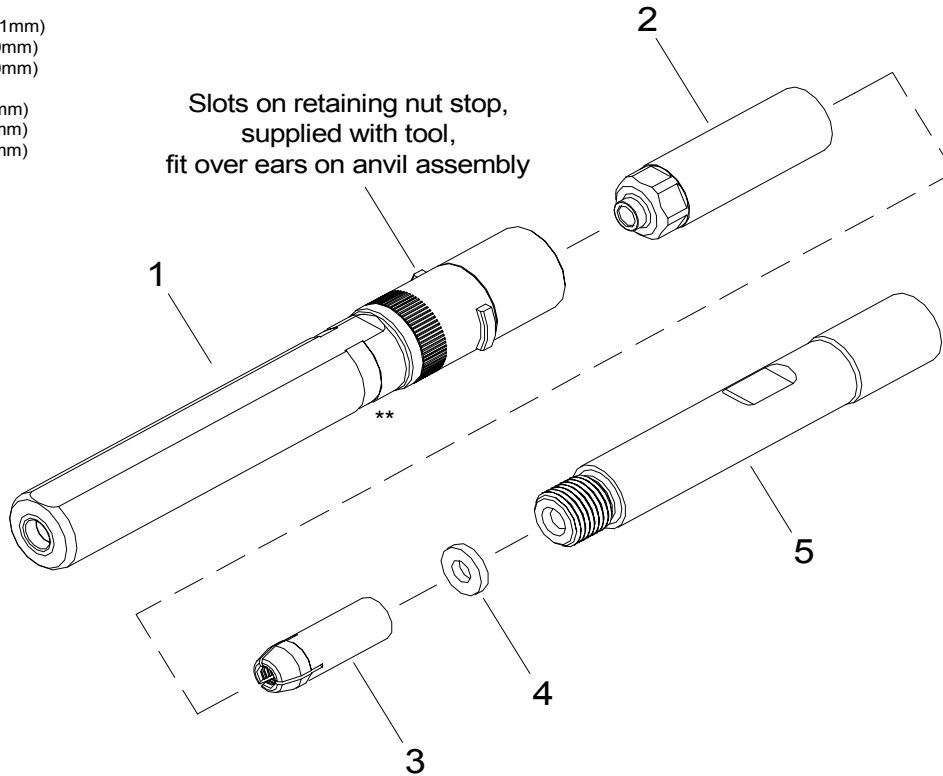

*Anvil Assembly includes 35208 retainer.

**Yellow band designates nose assemblies for lightweight GP® fasteners.

5/05 REV. 3/11

GAGE BILT

GAGE BILT Inc.

44766 Centre Court (586) 226-1500
Clinton Twp, MI 48038 (586) 226-1505 Fax
e-mail:solutions@gagebilt.com / www.gagebilt.com

Type:		Fasteners:		Recommended Tool:	
Non Self-Releasing 5/32 & 3/16 Ø		LGP® Lockbolts		GB731	
				Alternate Tools: GB730 & GB2480	
Ref. No.	Qty.	Description	LGP05-731-45	LGP06-731-45	LGP08-731-45
1	1	Anvil	10567	16604	10889
2	1	Collet	20584	26606	28825
3	1	Super-Grip Jaw Assembly	30543-S	30654-S	30861-S1
4	1	Spacer	----	60615	60832
5	1	Collet Extension	70551	70637	70834