

NOSE ASSEMBLY DATA SHEET

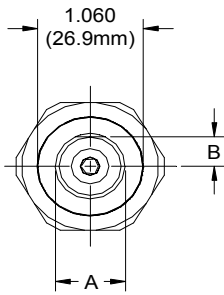

- A 05-.635 (16.1mm)
 06-.705 (17.9mm)
 08-.750 (19.1mm)
- B 05-.290 (7.4mm)
 06-.320 (8.1mm)
 08-.350 (10.9mm)

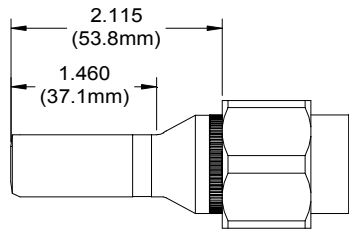

Use Hex-Key in rear of piston for nose assembly attachment.

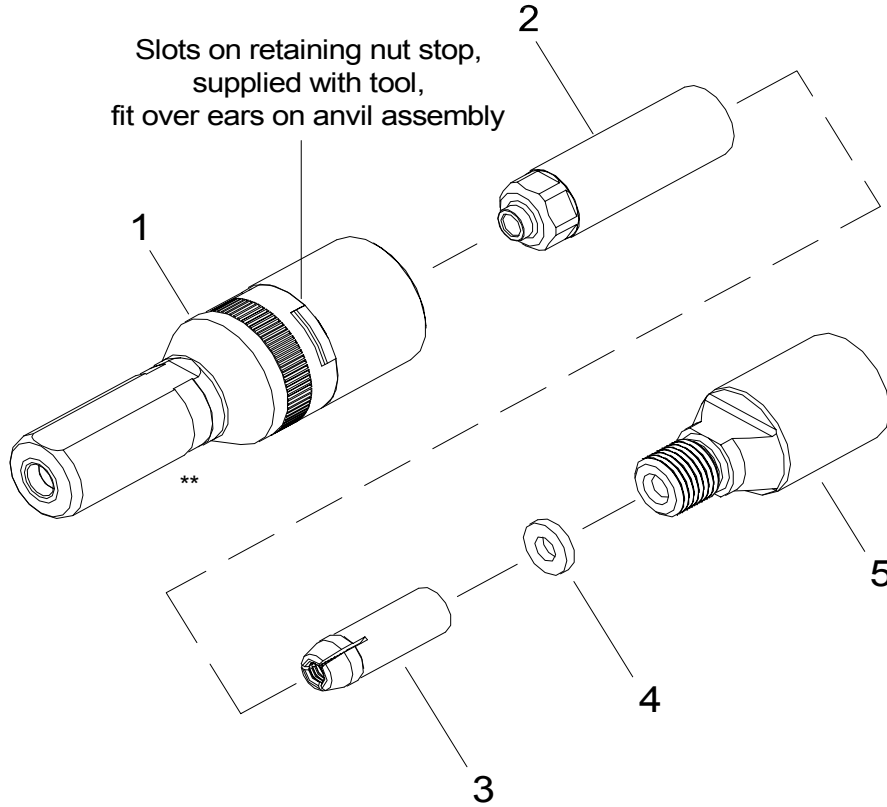

*Anvil Assembly includes 35308 retainer.

**Yellow band designates nose assemblies for lightweight GP® fasteners.

Rev. 2/09

GAGE BILT

GAGE BILT Inc.

44766 Centre Court (586) 226-1500
 Clinton Twp., MI 48038 (586) 226-1505 Fax
 e-mail:solutions@gagebilt.com / www.gagebilt.com

Type:		Fasteners:		Recommended Tool: GB745	
Non Self-Releasing 5/32 & 3/16 Ø		LGP® lockbolts		Alternate Tools: GBP4801B	
Ref. No.	Qty.	Description	LGP05-755-23	LGP06-755-23	LGP08-755-23
1	1	Anvil	10569	16612	10892
2	1	Collet	20584	26606	28825
3	1	Super-Grip Jaw Assembly	30543-S	30654-S	30861-S1
4	1	Spacer	----	60615	60832
5	1	Collet Extension	70552	70635	70836