

# NOSE ASSEMBLY DATA SHEET

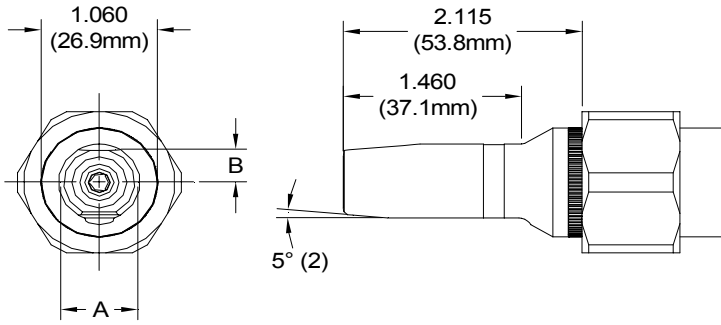

Use Hex-Key in rear of piston for nose assembly attachment.

- A 05-.635 (16.1mm)  
06-.705 (17.9mm)
- B 05-.290 (7.4mm)  
06-.320 (8.1mm)

Slots on retaining nut stop, supplied with tool, fit over ears on anvil assembly

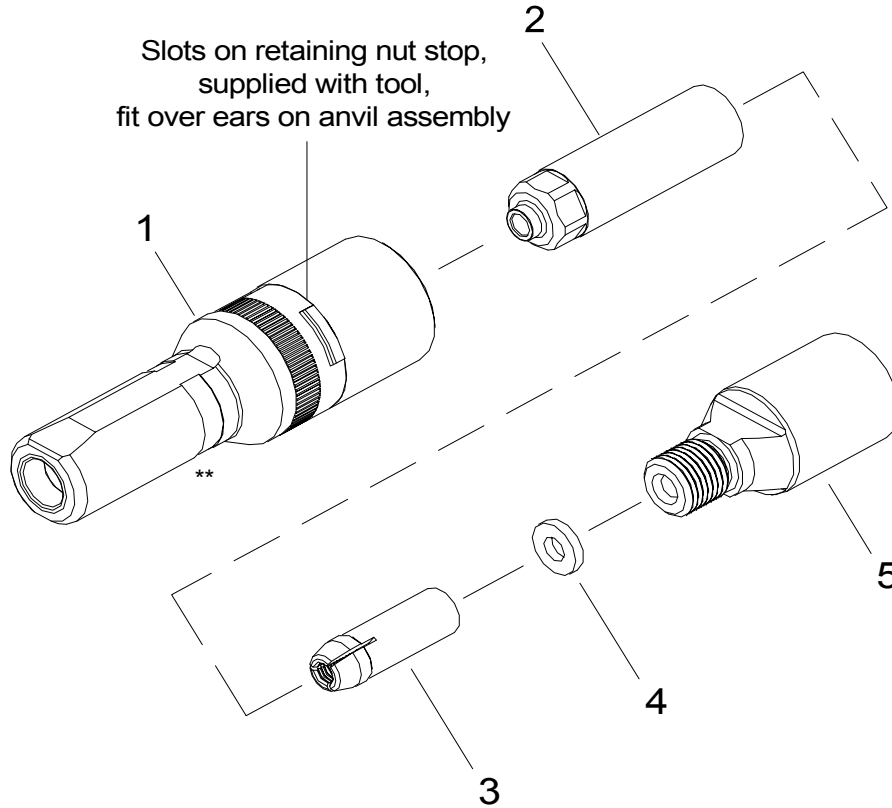

\*Anvil Assembly includes 35308 retainer.

\*\*Yellow band designates nose assemblies for lightweight GP® fasteners.

5/05

## GAGE BILT

### GAGE BILT Inc.

44766 Centre Court (586) 226-1500  
Clinton Twp., MI 48038 (586) 226-1505 Fax  
e-mail:solutions@gagebilt.com / www.gagebilt.com

Type:		Fasteners:	Recommended Tool: GB745	
Non Self-Releasing 5/32 & 3/16 Ø		LGP® lockbolts	Alternate Tools: GBP4801B	
Ref. No.	Qty.	Description	LGP05-755-23CN	LGP06-755-23CN
1	1	Anvil	10582	16616
2	1	Collet	20584	26606
3	1	Super-Grip Jaw Assembly	30543-S	30654-S
4	1	Spacer	----	60615
5	1	Collet Extension	70552	70635