

NOSE ASSEMBLY DATA SHEET

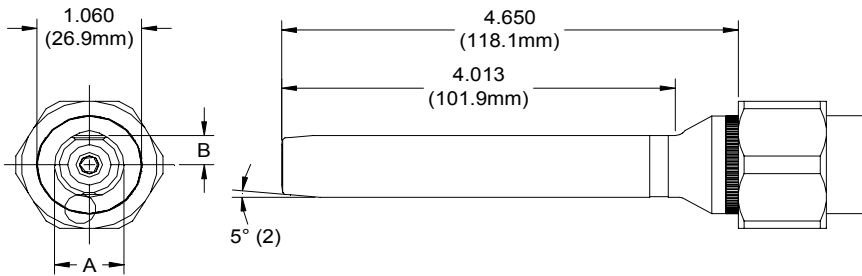

Use Hex-Key in rear of piston for nose assembly attachment.

A 05-.635 (16.1mm)
06-.705 (17.9mm)
08-.812 (20.6mm)

B 05-.290 (7.4mm)
06-.320 (8.1mm)
08-.350 (8.9mm)

Slots on retaining nut stop, supplied with tool, fit over ears on anvil assembly

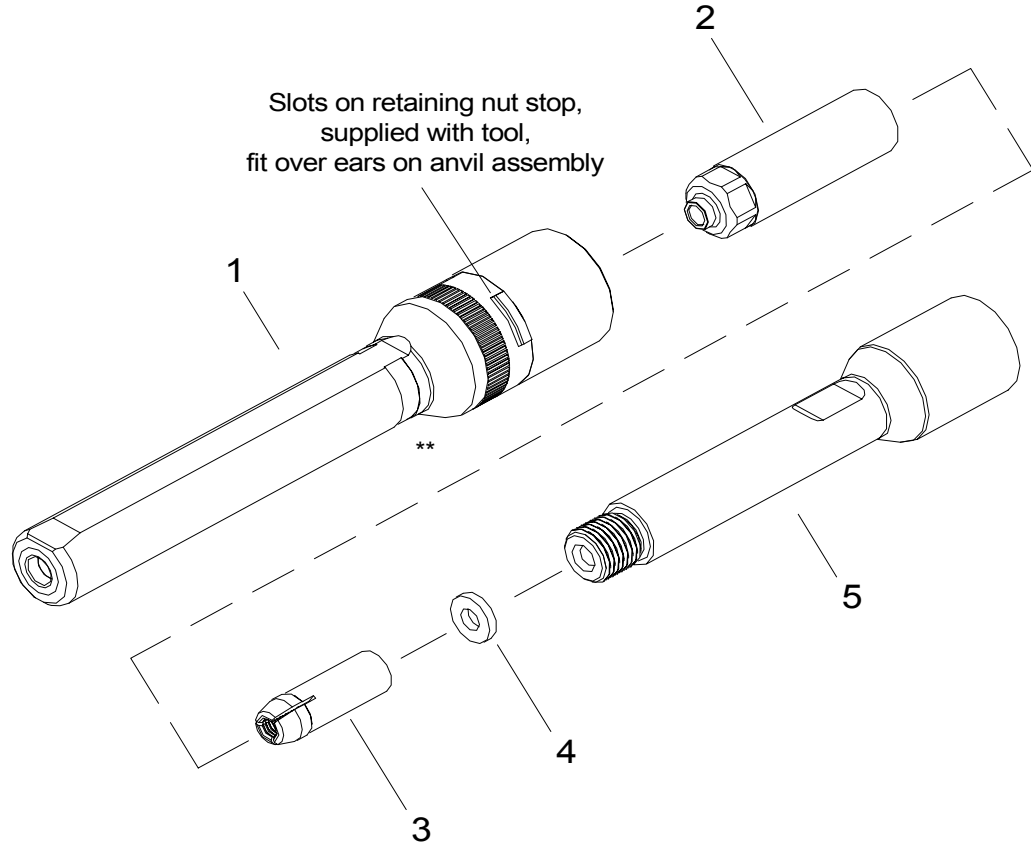

*Anvil Assembly includes 35308 retainer.

5/05 Rev. 3/11

**Yellow band designates nose assemblies for lightweight GP® fasteners.

GAGE BILT

GAGE BILT Inc.

44766 Centre Court (586) 226-1500
Clinton Twp., MI 48038 (586) 226-1505 Fax
e-mail:solutions@gagebilt.com / www.gagebilt.com

Type:		Fasteners:		Recommended Tool: GB745	
Non Self-Releasing 5/32, 3/16 & 1/4 Ø		LGP® lockbolts		Alternate Tools: GB756 & GBP4801B	
Ref. No.	Qty.	Description	LGP05-755-48CN	LGP06-755-48CN	LGP08-755-48CN
1	1	Anvil	10583	16617	18814
2	1	Collet	20584	26606	28825
3	1	Super-Grip Jaw Assembly	30543-S	30654-S	30861-S1
4	1	Spacer	----	60615	60832
5	1	Collet Extension	70553	70638	70837